

FOREWORD

This wiring diagram manual has been prepared to provide information on the electrical system of the 2007 FJ CRUISER.

Applicable models: GSJ10, 15 Series

Refer to the following manuals for additional service specifications and repair procedures for these models:

Manual Name	Pub. No.
● 2007 FJ CRUISER Repair Manual	RM0240U
● 2007 FJ CRUISER New Car Features	NM0240U

All information in this manual is based on the latest product information at the time of publication. However, specifications and procedures are subject to change without notice.

TOYOTA MOTOR CORPORATION

NOTICE

Always follow the directions given in the above repair manuals when handling supplemental restraint system components (such as removal, installation, inspection, etc.) in order to prevent accidents and supplemental restraint system malfunction.

©2006 TOYOTA MOTOR CORPORATION

All rights reserved. This book may not be reproduced or copied, in whole or in part, without the written permission of Toyota Motor Corporation.

First Printing : Jan. 13, 2006 01-060113-00

2007 FJ CRUISER ELECTRICAL WIRING DIAGRAM

	Section Code	Page
INTRODUCTION	A	2
HOW TO USE THIS MANUAL	B	3
TROUBLESHOOTING	C	12
ABBREVIATIONS	D	17
GLOSSARY OF TERMS AND SYMBOLS	E	18
RELAY LOCATIONS	F	20
ELECTRICAL WIRING ROUTING	G	38
SYSTEM CIRCUITS	H	55
GROUND POINT	I	256
POWER SOURCE (Current Flow Chart)	J	264
CONNECTOR LIST	K	270
PART NUMBER OF CONNECTORS	L	286
OVERALL ELECTRICAL WIRING DIAGRAM .	M	290

A INTRODUCTION

This manual consists of the following 13 sections:

No.	Section	Description
A	INDEX	Index of the contents of this manual.
	INTRODUCTION	Brief explanation of each section.
B	HOW TO USE THIS MANUAL	Instructions on how to use this manual.
C	TROUBLE-SHOOTING	Describes the basic inspection procedures for electrical circuits.
D	ABBREVIATIONS	Defines the abbreviations used in this manual.
E	GLOSSARY OF TERMS AND SYMBOLS	Defines the symbols and functions of major parts.
F	RELAY LOCATIONS	Shows position of the Electronic Control Unit, Relays, Relay Block, etc. This section is closely related to the system circuit.
G	ELECTRICAL WIRING ROUTING	Describes position of Parts Connectors, Splice points, Ground points, etc. This section is closely related to the system circuit.
H	INDEX	Index of the system circuits.
	SYSTEM CIRCUITS	Electrical circuits of each system are shown from the power supply through ground points. Wiring connections and their positions are shown and classified by code according to the connection method. (Refer to the section, "How to use this manual"). The "System Outline" and "Service Hints" useful for troubleshooting are also contained in this section.
I	GROUND POINT	Shows ground positions of all parts described in this manual.
J	POWER SOURCE (Current Flow Chart)	Describes power distribution from the power supply to various electrical loads.
K	CONNECTOR LIST	Describes the form of the connectors for the parts appeared in this book. This section is closely related to the system circuit.
L	PART NUMBER OF CONNECTORS	Indicates the part number of the connectors used in this manual.
M	OVERALL ELECTRICAL WIRING DIAGRAM	Provides circuit diagrams showing the circuit connections.

This manual provides information on the electrical circuits installed on vehicles by dividing them into a circuit for each system.

The actual wiring of each system circuit is shown from the point where the power source is received from the battery as far as each ground point. (All circuit diagrams are shown with the switches in the OFF position.)

When troubleshooting any problem, first understand the operation of the circuit where the problem was detected (see System Circuit section), the power source supplying power to that circuit (see Power Source section), and the ground points (see Ground Point section). See the System Outline to understand the circuit operation.

When the circuit operation is understood, begin troubleshooting of the problem circuit to isolate the cause. Use Relay Location and Electrical Wiring Routing sections to find each part, junction block and wiring harness connectors, wiring harness and wiring harness connectors and ground points of each system circuit. Internal wiring for each junction block is also provided for better understanding of connection within a junction block.

Wiring related to each system is indicated in each system circuit by arrows (from__, to__). When overall connections are required, see the Overall Electrical Wiring Diagram at the end of this manual.

B HOW TO USE THIS MANUAL

* The system shown here is an EXAMPLE ONLY. It is different to the actual circuit shown in the SYSTEM CIRCUITS SECTION.

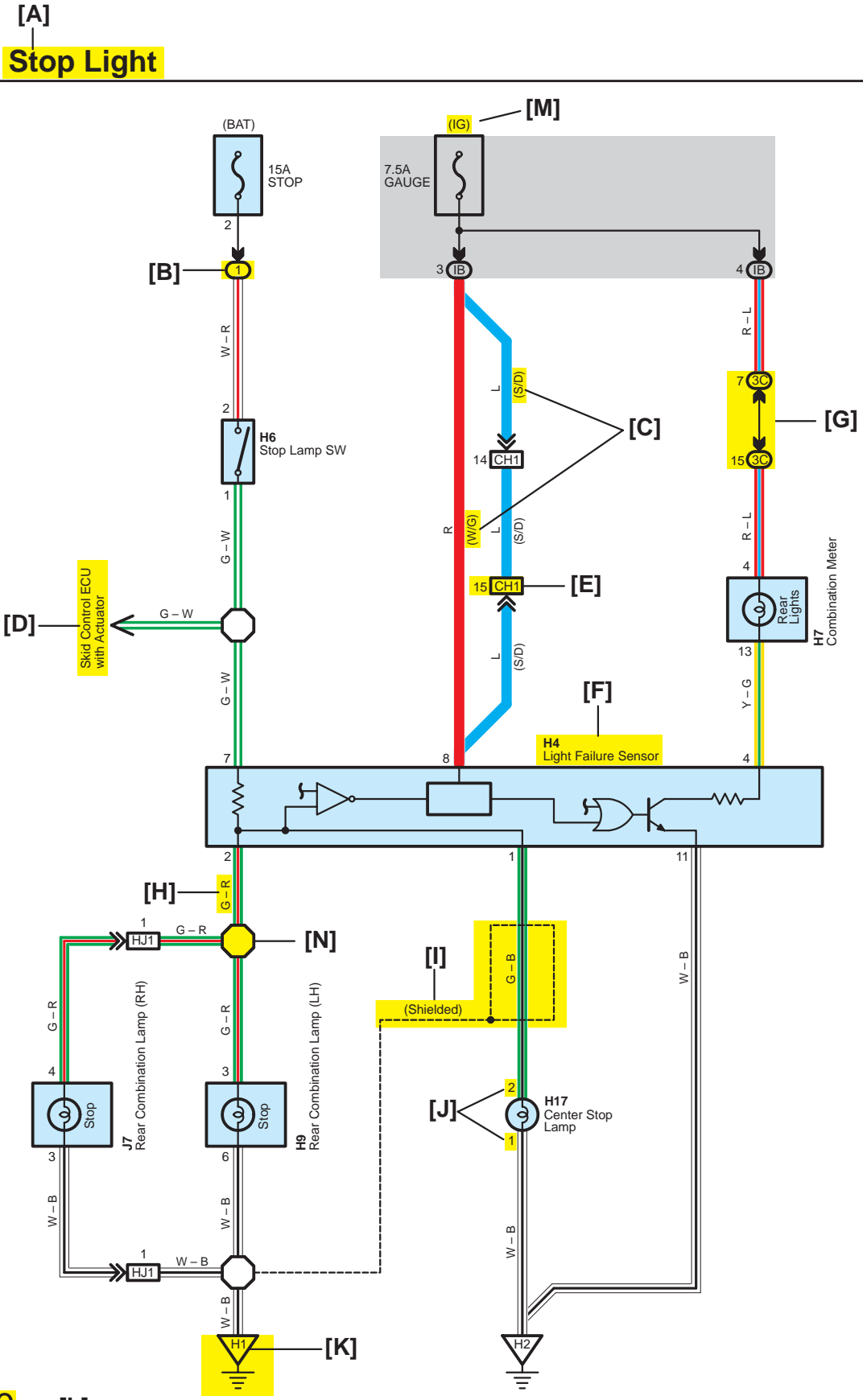

[A] : System Title

[B] : Indicates a Relay Block. No shading is used and only the Relay Block No. is shown to distinguish it from the J/B

Example: ① Indicates Relay Block No.1

[C] : () is used to indicate different wiring and connector, etc. when the vehicle model, engine type, or specification is different.

[D] : Indicates related system.

[E] : Indicates the code for the (male and female) connectors which are used to join two wire harnesses. The connector code consists of two alphabetical and one numerical characters.

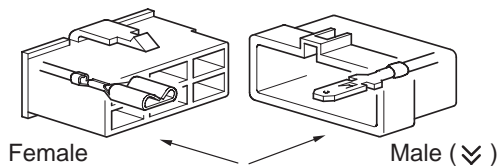

The first character of the connector code indicates the alphabetical code allocated to the wire harness which has the female connector, and the second shows that of the wire harness which has the male connector.

The third character indicates a serial number used to distinguish between the wire harness combinations in cases when more than one of the same combination of wire harnesses exist (e.g. CH1 and CH2).

Symbol (∨) indicates the male terminal connector. Numbers outside connector codes indicate the pin numbers of both male and female connectors.

[F] : Represents a part (all parts are shown in sky blue). The code is the same as the code used in parts position.

[G] : Junction Block (The number in the circle is the J/B No. and the connector code is shown beside it). Junction Blocks are shaded to clearly separate them from other parts.

Example:

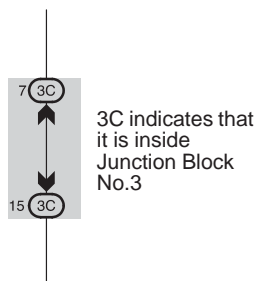

[H] : Indicates the wiring color.

Wire colors are indicated by an alphabetical code.

- B = Black W = White BR = Brown
- L = Blue V = Violet SB = Sky Blue
- R = Red G = Green LG = Light Green
- P = Pink Y = Yellow GR = Gray
- O = Orange

The first letter indicates the basic wire color and the second letter indicates the color of the stripe.

Example: L - Y

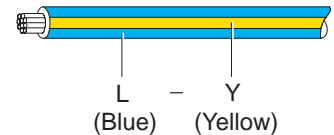

[I] : Indicates a shielded cable.



[J] : Indicates the pin number of the connector. The numbering system is different for female and male connectors.

Example: Numbered in other from upper left to lower right

Numbered in other from upper right to lower left

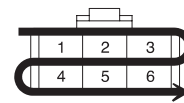

Female

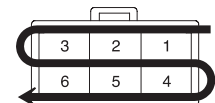

Male

[K] : Indicates the ground point. The code consists of the two characters: A letter and number.

The first character of the code indicates the alphabetical code allocated to the wire harness. The second character indicates a serial number used to distinguish between the ground points in cases when more than one ground point exist on the same wire harness.

[L] : Page No.

[M] : Indicates the ignition key position(s) when the power is supplied to the fuse(s).

[N] : Indicates a wiring Splice Point.

Example:

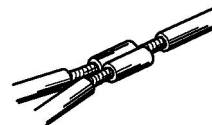

B HOW TO USE THIS MANUAL

[O] System Outline

Current is applied at all times through the STOP fuse to TERMINAL 2 of the stop lamp SW.
When the ignition SW is turned on, current flows from the GAUGE fuse to TERMINAL 8 of the light failure sensor, and also flows through the rear lights warning light to TERMINAL 4 of the light failure sensor.

Stop Light Disconnection Warning

When the ignition SW is turned on and the brake pedal is pressed (Stop lamp SW on), if the stop light circuit is open, the current flowing from TERMINAL 7 of the light failure sensor to TERMINALS 1, 2 changes, so the light failure sensor detects the disconnection and the warning circuit of the light failure sensor is activated.

As a result, the current flows from TERMINAL 4 of the light failure sensor to TERMINAL 11 to GROUND and turns the rear lights warning light on. By pressing the brake pedal, the current flowing to TERMINAL 8 of the light failure sensor keeps the warning circuit on and holds the warning light on until the ignition SW is turned off.

[P] ○ : Parts Location

Code	See Page	Code	See Page	Code	See Page
H4	36	H7	36	H17	38
H6	36	H9	38	J7	38

[Q] ○ : Relay Blocks

Code	See Page	Relay Blocks (Relay Block Location)
1	18	R/B No.1 (Instrument Panel Brace LH)

[R] ○ : Junction Block and Wire Harness Connector

Code	See Page	Junction Block and Wire Harness (Connector Location)
3C	22	Instrument Panel Wire and J/B No.3 (Instrument Panel Brace LH)
IB	20	Instrument Panel Wire and Instrument Panel J/B (Lower Finish Panel)

[S] □ : Connector Joining Wire Harness and Wire Harness

Code	See Page	Joining Wire Harness and Wire Harness (Connector Location)
CH1	42	Engine Room Main Wire and Instrument Panel Wire (Left Kick Panel)
HJ1	50	Instrument Panel Wire and Floor Wire (Right Kick Panel)

[T] ▽ : Ground Points

Code	See Page	Ground Points Location
H1	50	Under the Left Center Pillar
H2	50	Back Panel Center

[O] : Explains the system outline.

[P] : Indicates reference pages showing the parts locations in the system circuit on the vehicle.

Example : Code "H4" (Light Failure Sensor) is on page 36 of the manual.

* The first character of the code indicates the alphabetical code allocated to the wire harness, and the second character indicates the serial number of the parts connected to the wire harness.

Example : H 4
 └──┬── Serial number for the connected parts
 └── Code for the wire harness

[Q] : Indicates the reference page showing the position on the vehicle of Relay Block Connectors in the system circuit.

Example : Connector "1" is described on page 18 of this manual and is installed on the left side of the instrument panel.

[R] : Indicates the reference page showing the position on the vehicle of J/B and Wire Harness in the system circuit.

Example : Connector "3C" connects the Instrument Panel Wire and J/B No.3. It is described on page 22 of this manual, and is installed on the instrument panel left side.

[S] : Indicates the reference page describing the wiring harness and wiring harness connector (the female wiring harness is shown first, followed by the male wiring harness).

Example : Connector "CH1" connects the Engine Room Main Wire (female) and Instrument Panel Wire (male). It is described on page 42 of this manual, and is installed on the left side kick panel.

[T] : Indicates the reference page showing the position of the ground points on the vehicle.

Example : Ground point "H2" is described on page 50 of this manual and is installed on the back panel center.

B HOW TO USE THIS MANUAL

The ground points circuit diagram shows the connections from all major parts to the respective ground points. When troubleshooting a faulty ground point, checking the system circuits which use a common ground may help you identify the problem ground quickly. The relationship between ground points ($\nabla A1$, $\nabla A2$ and $\nabla D4$ shown below) can also be checked this way.

I GROUND POINT

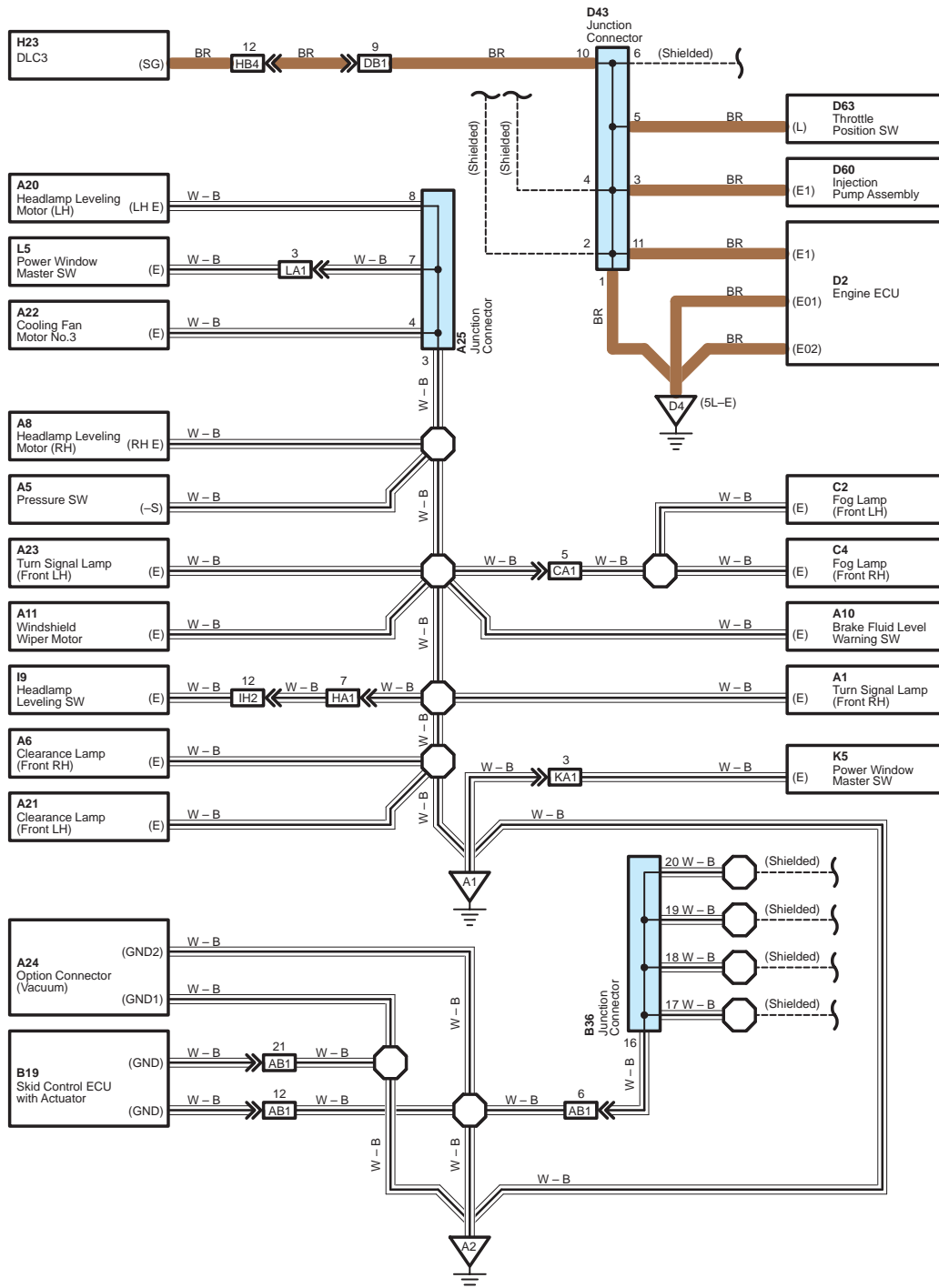

* The system shown here is an EXAMPLE ONLY. It is different to the actual circuit shown in the SYSTEM CIRCUITS SECTION.

The "Current Flow Chart" section, describes which parts each power source (fuses, fusible links, and circuit breakers) transmits current to. In the Power Source circuit diagram, the conditions when battery power is supplied to each system are explained. Since all System Circuit diagrams start from the power source, the power source system must be fully understood.

J POWER SOURCE (Current Flow Chart)

The chart below shows the route by which current flows from the battery to each electrical source (Fusible Link, Circuit Breaker, Fuses, etc.) and other parts

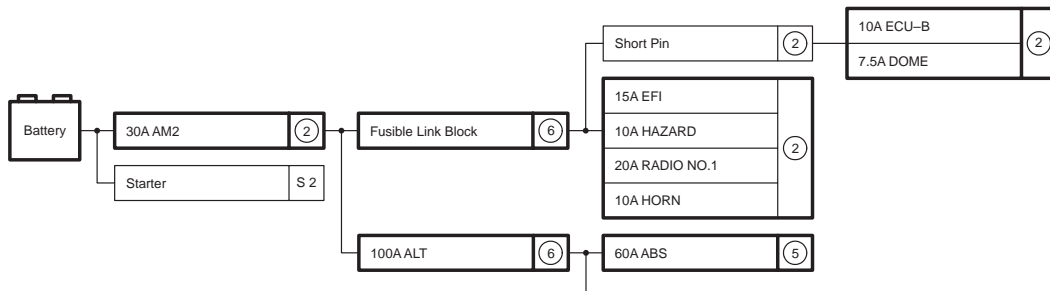

Engine Room R/B (See Page 20)

Fuse	System	Page
20A STOP	ABS	194
	ABS and Traction Control	187
	Cruise Control	180
	Electronically Controlled Transmission	166
	Multiplex Communication System	210
10A DOME	Cigarette Lighter	214
	Combination Meter	230
	Headlight	112
	Interior Light	122
	Key Reminder and Seat Belt Warning	
	Light Auto Turn Off System	

Power Source

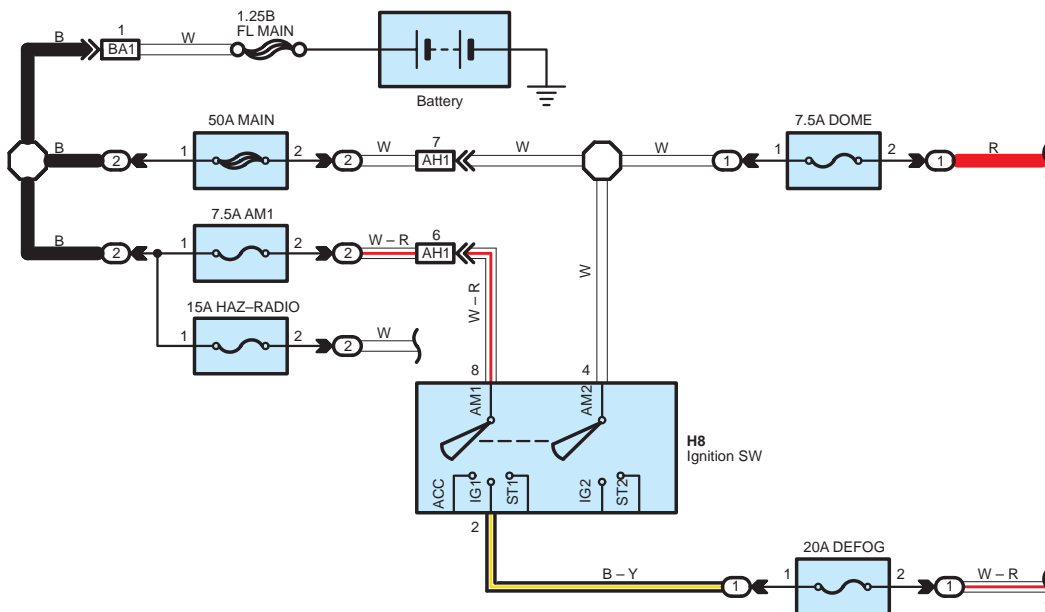

* The system shown here is an EXAMPLE ONLY. It is different to the actual circuit shown in the SYSTEM CIRCUITS SECTION.

B HOW TO USE THIS MANUAL

K CONNECTOR LIST

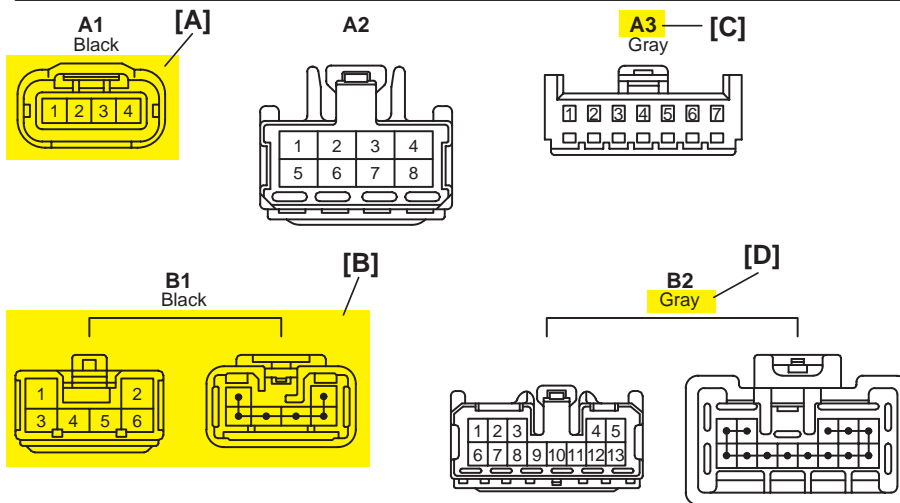

K CONNECTOR LIST

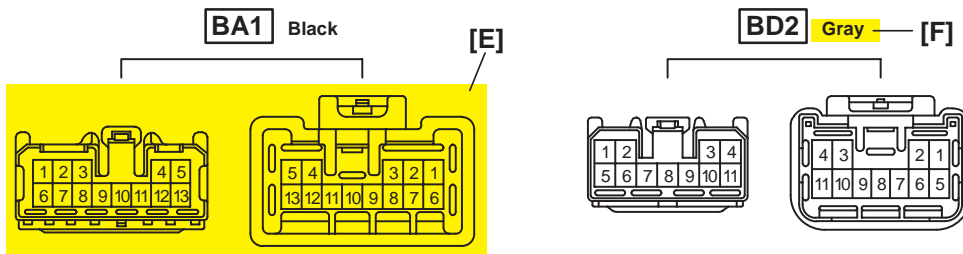

[A] : Indicates connector to be connected to a part. (The numeral indicates the pin No.)

[B] : Junction Connector
Indicates a connector which is connected to a short terminal.

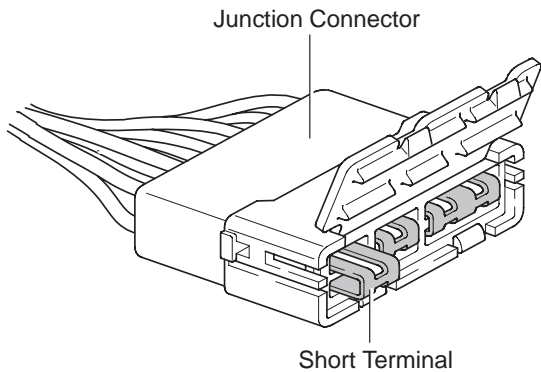

Junction connector in this manual include a short terminal which is connected to a number of wire harnesses. Always perform inspection with the short terminal installed.

[C] : Parts Code
The first letter of the code is taken from the first letter of part, and the numbers indicates its order in parts which start with the same letter.

[D] : Connector Color
Connectors not indicated are milky white in color.

[E] : Indicates the connector shapes which are used to join wire harnesses.
On Left : Female connector shapes
On Right : Male connector shapes
Numbers indicate pin numbers.

[F] : Indicates connector colors. (Connectors with not indicated colors are white)

L PART NUMBER OF CONNECTORS

Code	Part Name	Part Number	Code	Part Name	Part Number
A1	Turn Signal Lamp (Front RH)	90980-11019	B22	Door Courtesy SW (Front LH)	90980-12470
A2	Inlet Air Temp. Sensor	90980-11163	B23	Front Seat Outer Belt (LH)	90980-12253
A3	Air Flow Meter	90980-12292	B24	Blower SW (Rear Heater)	90980-10463
A4	A/C Pressure Sensor	90980-10845	B25	Front Seat Outer Belt (RH)	90980-12253
A5	Pressure SW	90980-10943	B26	Door Courtesy SW (Front RH)	90980-12470
A6	Clearance Lamp (Front RH)	90980-11156	B27	Cooling Fan ECU No.1	90980-10841
[A]	Headlamp [B] (LH)	90980-[C] 314	B28	Cooling Fan ECU No.2	
A8	Headlamp Leveling Motor (RH)	90980-11016	B29	Water Temp. Sensor (Radiator)	90980-10735
A9	Brake Vacuum Warning SW	90980-11252	B30	Fuel Filter Warning SW	90980-11003
A10	Brake Fluid Level Warning SW	90980-11207	B32	Door Control Relay (LH)	90980-10789
A11	Windshield Washer Motor	90980-11599	B33	Step Lamp (LH)	90980-10121
A12	Airbag Sensor (Front RH)	90980-11856	B34	Junction Connector	
A13	Airbag Sensor (Front LH)	90980-12490	B35	Junction Connector	90980-11398

[A] : Part Code

[B] : Part Name

[C] : Part Number

Toyota Part Number are indicated.

Not all of the above part numbers of the connector are established for the supply.

C TROUBLESHOOTING

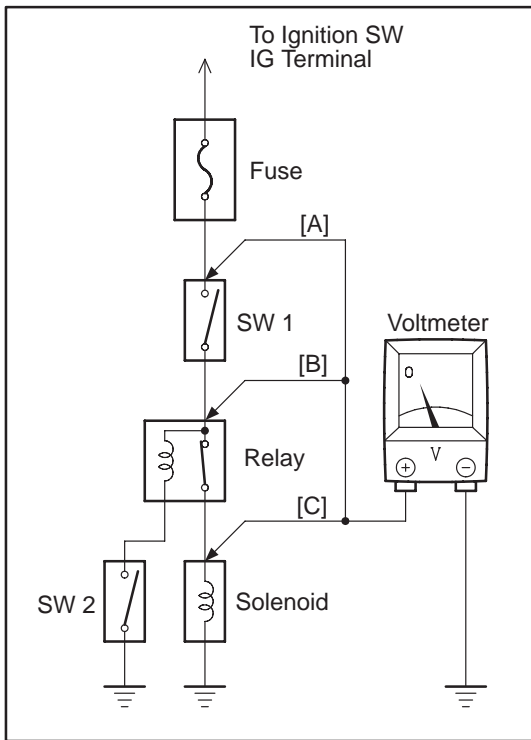

VOLTAGE CHECK

- (a) Establish conditions in which voltage is present at the check point.

Example:

- [A] – Ignition SW on
- [B] – Ignition SW and SW 1 on
- [C] – Ignition SW, SW 1 and Relay on (SW 2 off)

- (b) Using a voltmeter, connect the negative lead to a good ground point or negative battery terminal, and the positive lead to the connector or component terminal. This check can be done with a test light instead of a voltmeter.

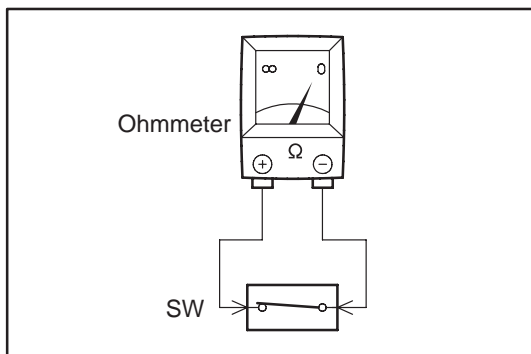

CONTINUITY AND RESISTANCE CHECK

- (a) Disconnect the battery terminal or wire so there is no voltage between the check points.
- (b) Contact the two leads of an ohmmeter to each of the check points.

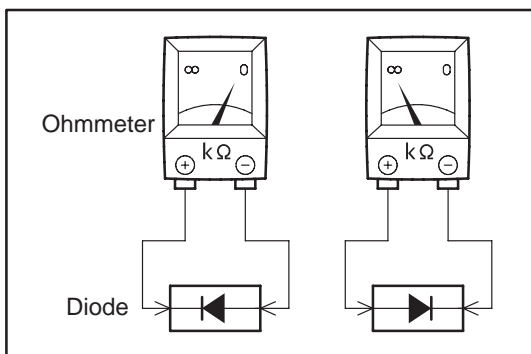

If the circuit has diodes, reverse the two leads and check again.

When contacting the negative lead to the diode positive side and the positive lead to the negative side, there should be continuity.

When contacting the two leads in reverse, there should be no continuity.

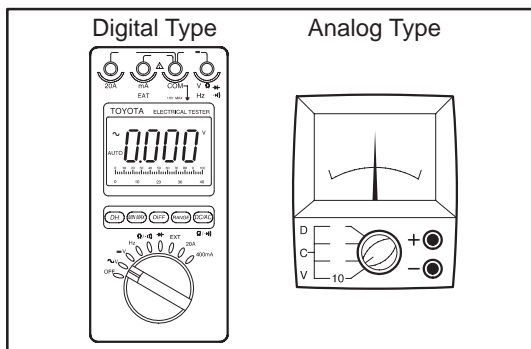

- (c) Use a volt/ohmmeter with high impedance (10 kΩ/V minimum) for troubleshooting of the electrical circuit.

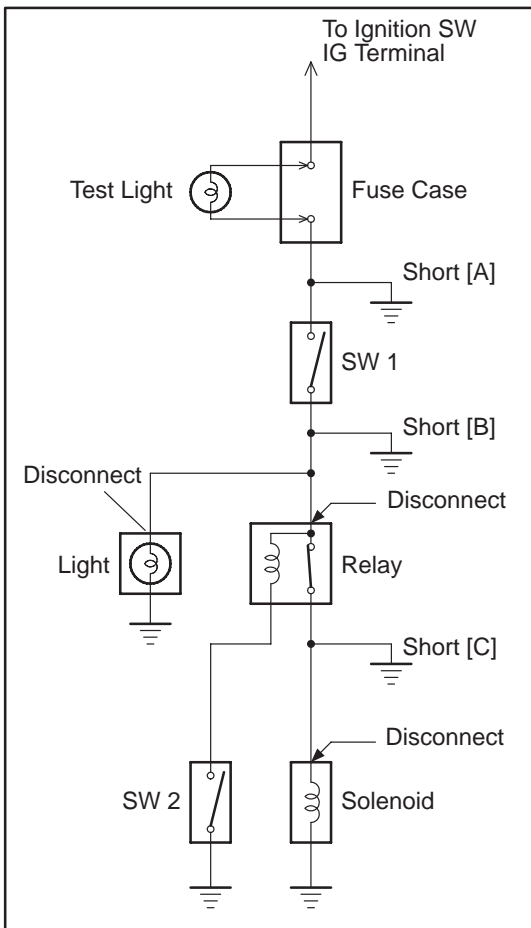

FINDING A SHORT CIRCUIT

- Remove the blown fuse and disconnect all loads of the fuse.
- Connect a test light in place of the fuse.
- Establish conditions in which the test light comes on.

Example:

- [A] – Ignition SW on
- [B] – Ignition SW and SW 1 on
- [C] – Ignition SW, SW 1 and Relay on (Connect the Relay) and SW 2 off (or Disconnect SW 2)

- Disconnect and reconnect the connectors while watching the test light. The short lies between the connector where the test light stays lit and the connector where the light goes out.
- Find the exact location of the short by lightly shaking the problem wire along the body.

CAUTION:

- Do not open the cover or the case of the ECU unless absolutely necessary. (If the IC terminals are touched, the IC may be destroyed by static electricity.)
- When replacing the internal mechanism (ECU part) of the digital meter, be careful that no part of your body or clothing comes in contact with the terminals of leads from the IC, etc. of the replacement part (spare part).

DISCONNECTION OF MALE AND FEMALE CONNECTORS

To pull apart the connectors, pull on the connector itself, not the wire harness.

HINT: Check to see what kind of connector you are disconnecting before pulling apart.

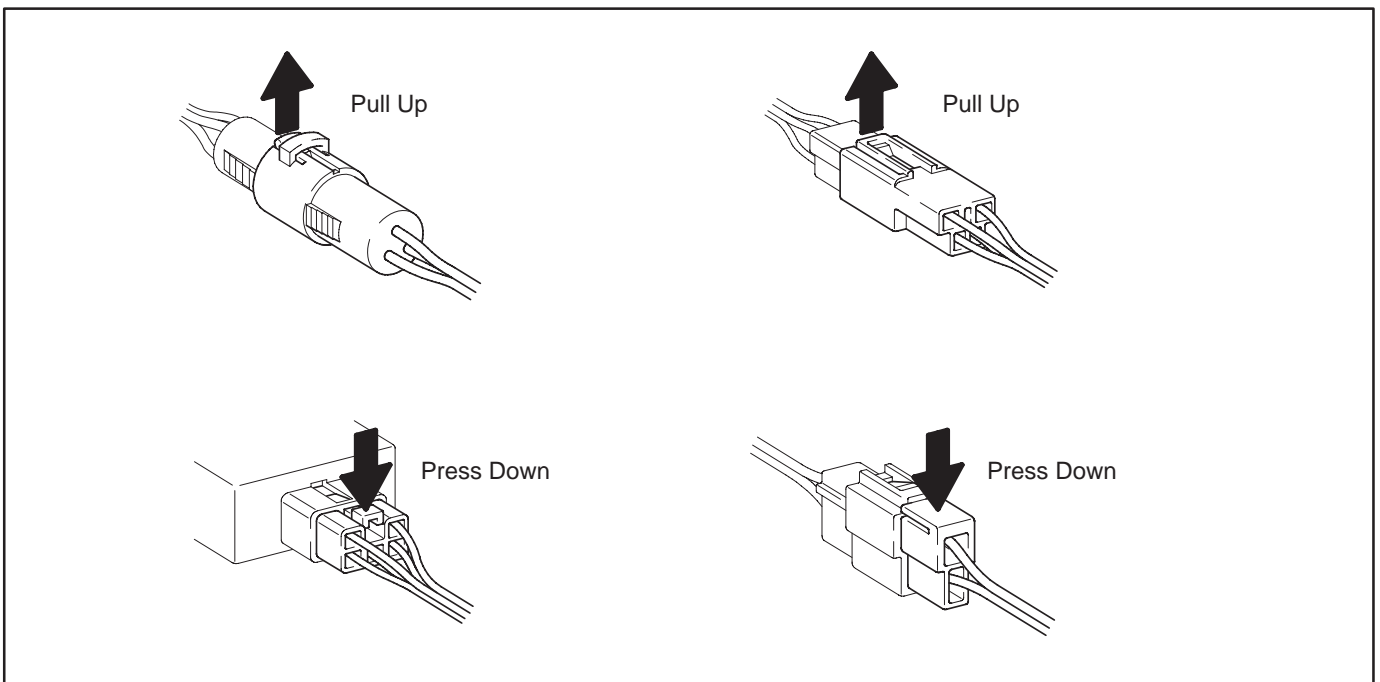

C TROUBLESHOOTING

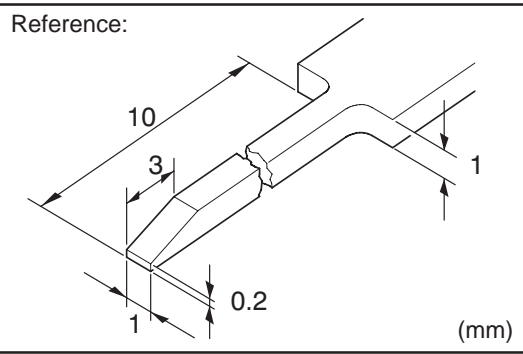

HOW TO REPLACE TERMINAL (with terminal retainer or secondary locking device)

1. PREPARE THE SPECIAL TOOL

HINT : To remove the terminal from the connector, please construct and use the special tool or like object shown on the left.

2. DISCONNECT CONNECTOR

3. DISENGAGE THE SECONDARY LOCKING DEVICE OR TERMINAL RETAINER.

(a) Locking device must be disengaged before the terminal locking clip can be released and the terminal removed from the connector.

(b) Use a special tool or the terminal pick to unlock the secondary locking device or terminal retainer.

NOTICE:

Do not remove the terminal retainer from connector body.

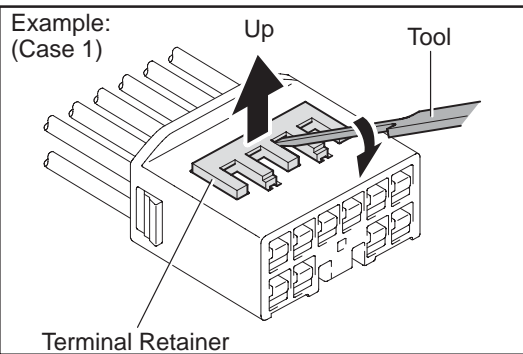

[A] For Non-Waterproof Type Connector

HINT : The needle insertion position varies according to the connector's shape (number of terminals etc.), so check the position before inserting it.

"Case 1"

Raise the terminal retainer up to the temporary lock position.

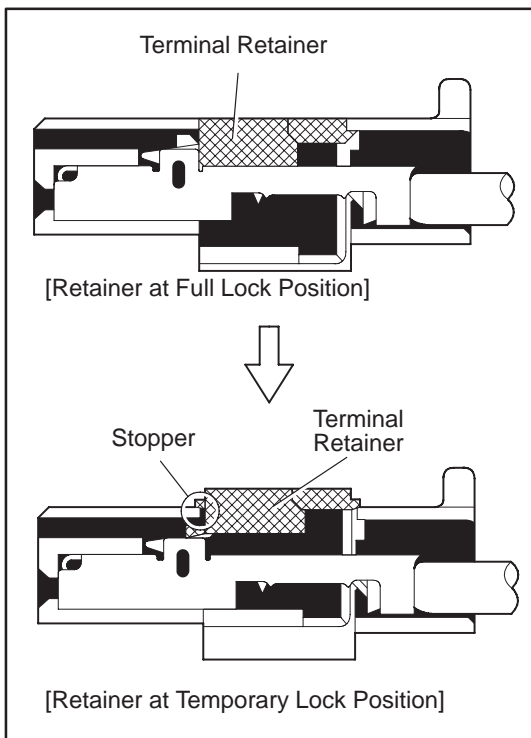

"Case 2"

Open the secondary locking device.

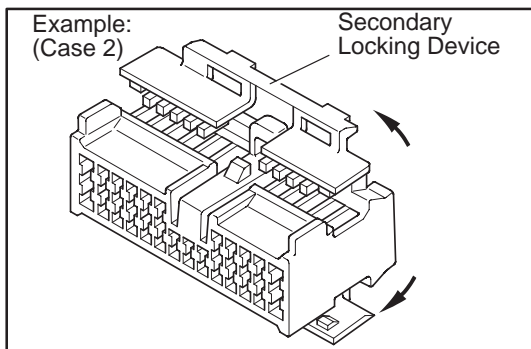

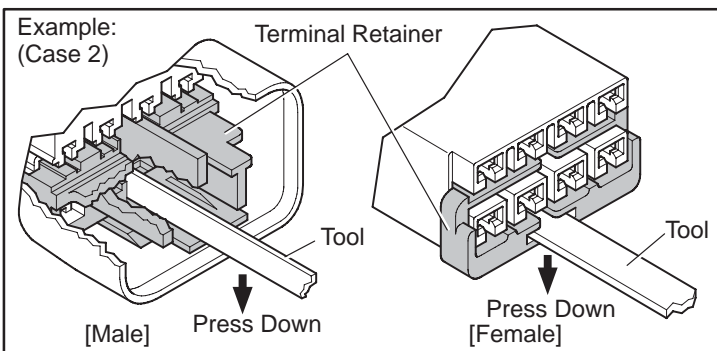
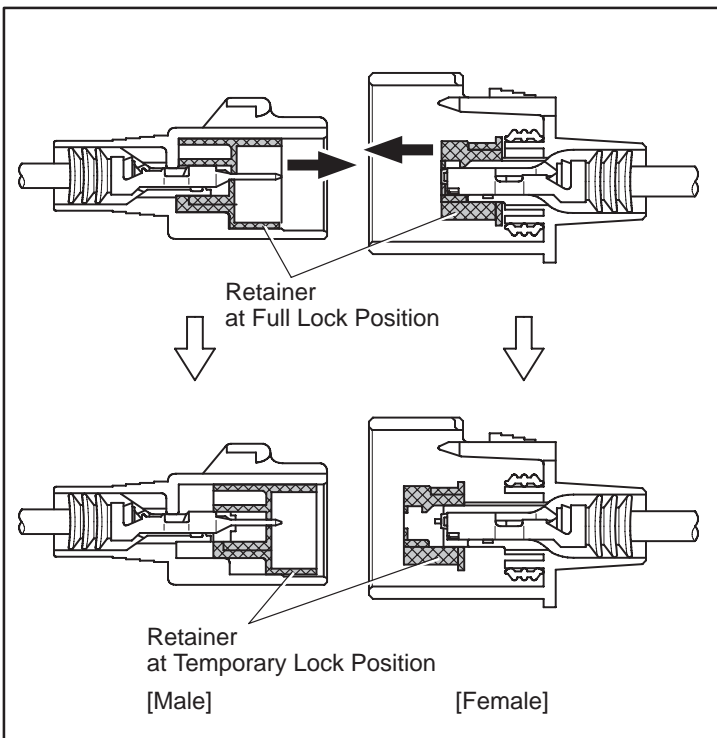
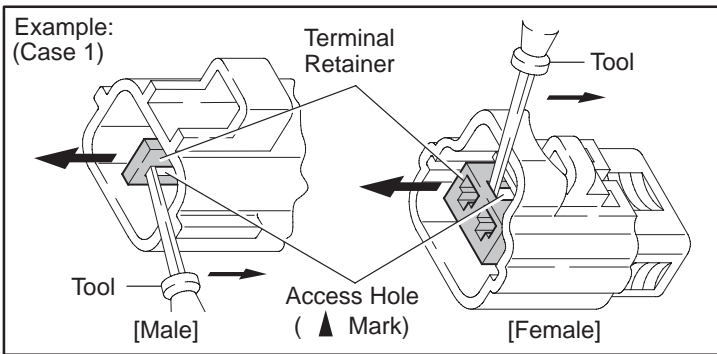
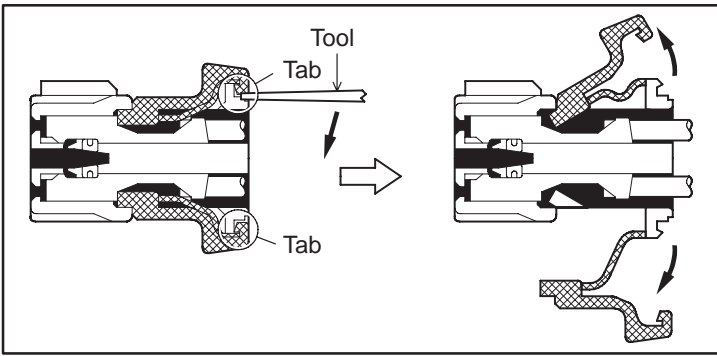

[B] For Waterproof Type Connector

HINT : Terminal retainer color is different according to connector body.

Example:

Terminal Retainer	Connector Body
Black or White	Gray
Black or White	Dark Gray
Gray or White	Black

"Case 1"

Type where terminal retainer is pulled up to the temporary lock position (Pull Type).

Insert the special tool into the terminal retainer access hole (▲Mark) and pull the terminal retainer up to the temporary lock position.

HINT : The needle insertion position varies according to the connector's shape (Number of terminals etc.), so check the position before inserting it.

"Case 2"

Type which cannot be pulled as far as Power Lock insert the tool straight into the access hole of terminal retainer as shown.

C TROUBLESHOOTING

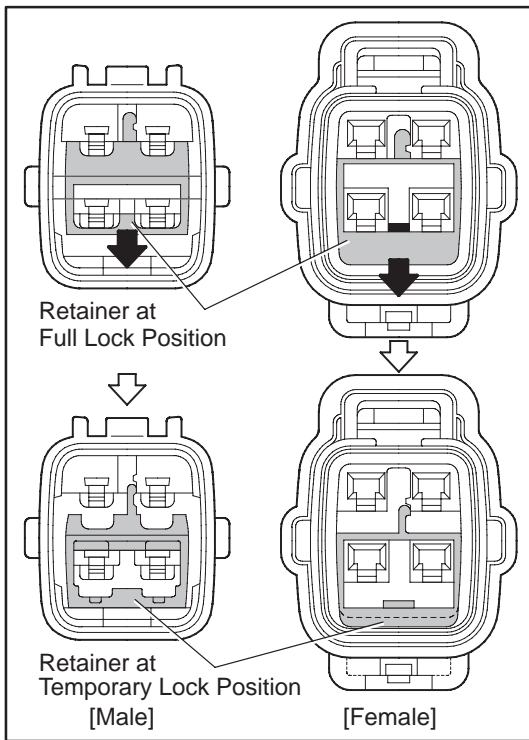

Push the terminal retainer down to the temporary lock position.

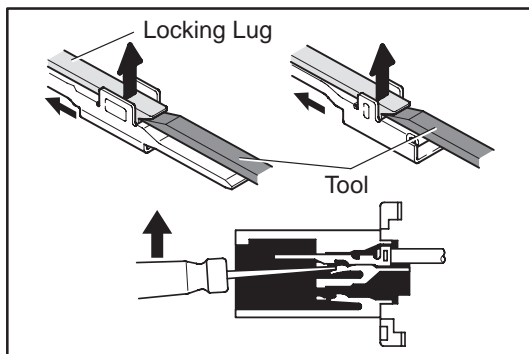

(c) Release the locking lug from terminal and pull the terminal out from rear.

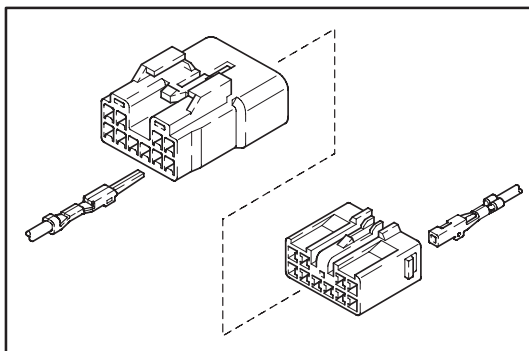

4. INSTALL TERMINAL TO CONNECTOR

(a) Insert the terminal.

HINT:

1. Make sure the terminal is positioned correctly.
2. Insert the terminal until the locking lug locks firmly.
3. Insert the terminal with terminal retainer in the temporary lock position.

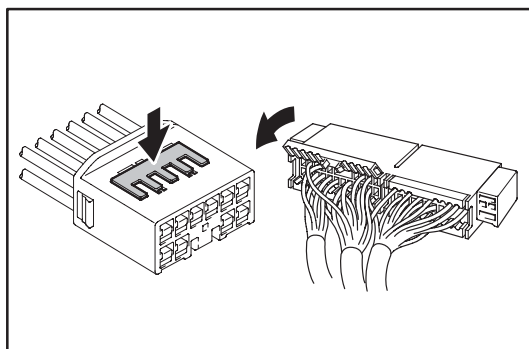

(b) Push the secondary locking device or terminal retainer in to the full lock position.

5. CONNECT CONNECTOR











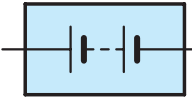

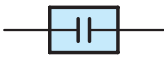





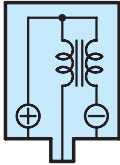

ABBREVIATIONS





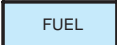

The following abbreviations are used in this manual.

2WD	=	Two Wheel Drive Vehicles
4WD	=	Four Wheel Drive Vehicles
A/C	=	Air Conditioning
A/T	=	Automatic Transmission
ABS	=	Anti-Lock Brake System
ACIS	=	Acoustic Control Induction System
ADD	=	Automatic Disconnecting Differential
BEAN	=	Body Electronics Area Network
CAN	=	Controller Area Network
DIFF.	=	Differential
EBD	=	Electronic Brake Force Distribution
EC	=	Electrochromic
ECU	=	Electronic Control Unit
ESA	=	Electronic Spark Advance
ETCS-i	=	Electronic Throttle Control System-intelligent
IC	=	Integrated Circuit
J/B	=	Junction Block
LH	=	Left-Hand
LSD	=	Limited Slip Differential
M/T	=	Manual Transmission
R/B	=	Relay Block
RH	=	Right-Hand
SFI	=	Sequential Multiport Fuel Injection
SRS	=	Supplemental Restraint System
SW	=	Switch
TEMP.	=	Temperature
TRAC	=	Traction Control
TVIP	=	TOYOTA Vehicle Intrusion Protection
VSC	=	Vehicle Stability Control
VSV	=	Vacuum Switching Valve
VVT	=	Variable Valve Timing
VVT-i	=	Variable Valve Timing-intelligent
w/	=	With
w/o	=	Without

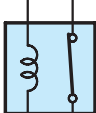
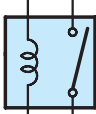
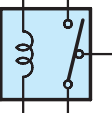
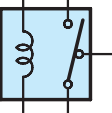
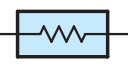
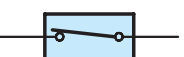
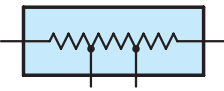
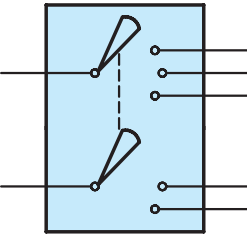
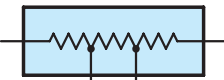
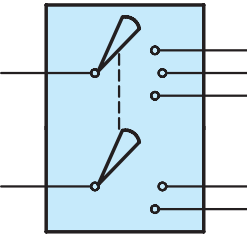
* The titles given inside the components are the names of the terminals (terminal codes) and are not treated as being abbreviations.

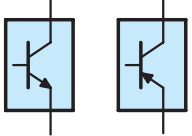
E GLOSSARY OF TERMS AND SYMBOLS

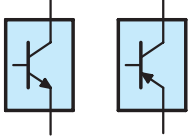
 <p>BATTERY Stores chemical energy and converts it into electrical energy. Provides DC current for the auto's various electrical circuits.</p>	 <p>GROUND The point at which wiring attaches to the Body, thereby providing a return path for an electrical circuit; without a ground, current cannot flow.</p>
 <p>CAPACITOR (Condenser) A small holding unit for temporary storage of electrical voltage.</p>	<p>HEADLIGHTS Current flow causes a headlight filament to heat up and emit light. A headlight may have either a single (1) filament or a double (2) filament</p> <p>1. SINGLE FILAMENT</p>  <p>2. DOUBLE FILAMENT</p> 
 <p>CIGARETTE LIGHTER An electric resistance heating element.</p>	
 <p>CIRCUIT BREAKER Basically a reusable fuse, a circuit breaker will heat and open if too much current flows through it. Some units automatically reset when cool, others must be manually reset.</p>	 <p>HORN An electric device which sounds a loud audible signal.</p>
 <p>DIODE A semiconductor which allows current flow in only one direction.</p>	 <p>IGNITION COIL Converts low-voltage DC current into high-voltage ignition current for firing the spark plugs.</p>
 <p>DIODE, ZENER A diode which allows current flow in one direction but blocks reverse flow only up to a specific voltage. Above that potential, it passes the excess voltage. This acts as a simple voltage regulator.</p>	 <p>LIGHT Current flow through a filament causes the filament to heat up and emit light.</p>
 <p>PHOTODIODE The photodiode is a semiconductor which controls the current flow according to the amount of light.</p>	 <p>LED (LIGHT EMITTING DIODE) Upon current flow, these diodes emit light without producing the heat of a comparable light.</p>
 <p>DISTRIBUTOR, IIA Channels high-voltage current from the ignition coil to the individual spark plugs.</p>	 <p>METER, ANALOG Current flow activates a magnetic coil which causes a needle to move, thereby providing a relative display against a background calibration.</p>
 <p>FUSE A thin metal strip which burns through when too much current flows through it, thereby stopping current flow and protecting a circuit from damage.</p>  <p>FUSIBLE LINK (for Medium Current Fuse) A heavy-gauge wire placed in high amperage circuits which burns through on overloads, thereby protecting the circuit. The numbers indicate the crosssection surface area of the wires.</p>  <p>(for High Current Fuse or Fusible Link)</p>	 <p>METER, DIGITAL Current flow activates one or many LED's, LCD's, or fluorescent displays, which provide a relative or digital display.</p>
	 <p>MOTOR A power unit which converts electrical energy into mechanical energy, especially rotary motion.</p>

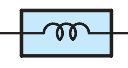
 <p>RELAY Basically, an electrically operated switch which may be normally closed (1) or open (2). Current flow through a small coil creates a magnetic field which either opens or closes an attached switch.</p> <p>1. NORMALLY CLOSED</p> <p>2. NORMALLY OPEN</p>	 <p>SPEAKER An electromechanical device which creates sound waves from current flow.</p>
 <p>RELAY, DOUBLE THROW A relay which passes current through one set of contacts or the other.</p>	<p>SWITCH, MANUAL Opens and closes circuits, thereby stopping (1) or allowing (2) current flow.</p>  <p>1. NORMALLY OPEN</p> <p>2. NORMALLY CLOSED</p>
 <p>RESISTOR An electrical component with a fixed resistance, placed in a circuit to reduce voltage to a specific value.</p>	<p>SWITCH, DOUBLE THROW A switch which continuously passes current through one set of contacts or the other.</p> 
 <p>RESISTOR, TAPPED A resistor which supplies two or more different non adjustable resistance values.</p>	<p>SWITCH, IGNITION A key operated switch with several positions which allows various circuits, particularly the primary ignition circuit, to become operational.</p> 
 <p>RESISTOR, VARIABLE or RHEOSTAT A controllable resistor with a variable rate of resistance. Also called a potentiometer or rheostat.</p>	<p>SWITCH, WIPER PARK Automatically returns wipers to the stop position when the wiper switch is turned off.</p> 
 <p>SENSOR (Thermistor) A resistor which varies its resistance with temperature.</p>	<p>TRANSISTOR A solidstate device typically used as an electronic relay; stops or passes current depending on the voltage applied at "base".</p> 
 <p>SENSOR, SPEED Uses magnetic impulses to open and close a switch to create a signal for activation of other components. (Reed Switch Type)</p>	<p>WIRES Wires are always drawn as straight lines on wiring diagrams. Crossed wires (1) without a black dot at the junction are not joined; crossed wires (2) with a black dot or octagonal (○) mark at the junction are spliced (joined) connections.</p>  <p>(1) NOT CONNECTED</p> <p>(2) SPLICED</p>
 <p>SHORT PIN Used to provide an unbroken connection within a junction block.</p>	
 <p>SOLENOID An electromagnetic coil which forms a magnetic field when current flows, to move a plunger, etc.</p>	

F RELAY LOCATIONS

[Engine Compartment]

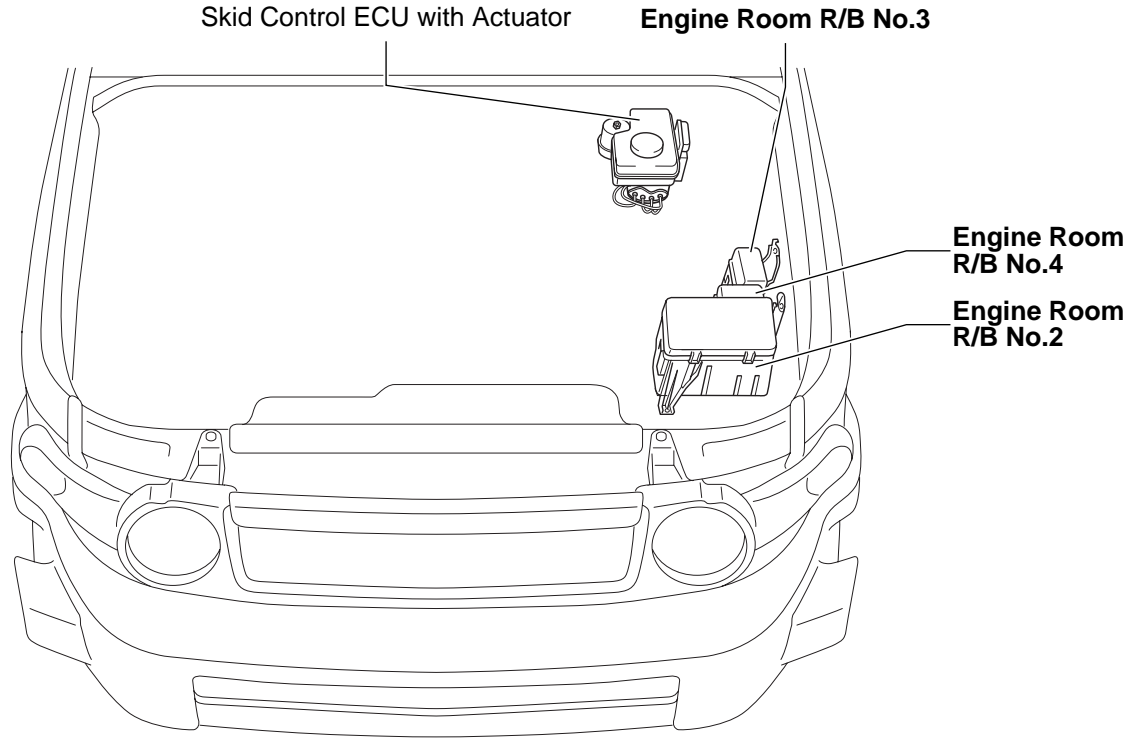

[Instrument Panel]

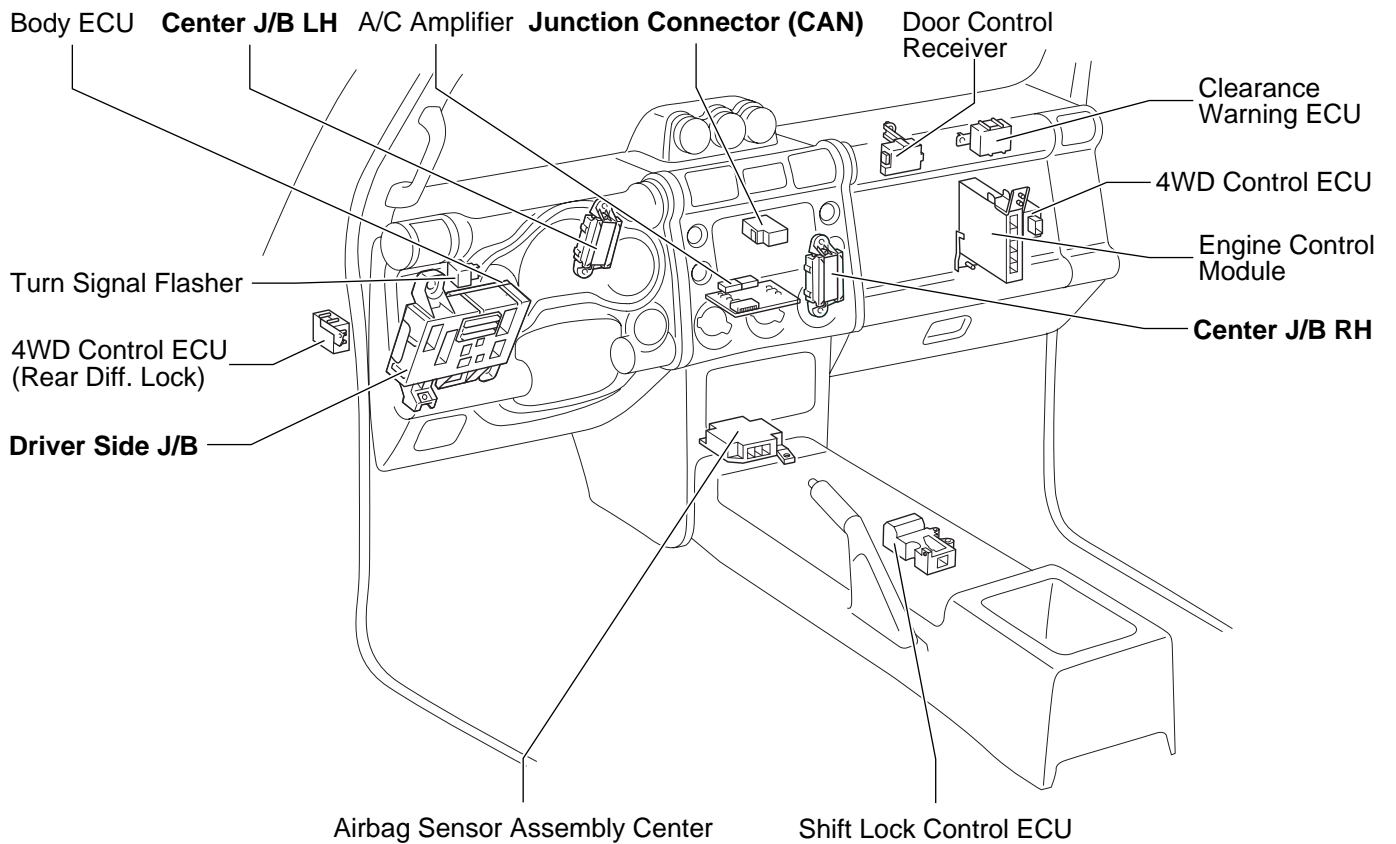

[Body]

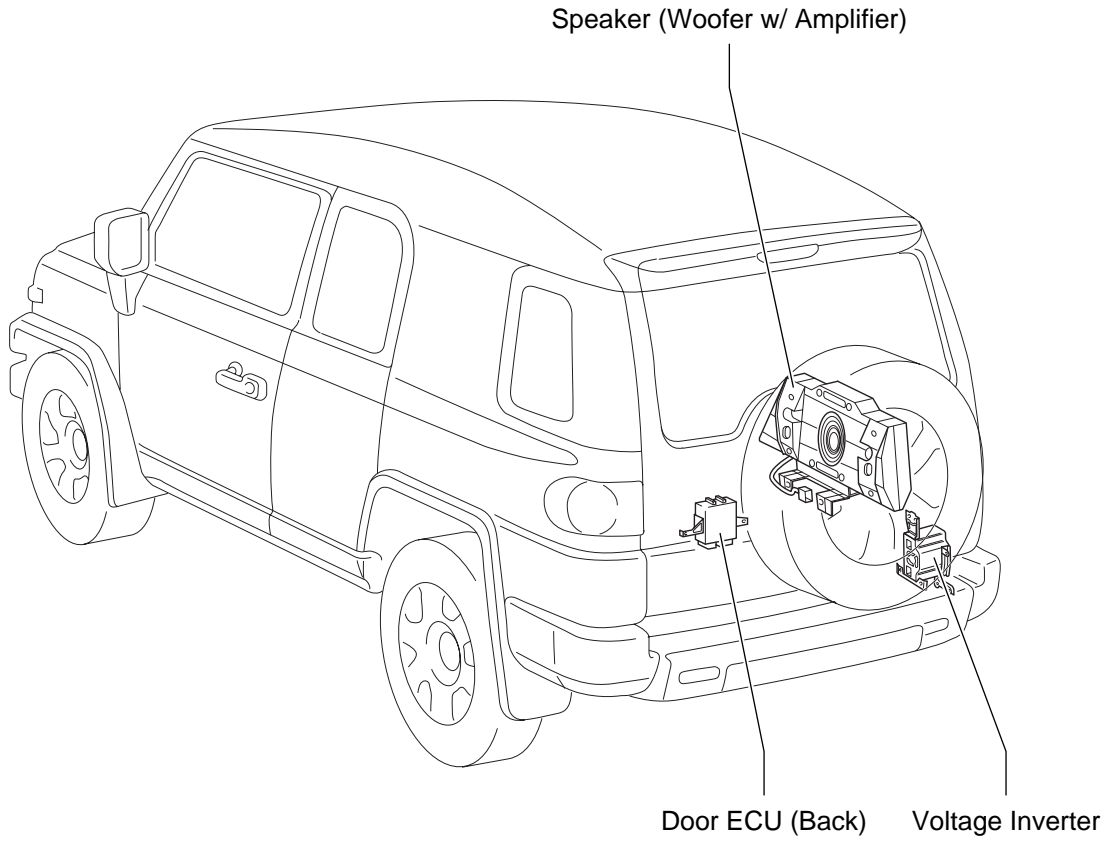

[Seat]

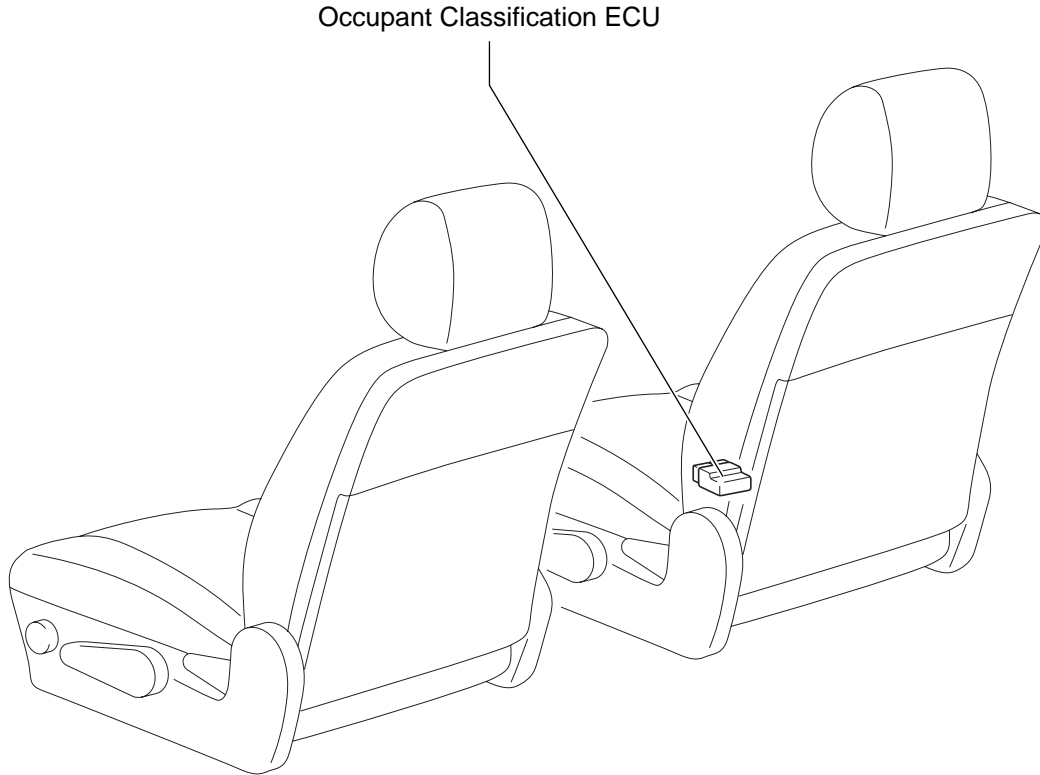

F RELAY LOCATIONS

② : Engine Room R/B No.2 Engine Compartment Left (See Page 20)

- * 1: STA Relay
- * 2: MG CLT Relay
- * 3: AUX LP Relay
- * 4: HEATER Relay
- * 5: TOWING TAIL Relay
- * 6: A/F HEATER Relay
- * 7: EFI Relay
- * 8: DOME Relay
- * 9: C/OPN Relay
- * 10: RADIO NO.1
- * 11: HEAD(LO LH)
- * 12: HEAD(HI LH)

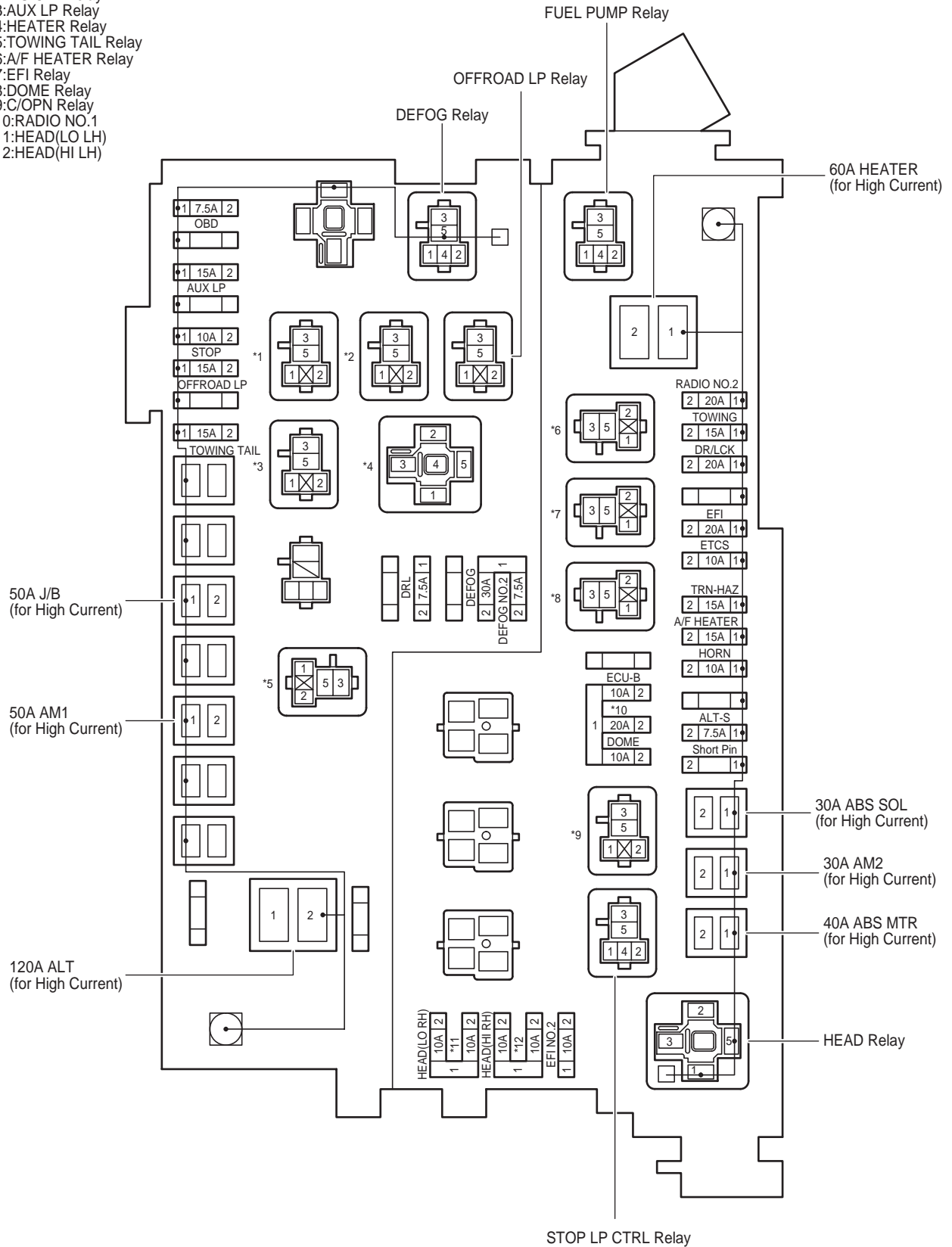

③ : Engine Room R/B No.3 Engine Compartment Left (See Page 20)

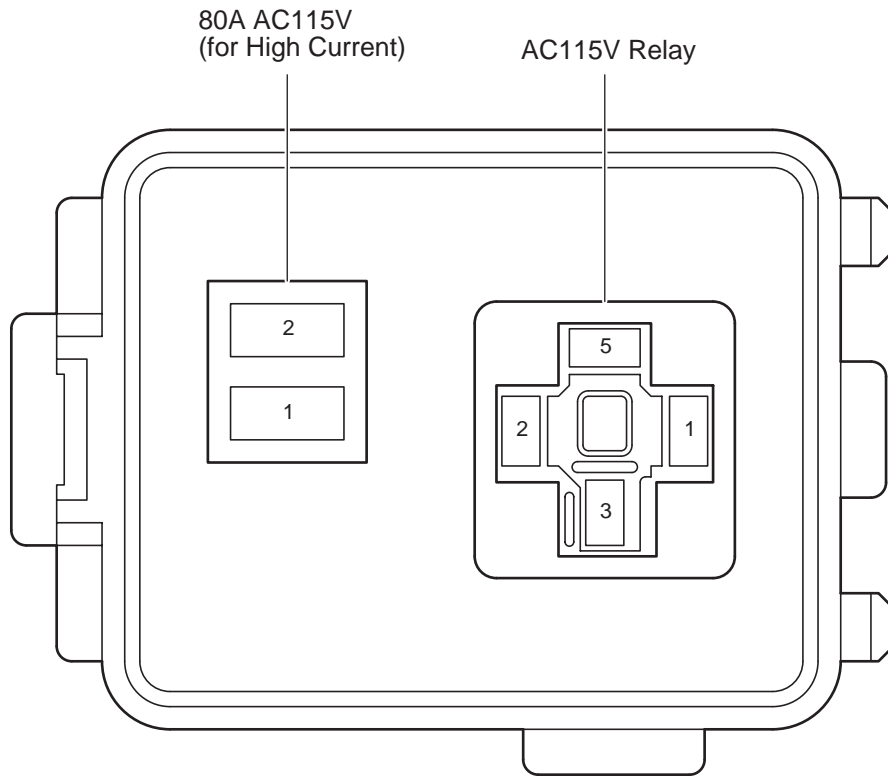

④ : Engine Room R/B No.4 Engine Compartment Left (See Page 20)

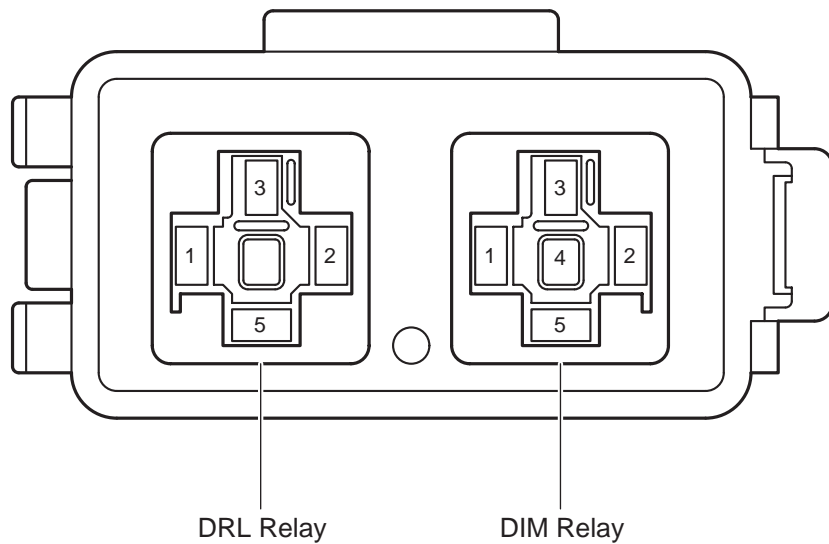

F RELAY LOCATIONS

○ : Driver Side J/B Lower Finish Panel (See Page 20)

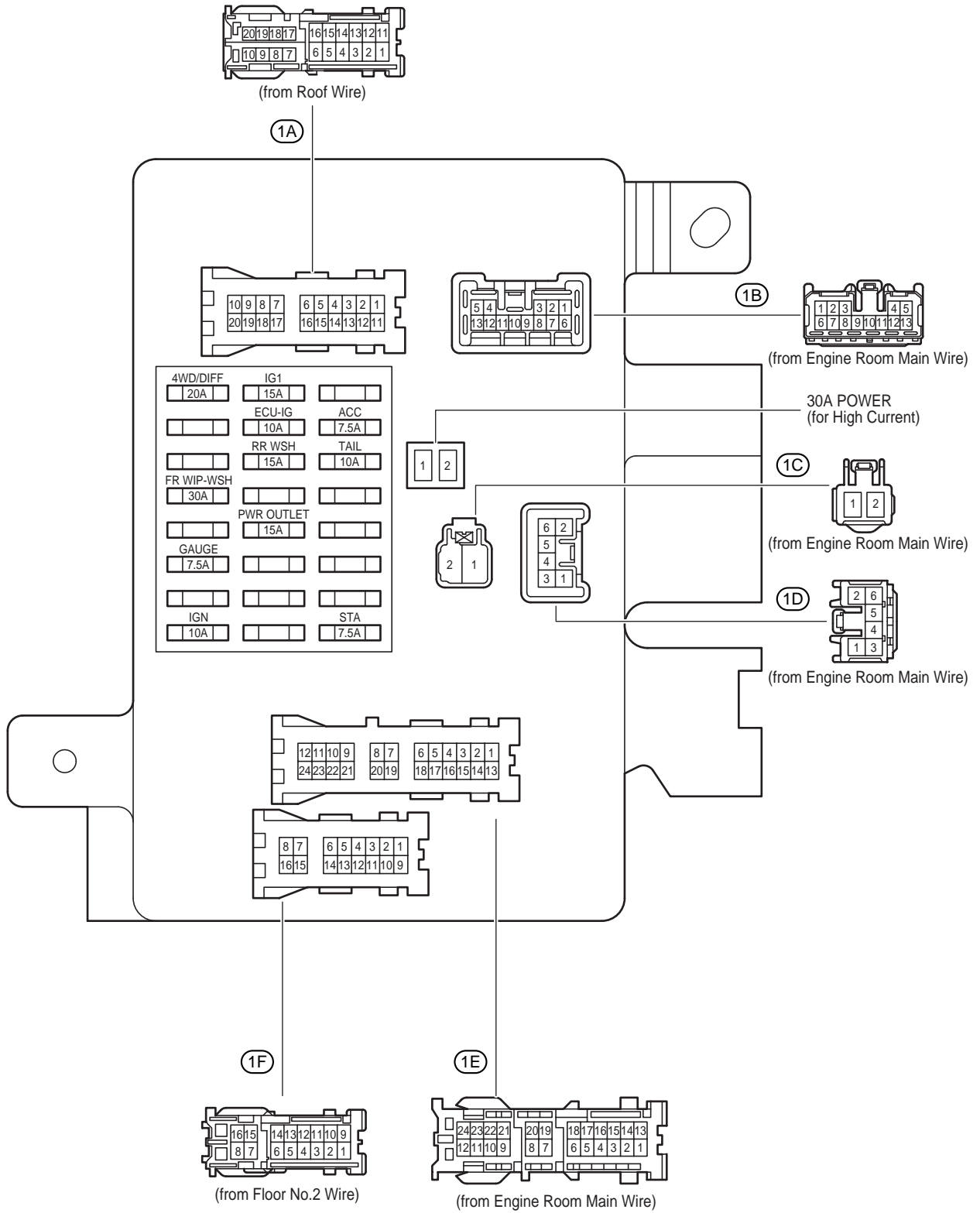

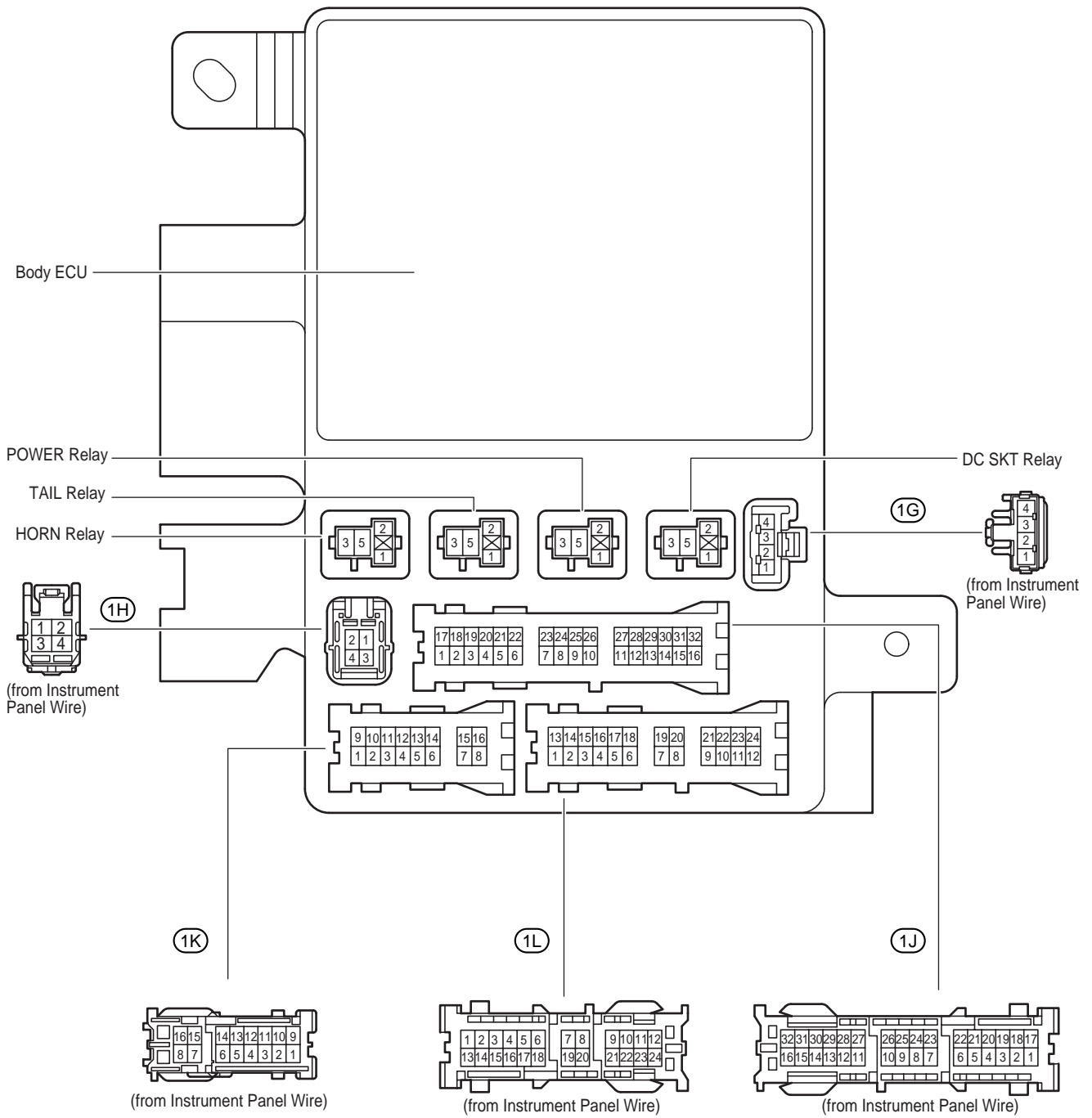

F RELAY LOCATIONS

[Driver Side J/B Inner Circuit]

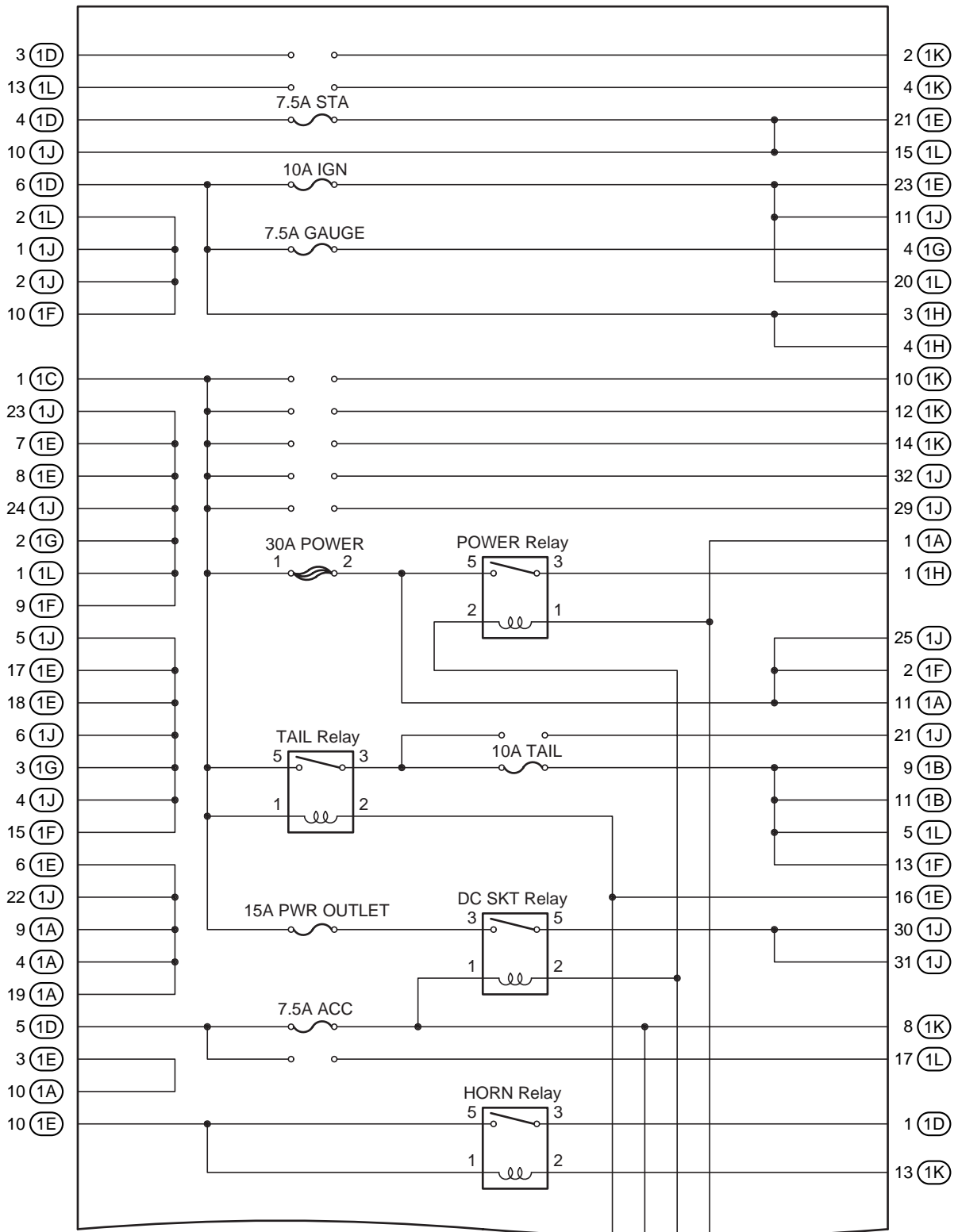

(Cont. Next Page)

(Cont'd)

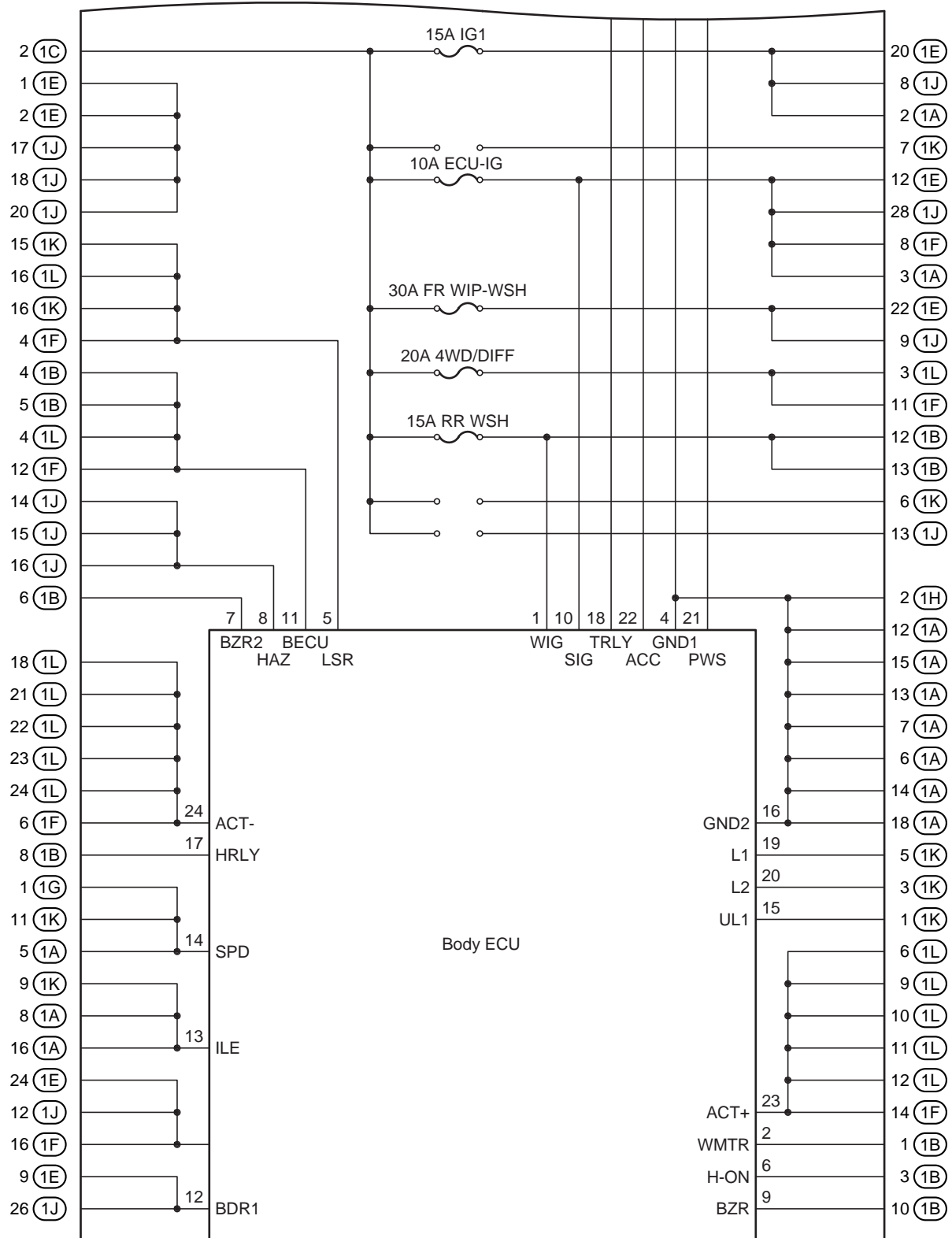

F RELAY LOCATIONS

○ : Center J/B LH Instrument Panel LH (See Page 20)

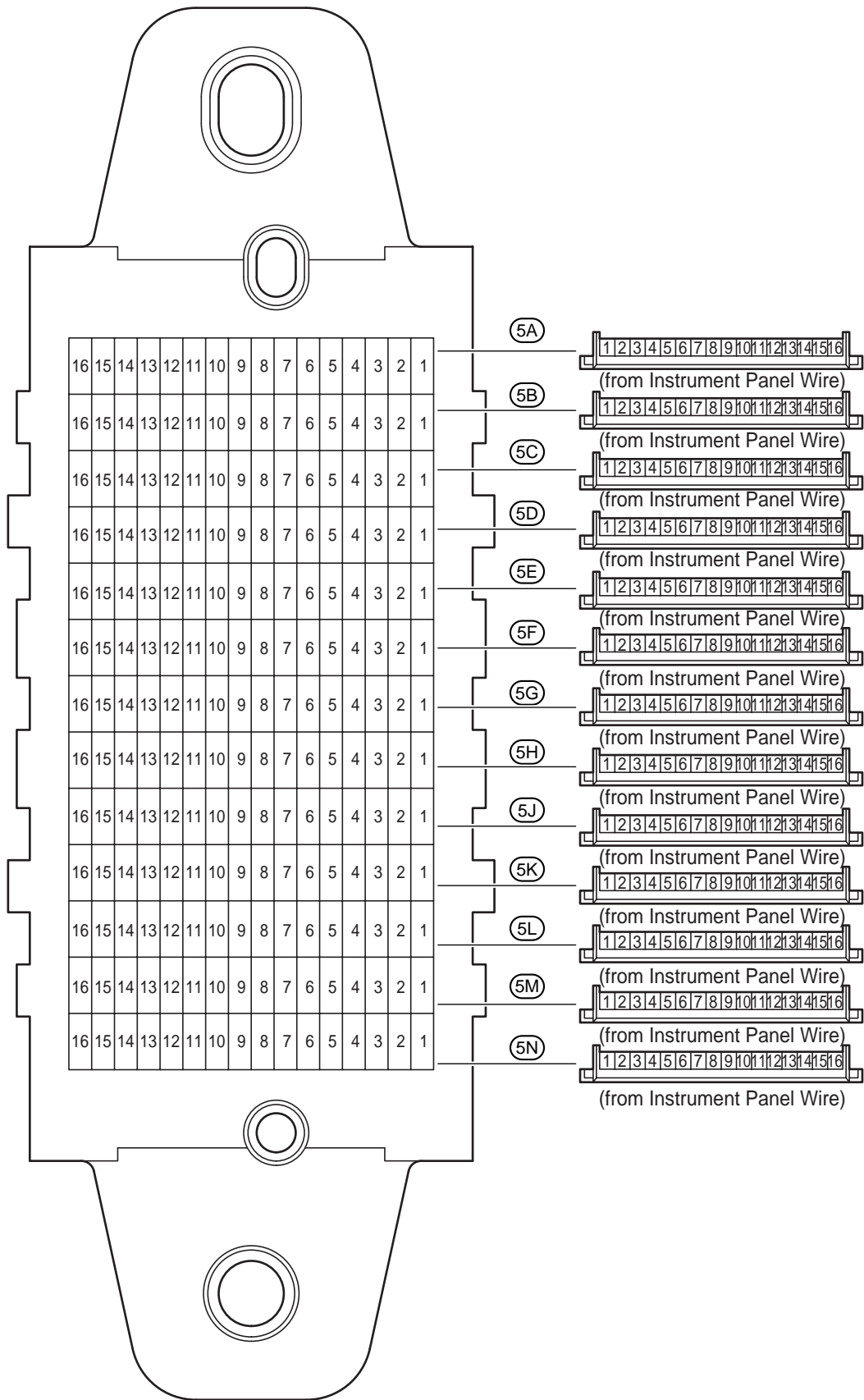

[Center J/B LH Inner Circuit]

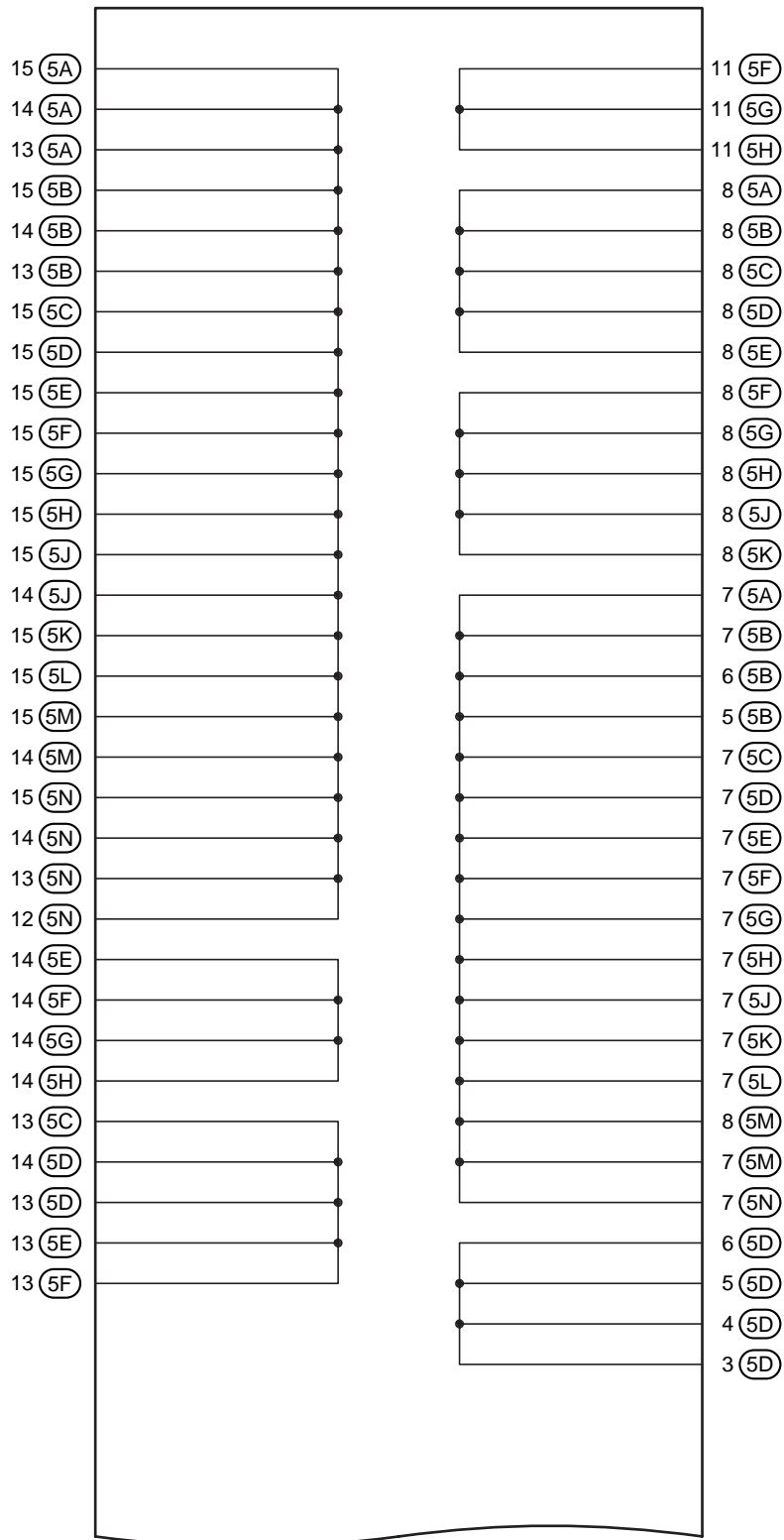

(Cont. Next Page)

F RELAY LOCATIONS

[Center J/B LH Inner Circuit]

(Cont'd)

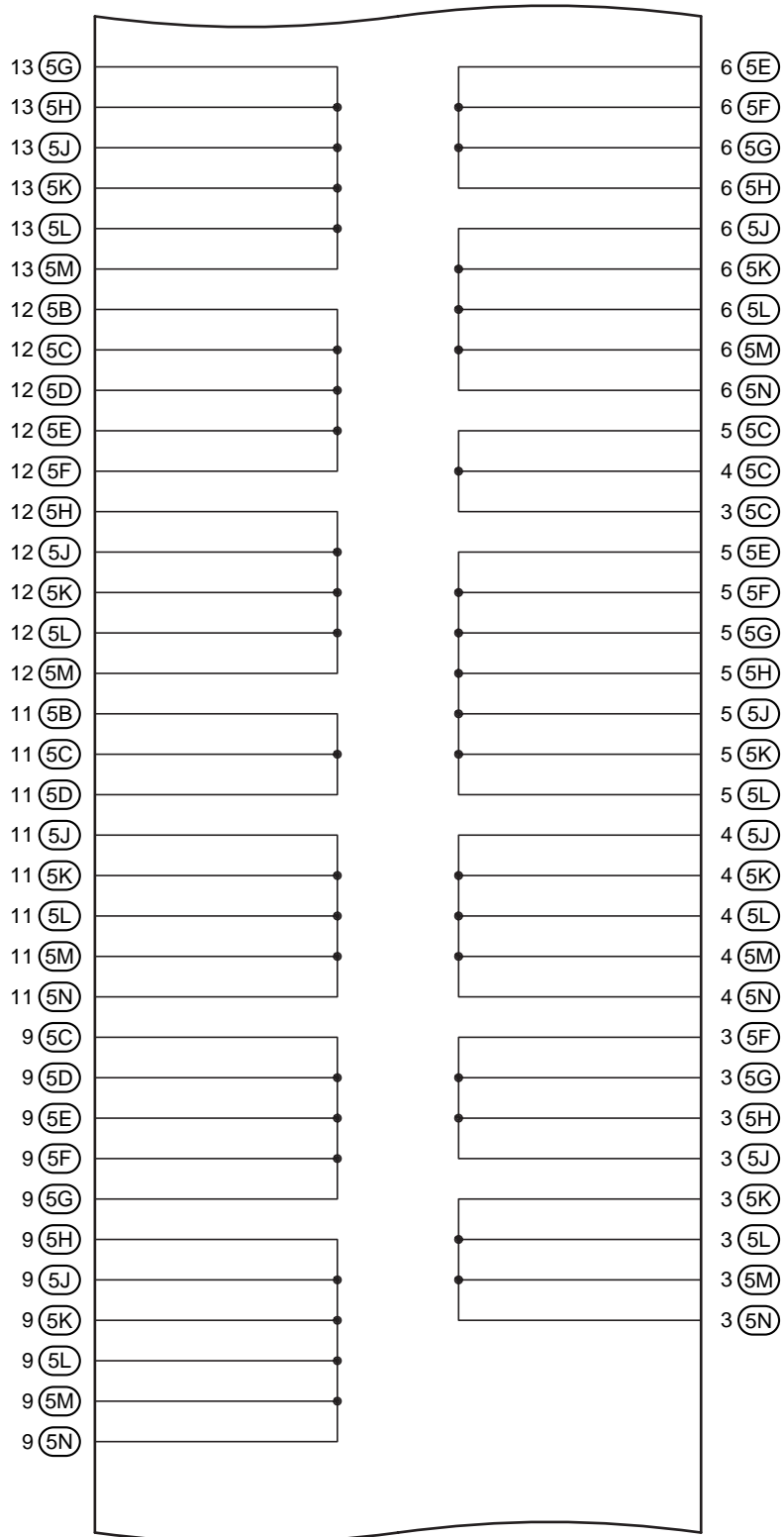

(Cont. Next Page)

(Cont'd)

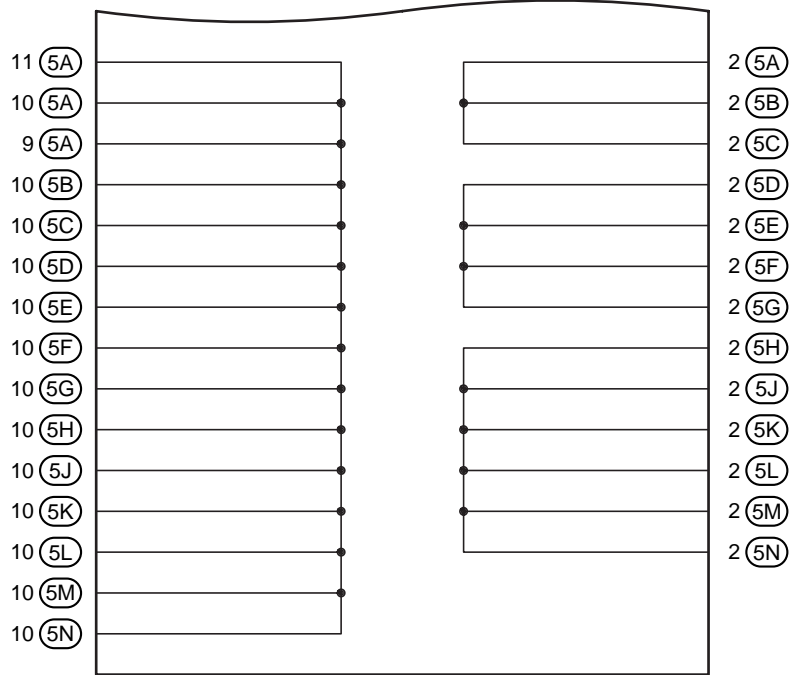

F RELAY LOCATIONS

○ : Center J/B RH Instrument Panel RH (See Page 20)

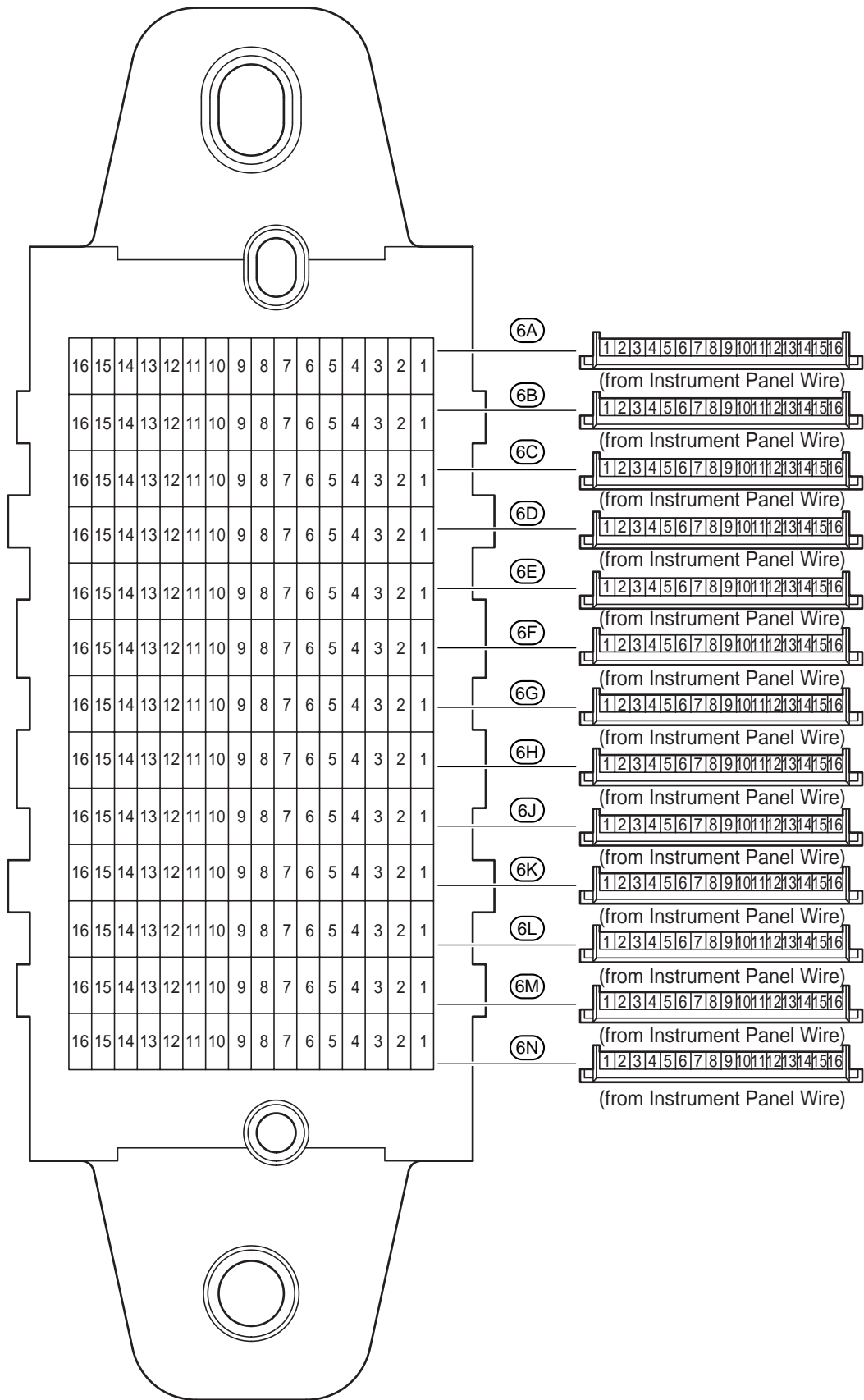

[Center J/B RH Inner Circuit]

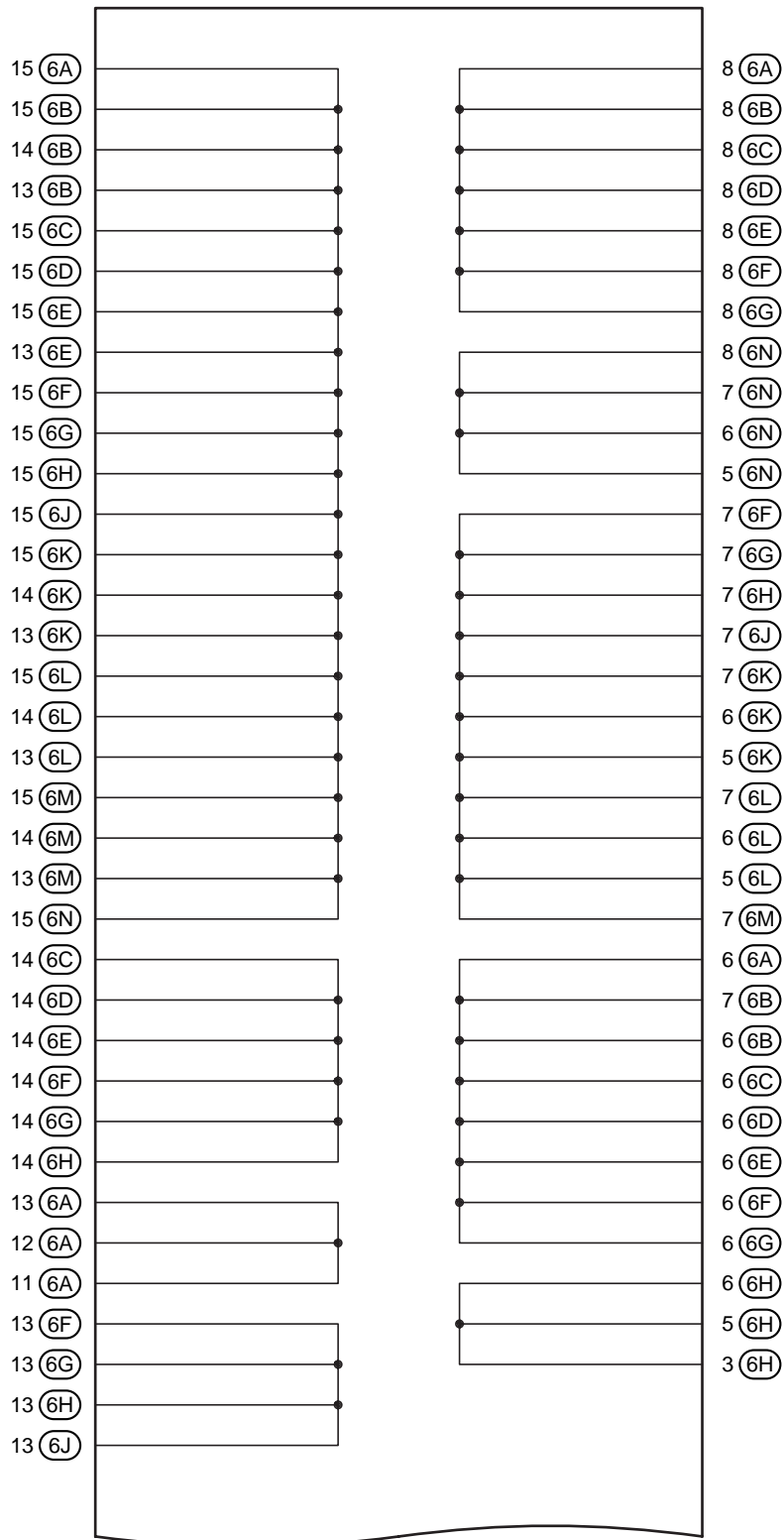

(Cont. Next Page)

F RELAY LOCATIONS

[Center J/B RH Inner Circuit]

(Cont'd)

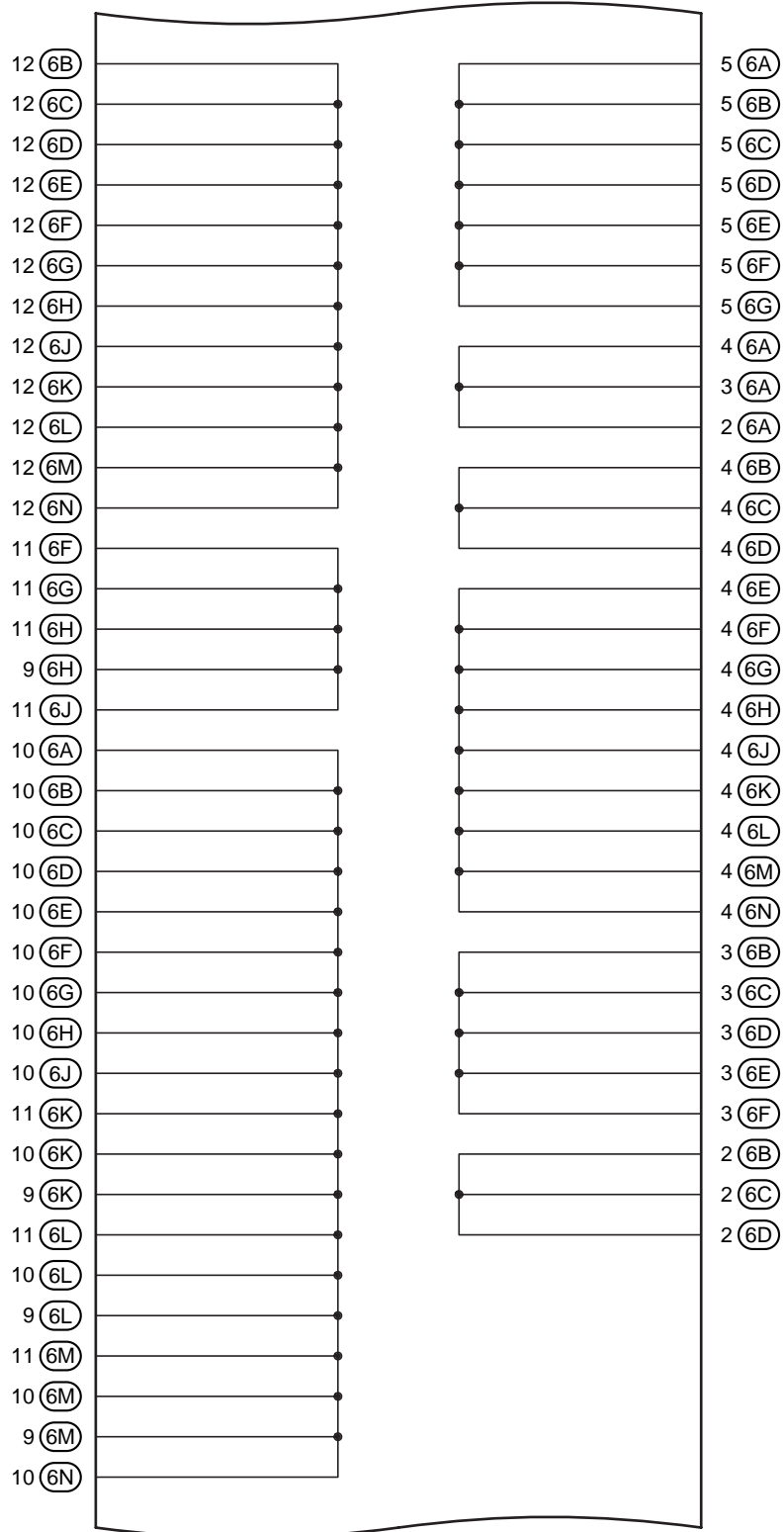

(Cont. Next Page)

(Cont'd)

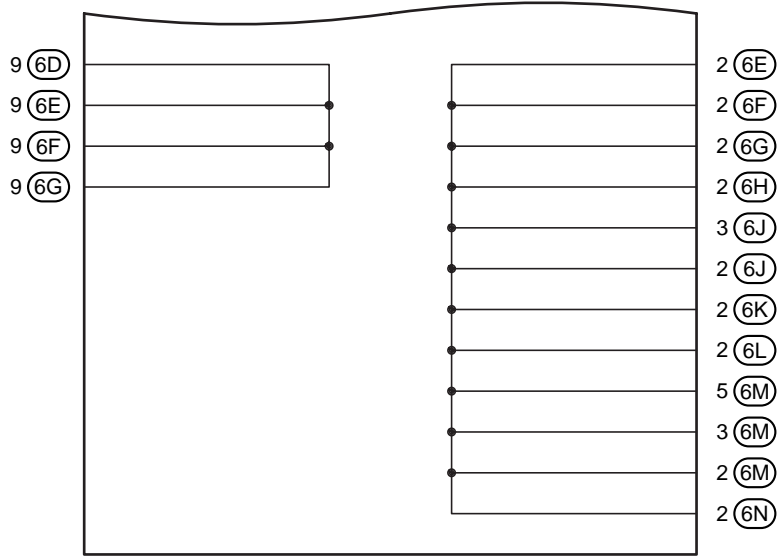

F RELAY LOCATIONS

Junction Connector

Instrument Panel Center (See Page 20)

(CAN)

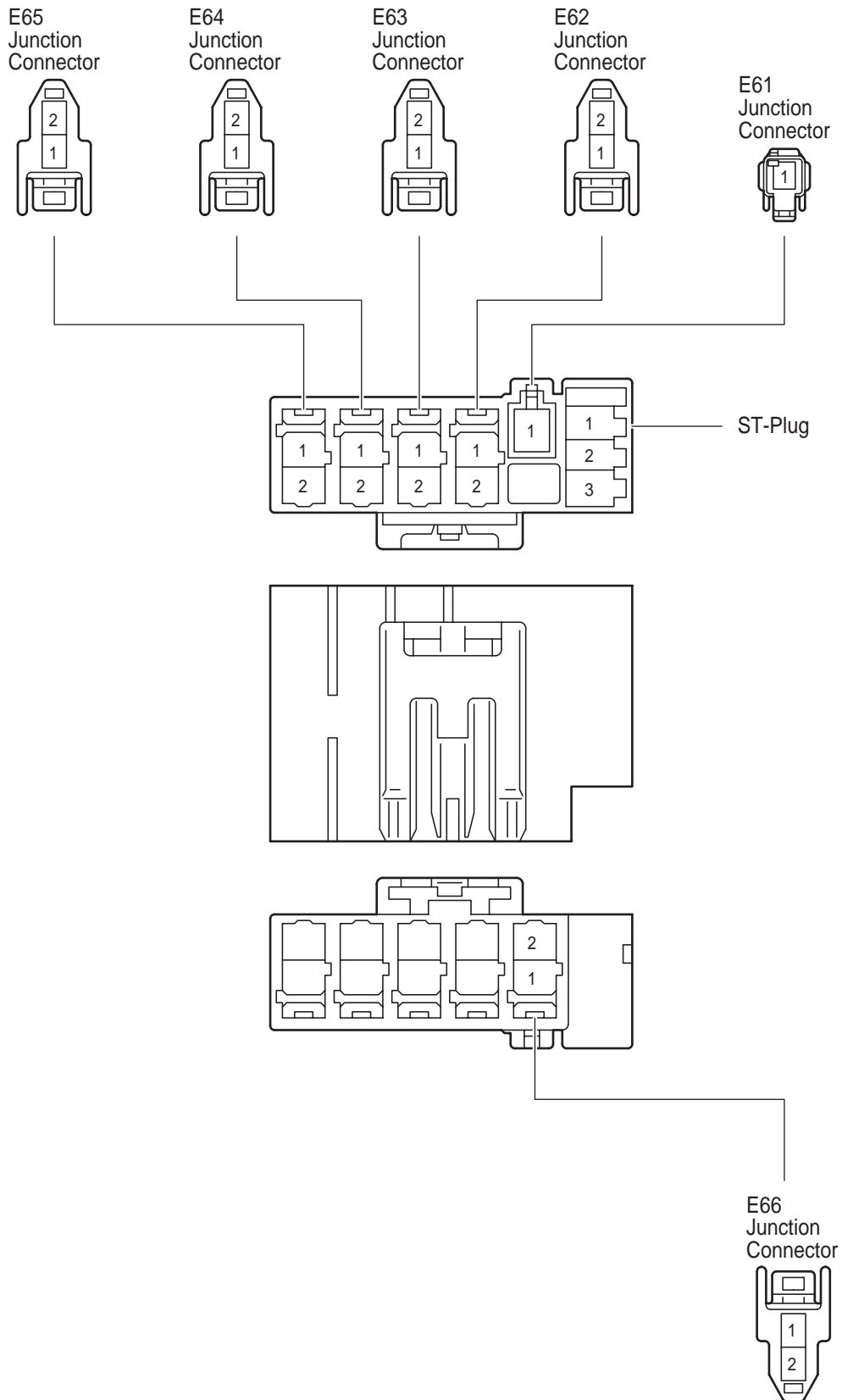

**[Junction Connector Inner Circuit]
(CAN)**

E61(A), E62(B), E63(C),
E64(D), E65(E), E66(F)
Junction Connector

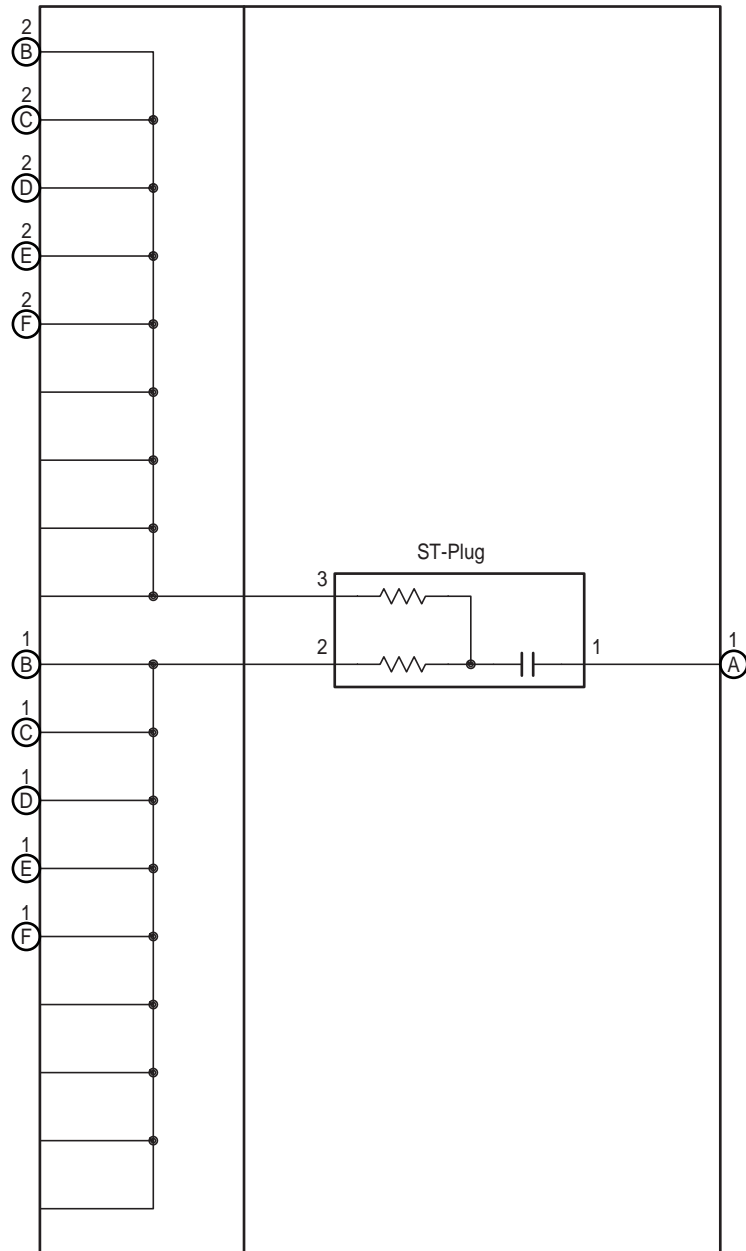

G ELECTRICAL WIRING ROUTING

Position of Parts in Engine Compartment

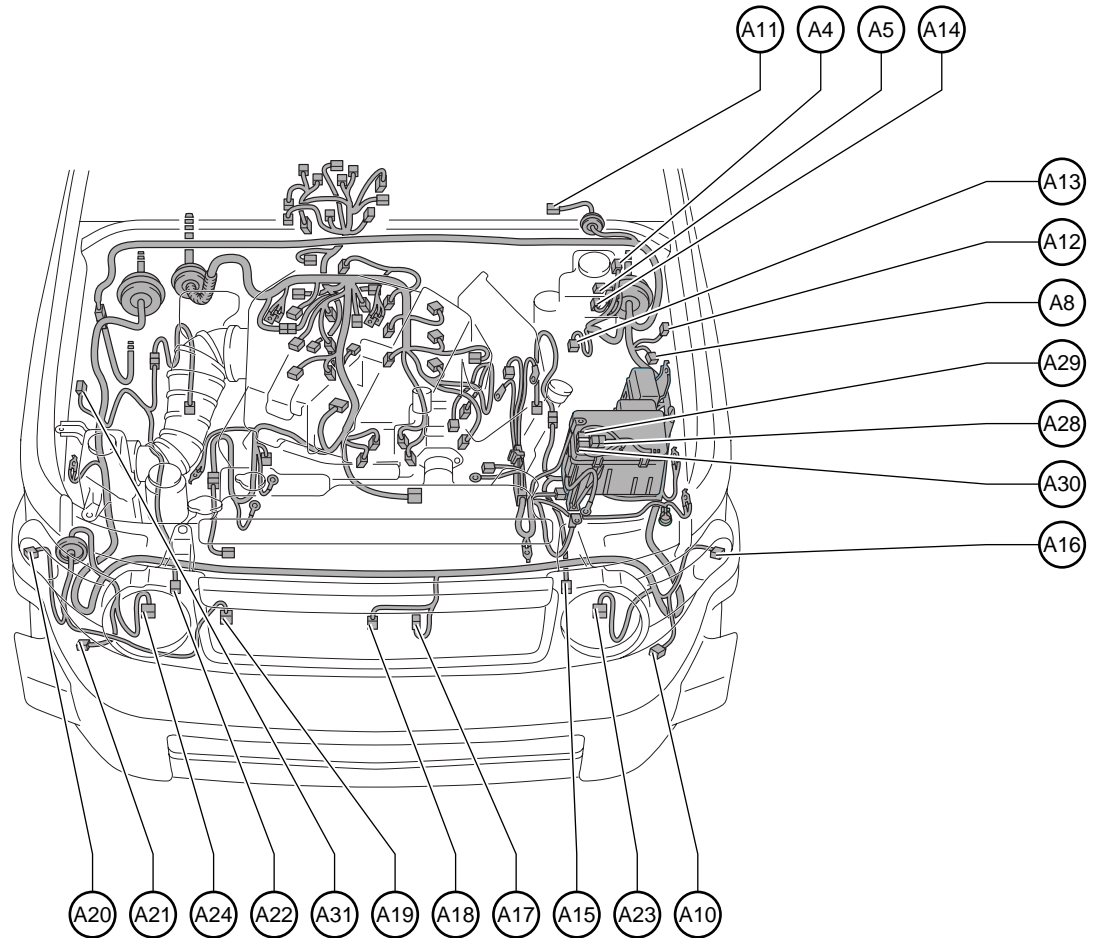

- A 4 Skid Control ECU with Actuator
- A 5 Skid Control ECU with Actuator
- A 8 Option Connector (Driving Lamp)
- A10 Daytime Running Light Resistor
- A11 Windshield Wiper Motor
- A12 Wireless Door Lock Buzzer
- A13 Fuel Pump Resistor
- A14 Brake Fluid Level Warning SW
- A15 Airbag Sensor (Front LH)
- A16 Turn Signal and Parking Lamp (Front LH)
- A17 Horn

- A18 Ambient Temp. Sensor
- A19 Pressure SW
- A20 Turn Signal and Parking Lamp (Front RH)
- A21 Windshield Washer Motor
- A22 Airbag Sensor (Front RH)
- A23 Headlamp (LH)
- A24 Headlamp (RH)
- A28 Junction Connector
- A29 Junction Connector
- A30 Junction Connector
- A31 Option Connector (Horn)

Position of Parts in Engine Compartment

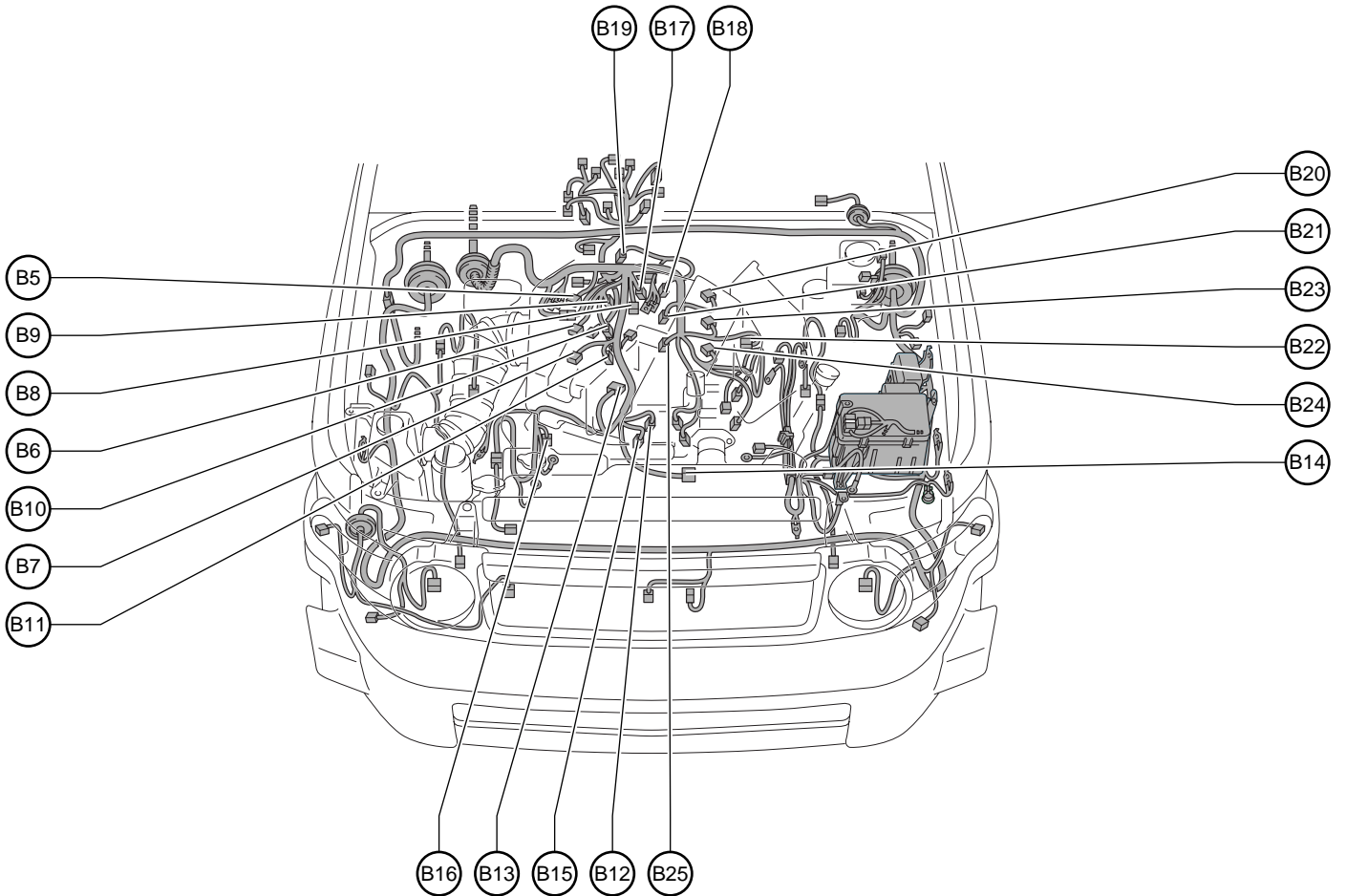

- | | |
|---|-------------------------------------|
| B 5 Ignition Coil (No.5) | B 16 Power Steering Oil Pressure SW |
| B 6 Ignition Coil (No.3) | B 17 VSV (ACIS) |
| B 7 Ignition Coil (No.1) | B 18 Fuel Injector (No.6) |
| B 8 Noise Filter (Ignition) | B 19 Engine Coolant Temp. Sensor |
| B 9 Fuel Injector (No.5) | B 20 Ignition Coil (No.6) |
| B 10 Fuel Injector (No.3) | B 21 Fuel Injector (No.4) |
| B 11 Fuel Injector (No.1) | B 22 VSV (Purge) |
| B 12 Camshaft Timing Oil Control Valve (RH) | B 23 Ignition Coil (No.4) |
| B 13 Mass Air Flow Meter | B 24 Ignition Coil (No.2) |
| B 14 Throttle Body Assembly | B 25 Fuel Injector (No.2) |
| B 15 VVT Sensor (Bank 1) | |

G ELECTRICAL WIRING ROUTING

Position of Parts in Engine Compartment

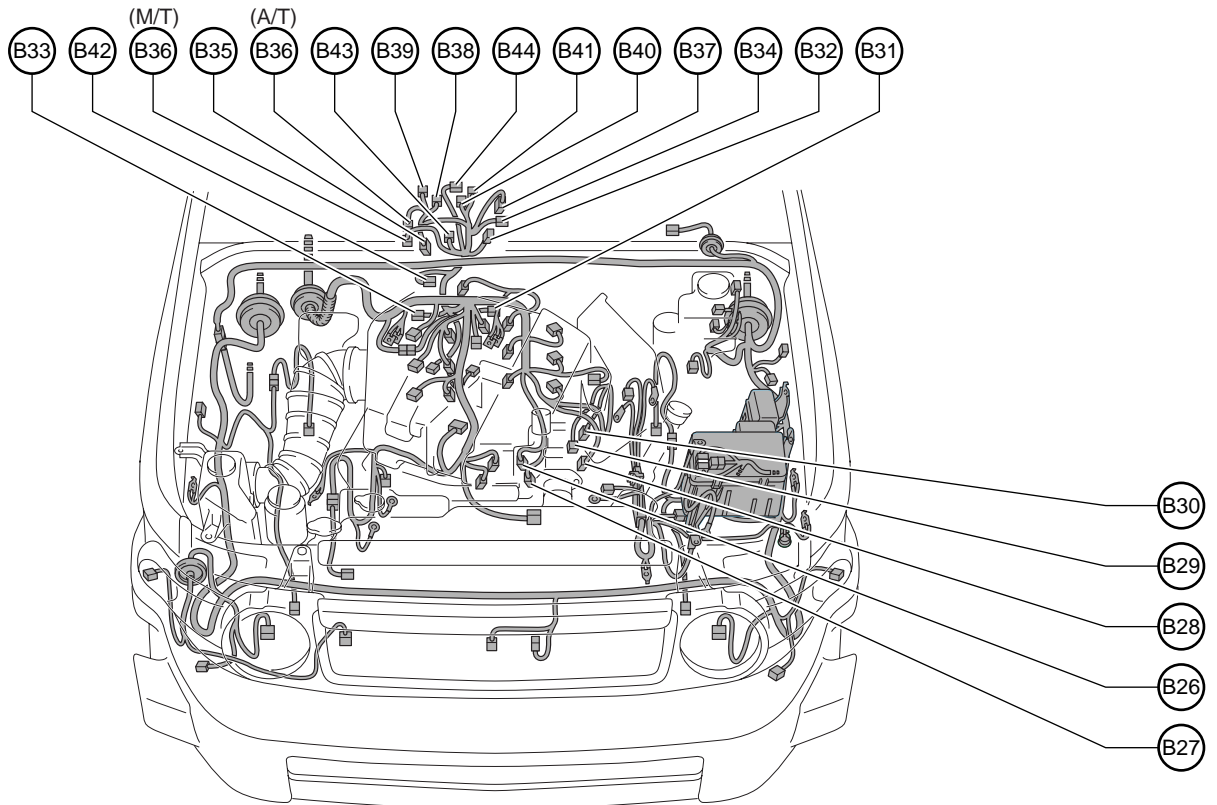

B26 Camshaft Timing Oil Control Valve (LH)

B27 VVT Sensor (Bank 2)

B28 Engine Oil Pressure SW

B29 Crankshaft Position Sensor

B30 A/C Compressor

B31 Air Fuel Ratio Sensor (Bank 2 Sensor 1)

B32 Transmission Revolution Sensor (Turbine)

B33 Air Fuel Ratio Sensor (Bank 1 Sensor 1)

B34 Heated Oxygen Sensor (Bank 2 Sensor 2)

B35 Park/Neutral Position SW

B36 Heated Oxygen Sensor (Bank 1 Sensor 2)

B37 Electronically Controlled Transmission Solenoid

B38 Transmission Revolution Sensor
(Electronically Controlled Transmission)

B39 Transfer Indicator SW (4WD Position)

B40 Transfer Indicator SW (L4 Position)

B41 Transfer Indicator SW (Neutral Position)

B42 Back-Up Lamp SW

B43 Transfer Indicator SW (Center Diff.)

B44 Vehicle Speed Sensor (Combination Meter)

Position of Parts in Engine Compartment

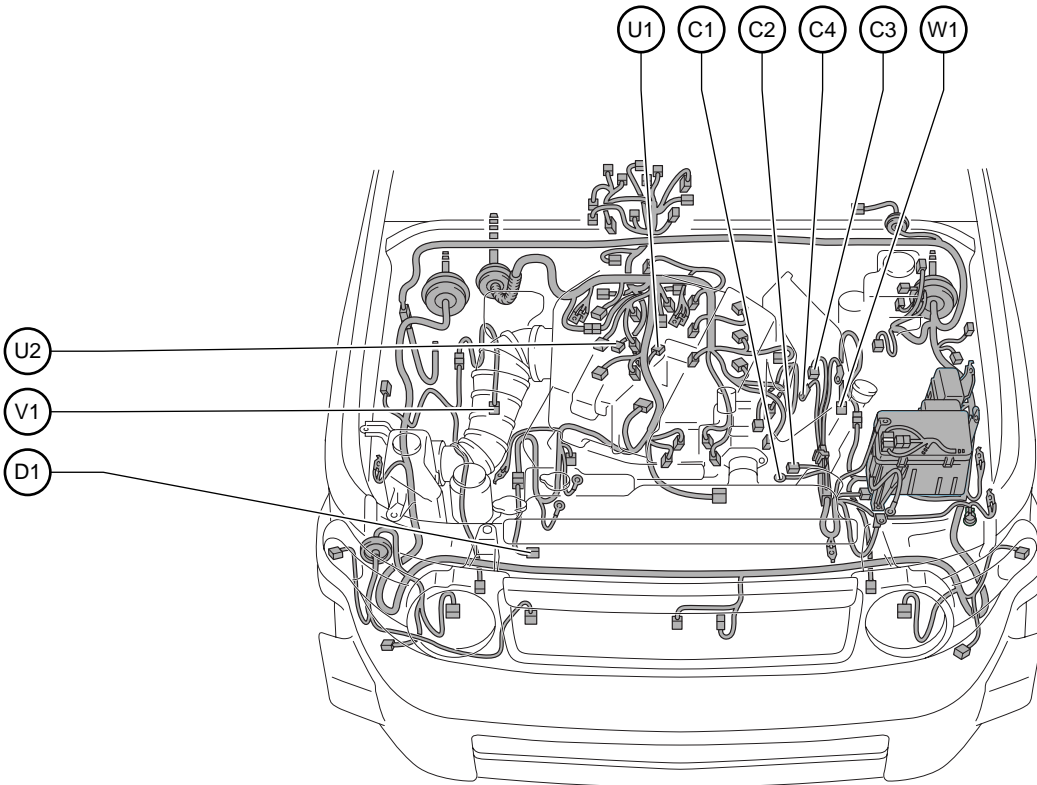

C 1 Generator
 C 2 Generator
 C 3 Starter
 C 4 Starter

D 1 ADD Actuator Assembly

U 1 Knock Control Sensor (Bank 2)
 U 2 Knock Control Sensor (Bank 1)

V 1 Speed Sensor (Front RH)

W 1 Speed Sensor (Front LH)

G ELECTRICAL WIRING ROUTING

Position of Parts in Instrument Panel

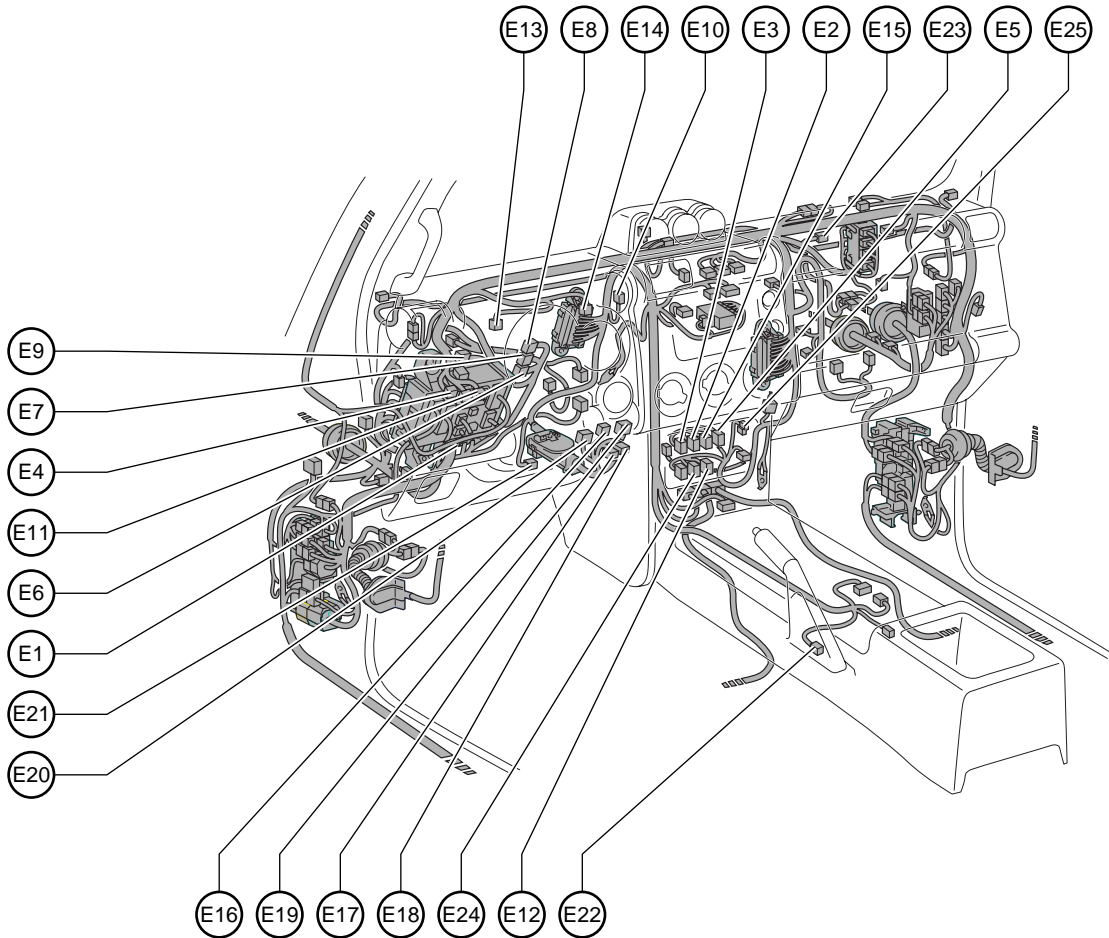

- | | |
|------------------------------------|--|
| E 1 Data Link Connector 3 | E 14 Combination Meter |
| E 2 Diff. Lock SW | E 15 Traction Control SW (Active TRAC) |
| E 3 Traction Control SW (Auto LSD) | E 16 Steering Sensor |
| E 4 Light Control Rheostat | E 17 Spiral Cable |
| E 5 Woofer Speaker SW | E 18 Airbag Squib (Steering Wheel Pad) |
| E 6 Body ECU | E 19 Windshield Wiper SW Assembly |
| E 7 Body ECU | E 20 Headlamp Dimmer SW Assembly |
| E 8 Body ECU | E 21 Unlock Warning SW |
| E 9 Turn Signal Flasher | E 22 Parking Brake SW |
| E 10 Clearance Warning Buzzer | E 23 Door Control Receiver |
| E 11 Clutch Start Cancel SW | E 24 Main SW |
| E 12 Back Sonar SW | E 25 Power Outlet Socket |
| E 13 Combination Meter | |

Position of Parts in Instrument Panel

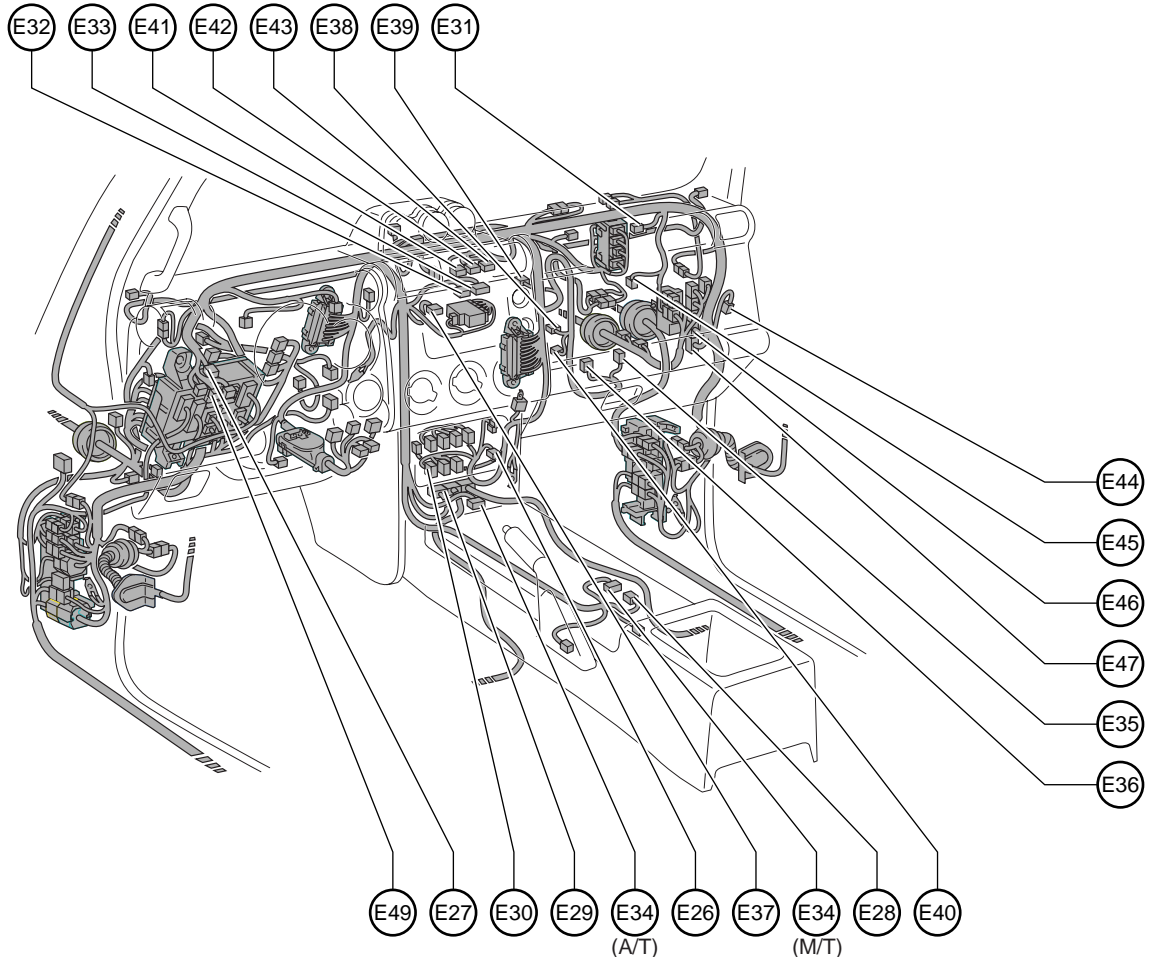

E26 Stereo Jack Adapter
 E27 Speaker Condenser
 E28 Shift Lock Control ECU
 E29 Airbag Sensor Assembly Center
 E30 Option Connector (Off-road Lamp SW)
 E31 Clearance Warning ECU
 E32 A/C Amplifier
 E33 A/C Amplifier
 E34 Yaw Rate Sensor
 E35 Blower Motor
 E36 Blower Resistor
 E37 Blower SW

E38 Damper Servo Motor (Air Mix)
 E39 Damper Servo Motor (Air Vent Mode)
 E40 A/C Thermistor
 E41 Radio Receiver Assembly
 E42 Radio Receiver Assembly
 E43 Radio Receiver Assembly
 E44 Option Connector (TVIP)
 E45 Damper Servo Motor (Air Inlet)
 E46 Engine Control Module
 E47 Engine Control Module
 E49 Outer Mirror SW

G ELECTRICAL WIRING ROUTING

Position of Parts in Instrument Panel

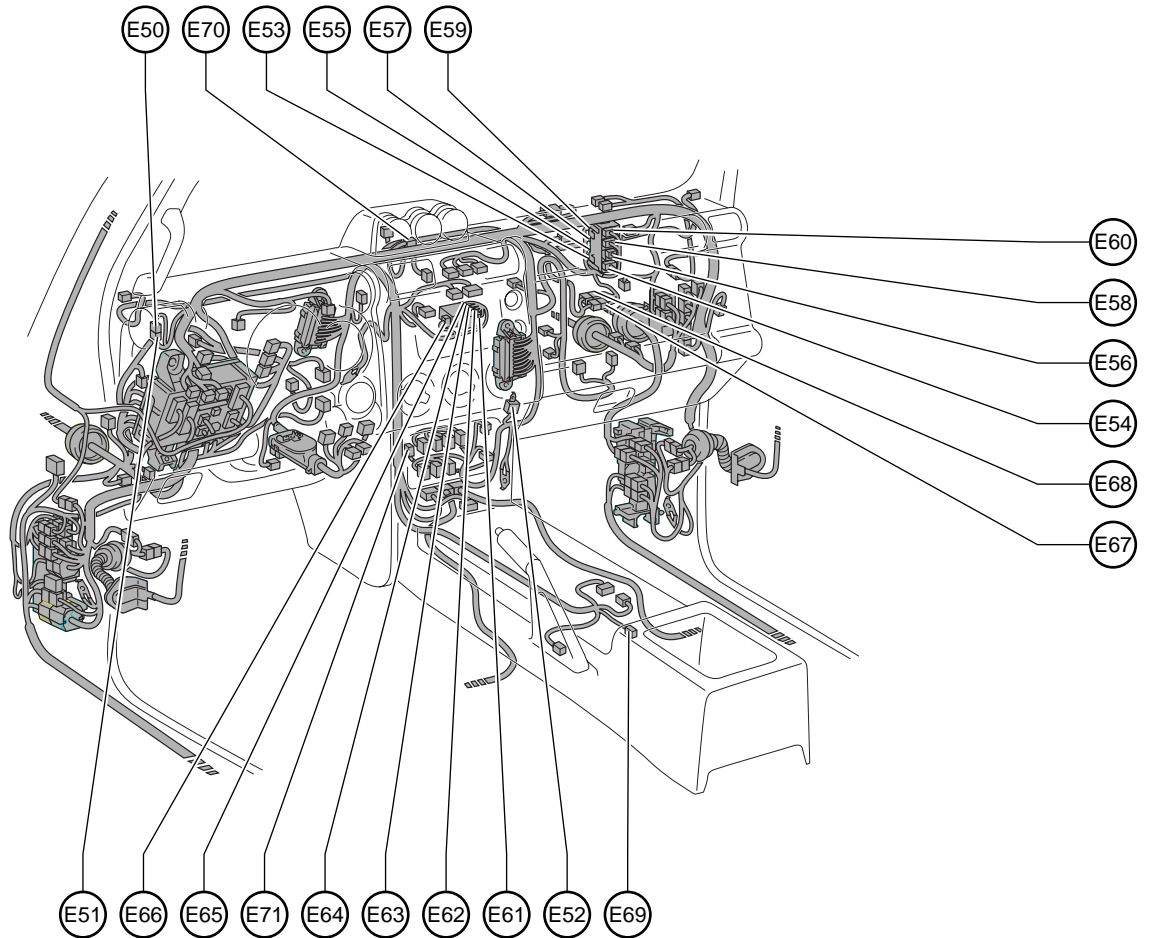

- E 50 Junction Connector
- E 51 Junction Connector
- E 52 Junction Connector
- E 53 Junction Connector
- E 54 Junction Connector
- E 55 Junction Connector
- E 56 Junction Connector
- E 57 Junction Connector
- E 58 Junction Connector
- E 59 Junction Connector
- E 60 Junction Connector

- E 61 Junction Connector
- E 62 Junction Connector
- E 63 Junction Connector
- E 64 Junction Connector
- E 65 Junction Connector
- E 66 Junction Connector
- E 67 Junction Connector
- E 68 Junction Connector
- E 69 A/T Shift Lever Illumination
- E 70 Option Connector (Off-road Lamp Diode)
- E 71 Noise Filter (Stereo Jack Adapter)

Position of Parts in Instrument Panel

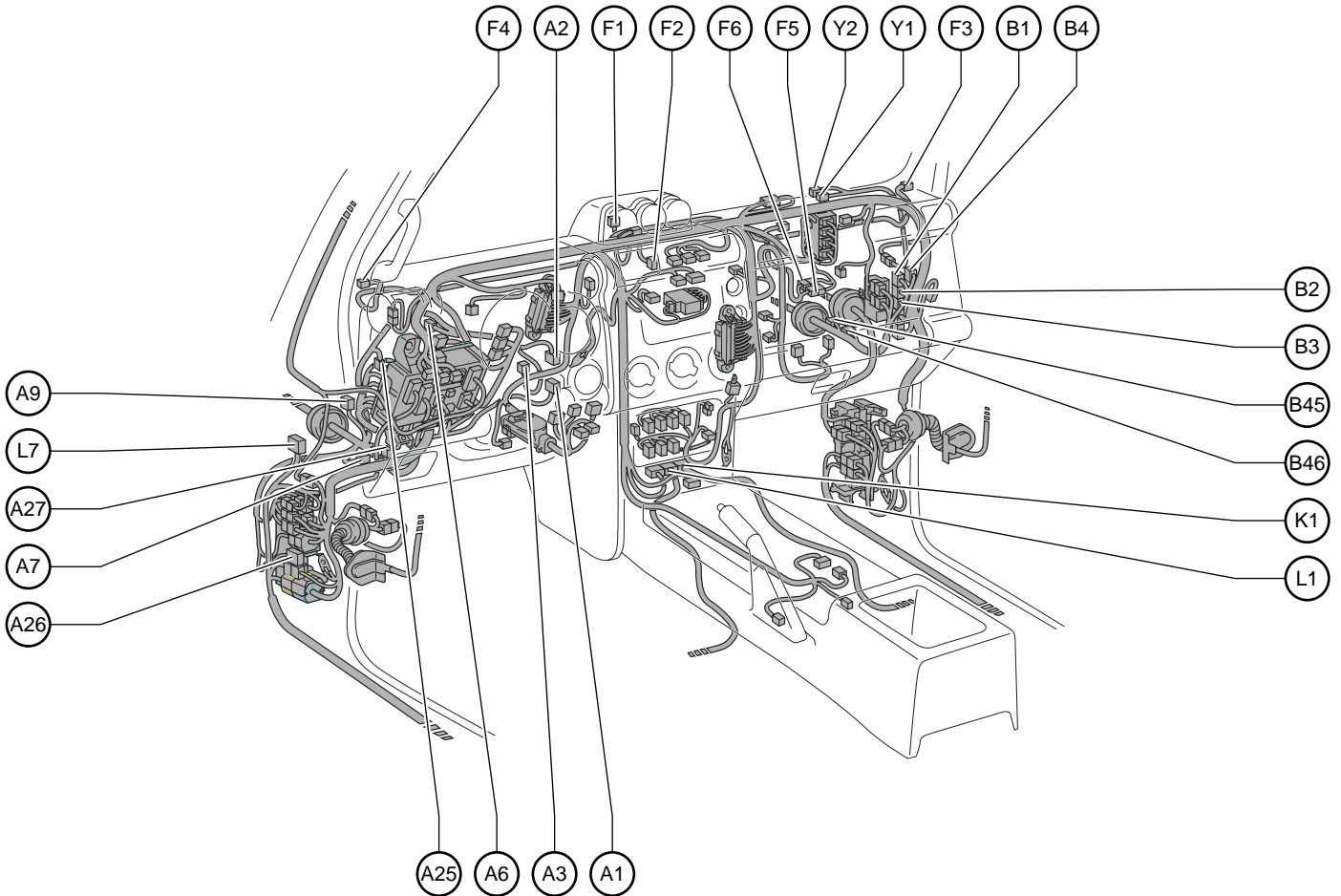

- A 1 Ignition SW
- A 2 Accelerator Position Sensor
- A 3 Stop Lamp SW
- A 6 VSC Warning Buzzer
- A 7 Option Connector (Towing Converter Relay)
- A 9 Clutch Start SW
- A25 Cruise Control Clutch SW
- A26 Option Connector (Driving Lamp SW)
- A27 Junction Connector

- B 1 Engine Control Module
- B 2 Engine Control Module
- B 3 Engine Control Module
- B 4 4WD Control ECU
- B45 Junction Connector
- B46 Junction Connector

- F 1 Accessory Meter
- F 2 Clock
- F 3 Tweeter (Front RH)
- F 4 Tweeter (Front LH)
- F 5 Junction Connector
- F 6 Junction Connector

- K 1 Airbag Sensor Assembly Center

- L 1 Airbag Sensor Assembly Center
- L 7 4WD Control ECU (Rear Diff. Lock)

- Y 1 Airbag Squib (Front Passenger's Airbag Assembly)
- Y 2 Airbag Squib (Front Passenger's Airbag Assembly)

G ELECTRICAL WIRING ROUTING

Position of Parts in Body

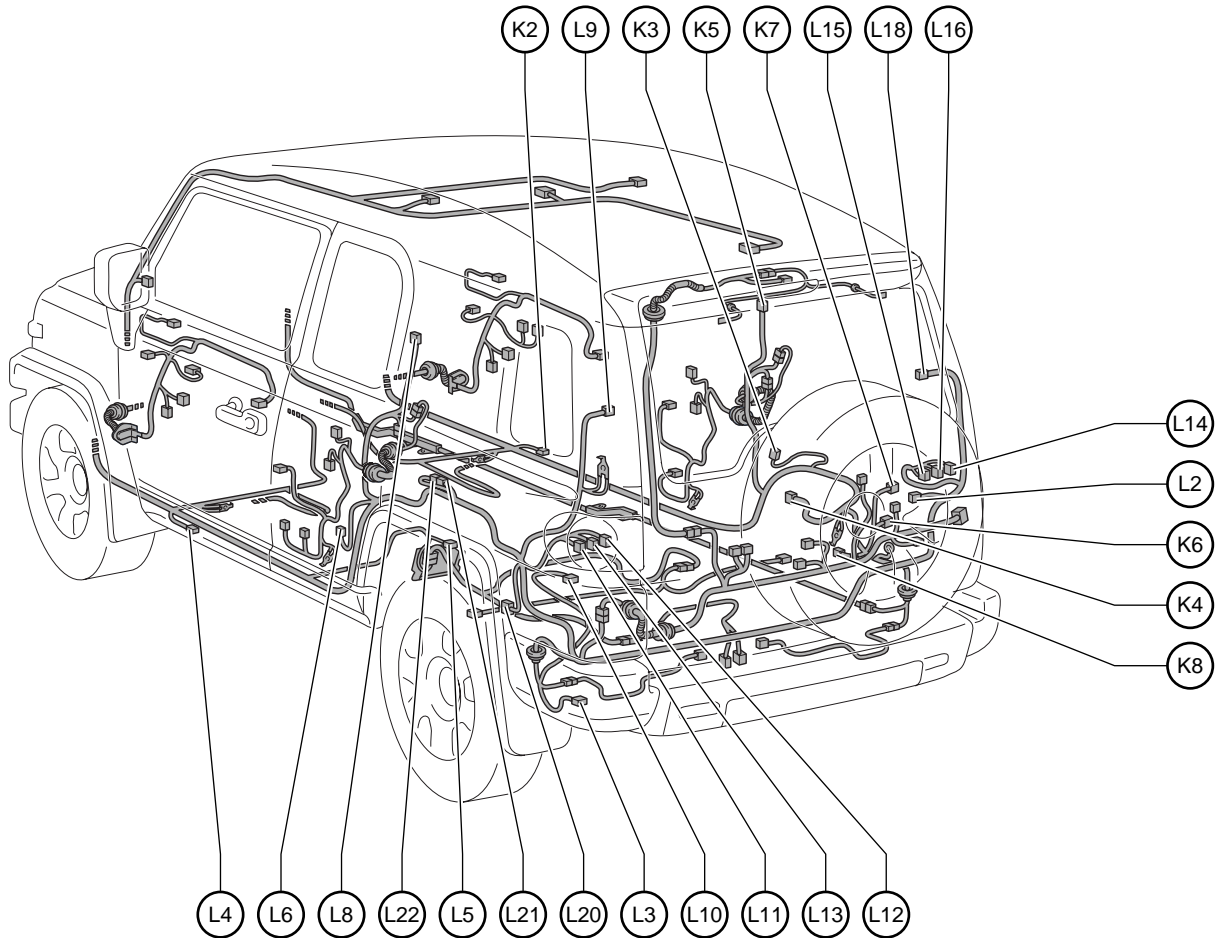

- K 2 Side Airbag Sensor (Front RH)
- K 3 Side Airbag Sensor (Rear RH)
- K 4 Speaker (Woofer w/ Amplifier)
- K 5 Curtain Shield Airbag Squib (RH)
- K 6 Voltage Inverter
- K 7 Voltage Inverter
- K 8 Power Outlet Socket (115V)

- L 2 Door Courtesy SW (Back Door)
- L 3 Option Connector (Trailer Socket)
- L 4 Side Airbag Sensor (Front LH)
- L 5 Fuel Suction Pump and Gage Assembly
- L 6 Side Airbag Sensor (Rear LH)
- L 8 Curtain Shield Airbag Squib (LH)
- L 9 Tweeter (Rear LH)
- L 10 Canister Pump Module
- L 11 Rear Combination Lamp (LH)
- L 12 Rear Combination Lamp (LH)
- L 13 Rear Combination Lamp (LH)
- L 14 Rear Combination Lamp (RH)
- L 15 Rear Combination Lamp (RH)
- L 16 Rear Combination Lamp (RH)
- L 18 Tweeter (Rear RH)
- L 20 Junction Connector
- L 21 Junction Connector
- L 22 Junction Connector

Position of Parts in Body

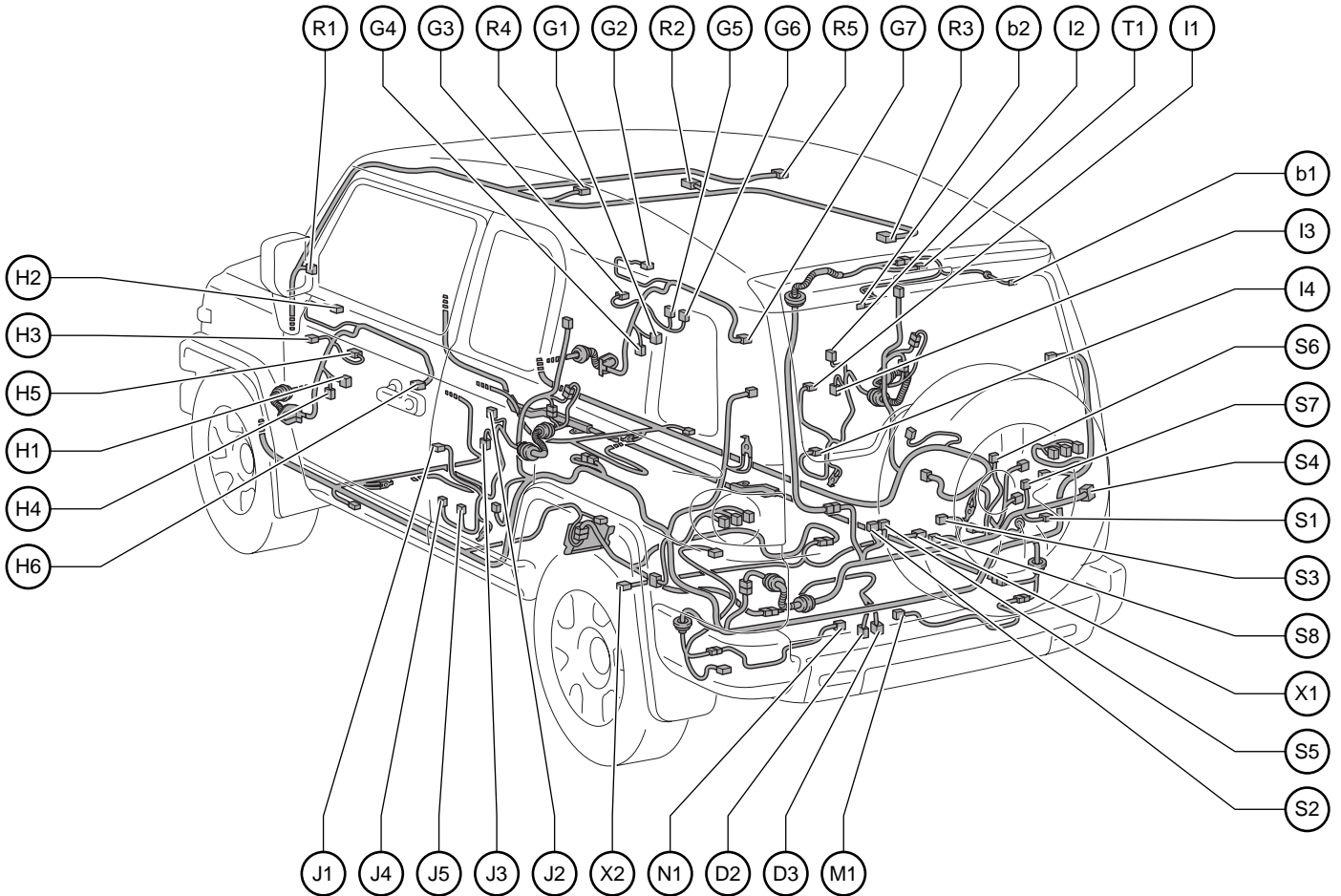

D 2 Transfer Indicator SW (Rear Diff.)
D 3 Diff. Lock Shift Actuator Assembly

G 1 Junction Connector
G 2 Outer Rear View Mirror (RH)
G 3 Power Window Regulator Motor (Front RH)
G 4 Speaker (Front RH)
G 5 Door Lock Control SW
G 6 Power Window SW (Front RH)
G 7 Door Lock Assembly (Front RH)

H 1 Junction Connector
H 2 Outer Rear View Mirror (LH)
H 3 Power Window Regulator Motor (Front LH)
H 4 Speaker (Front LH)
H 5 Power Window Master SW
H 6 Door Lock Assembly (Front LH)

I 1 Door Courtesy SW (Front RH)
I 2 Door Courtesy SW (Rear RH Upper Side)
I 3 Door Courtesy SW (Rear RH Lower Side)
I 4 Pretensioner (RH)

J 1 Door Courtesy SW (Front LH)
J 2 Door Courtesy SW (Rear LH Upper Side)
J 3 Door Courtesy SW (Rear LH Lower Side)
J 4 Pretensioner (LH)
J 5 Front Seat Outer Belt (LH)

M 1 Ultrasonic Sensor (Rear Center RH)

N 1 Ultrasonic Sensor (Rear Center LH)

R 1 Option Connector (EC Mirror and Off-road Lamp)
R 2 Room Lamp (Front)
R 3 Room Lamp (Rear)
R 4 Speaker (Roof LH)
R 5 Speaker (Roof RH)

S 1 License Plate Lamp
S 2 Door ECU (Back)
S 3 Rear Wiper Motor Assembly
S 4 Back Door Lock Assembly
S 5 Door ECU (Back)
S 6 Back Window Lock Assembly
S 7 Back Door Lock Cylinder Assembly
S 8 Diode (Back Door)

T 1 Center Stop Lamp

X 1 Speed Sensor (Rear RH)
X 2 Speed Sensor (Rear LH)

b 1 Rear Window Defogger
b 2 Rear Window Defogger

G ELECTRICAL WIRING ROUTING

Position of Parts in Seat

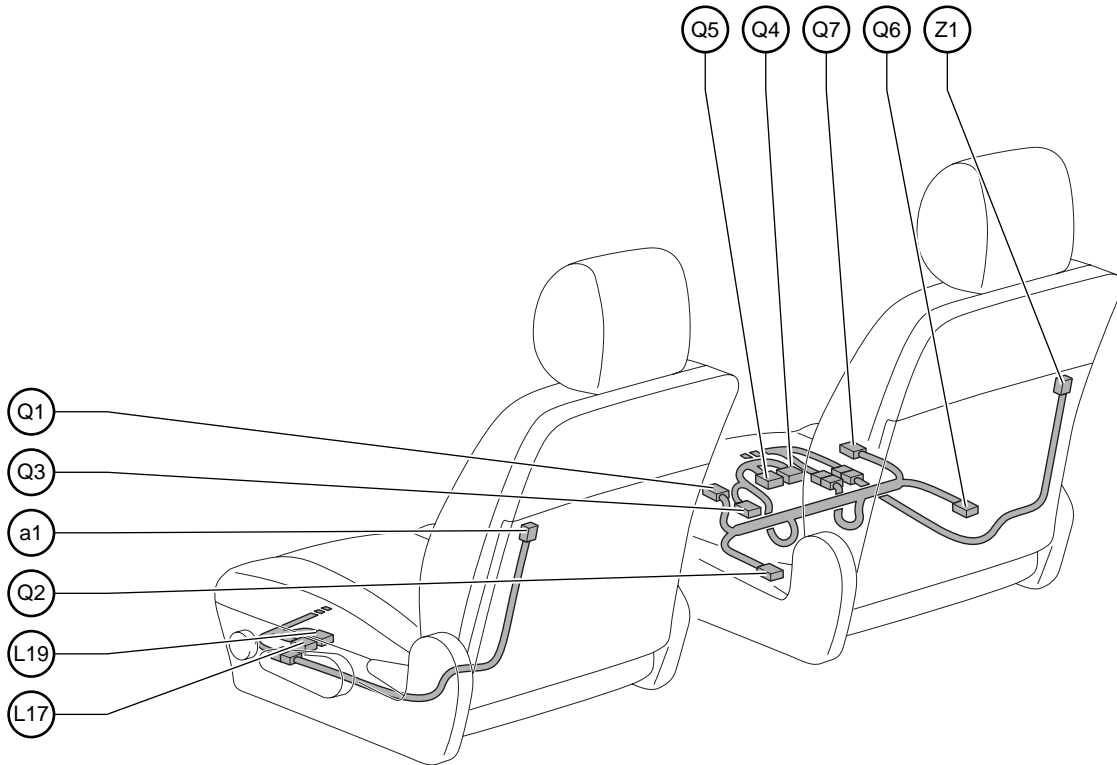

L 17 Front Seat Inner Belt (LH)
L 19 Front Seat Inner Belt (LH)

Z 1 Side Airbag Squib (RH)

a 1 Side Airbag Squib (LH)

Q 1 Occupant Classification Sensor (Front LH)
Q 2 Occupant Classification Sensor (Rear LH)
Q 3 Front Seat Inner Belt (RH)
Q 4 Occupant Classification ECU
Q 5 Occupant Classification ECU
Q 6 Occupant Classification Sensor (Rear RH)
Q 7 Occupant Classification Sensor (Front RH)

G ELECTRICAL WIRING ROUTING

□ : Location of Connector Joining Wire Harness and Wire Harness

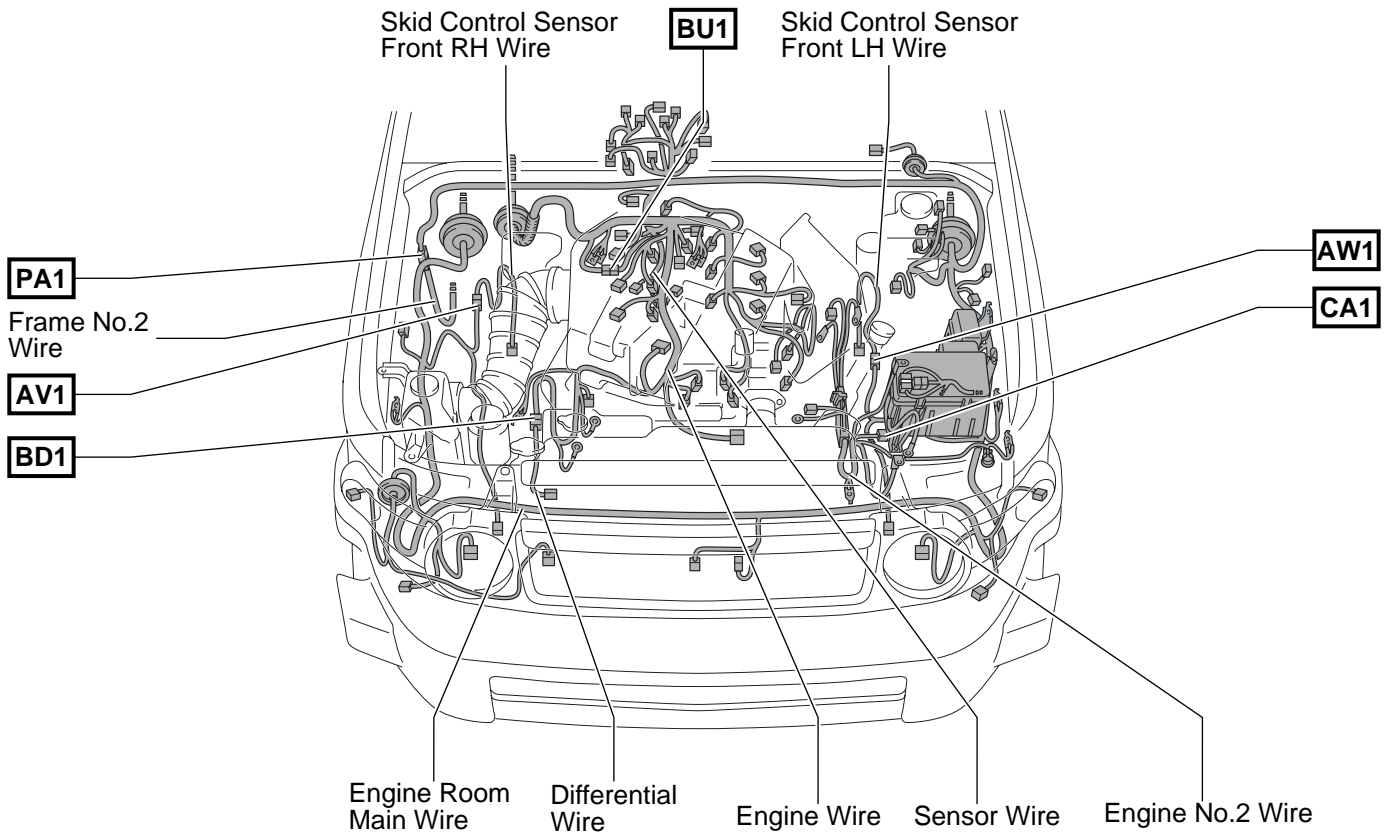

▽ : Location of Ground Points

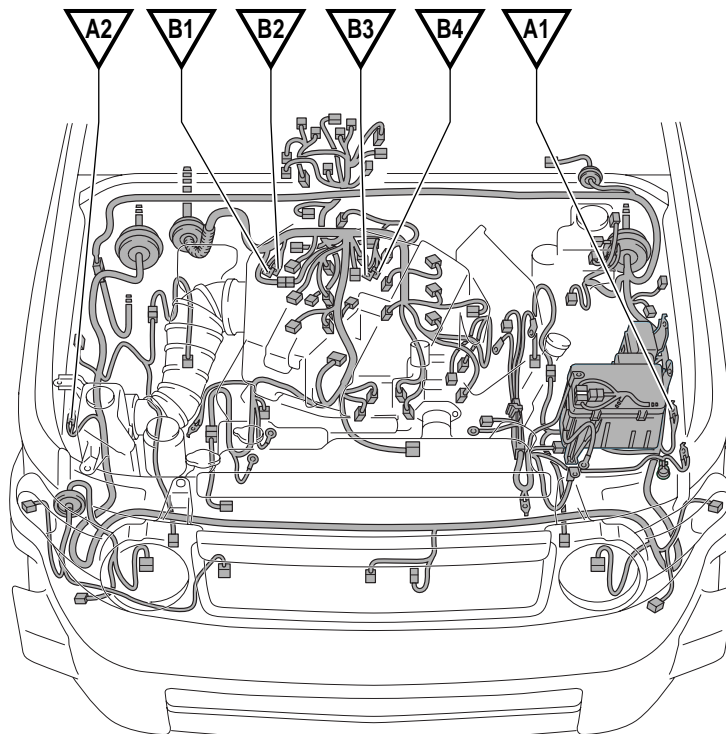

□ : Location of Connector Joining Wire Harness and Wire Harness

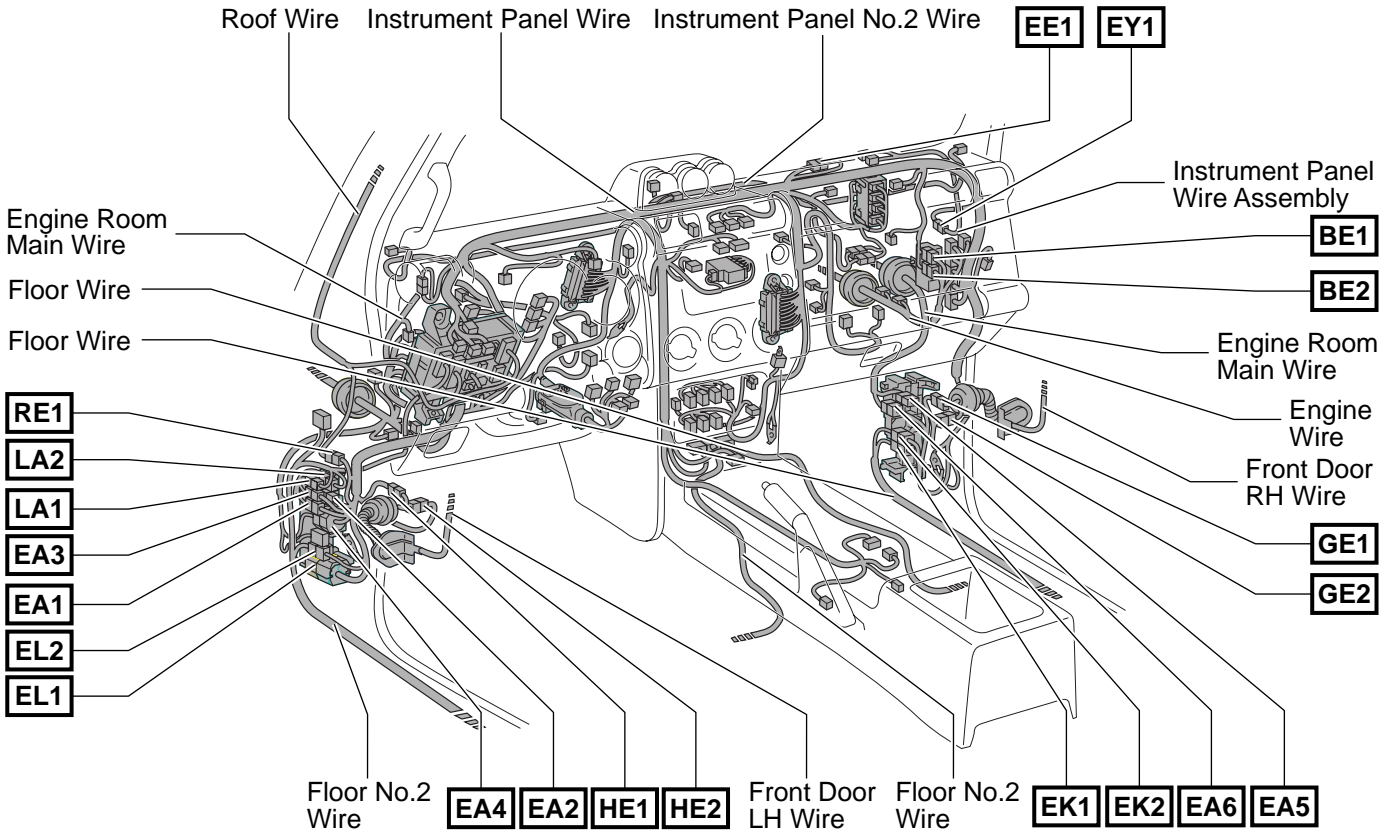

▽ : Location of Ground Points

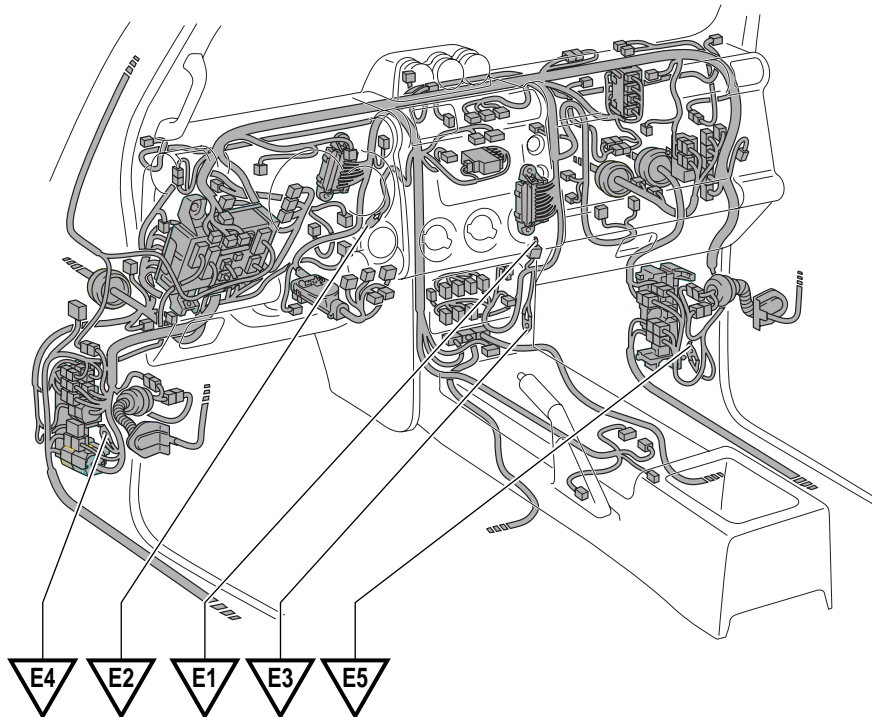

G ELECTRICAL WIRING ROUTING

□ : Location of Connector Joining Wire Harness and Wire Harness

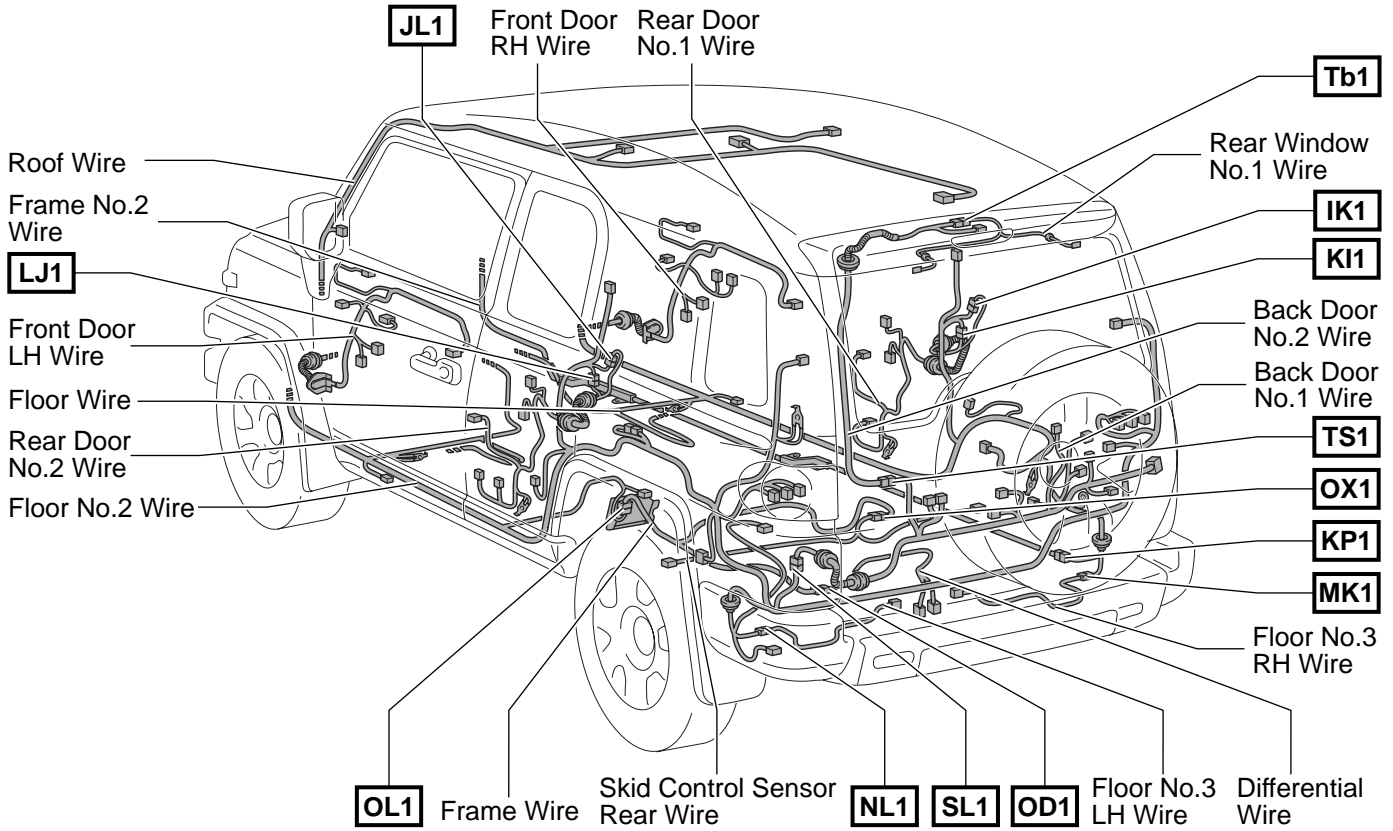

▽ : Location of Ground Points

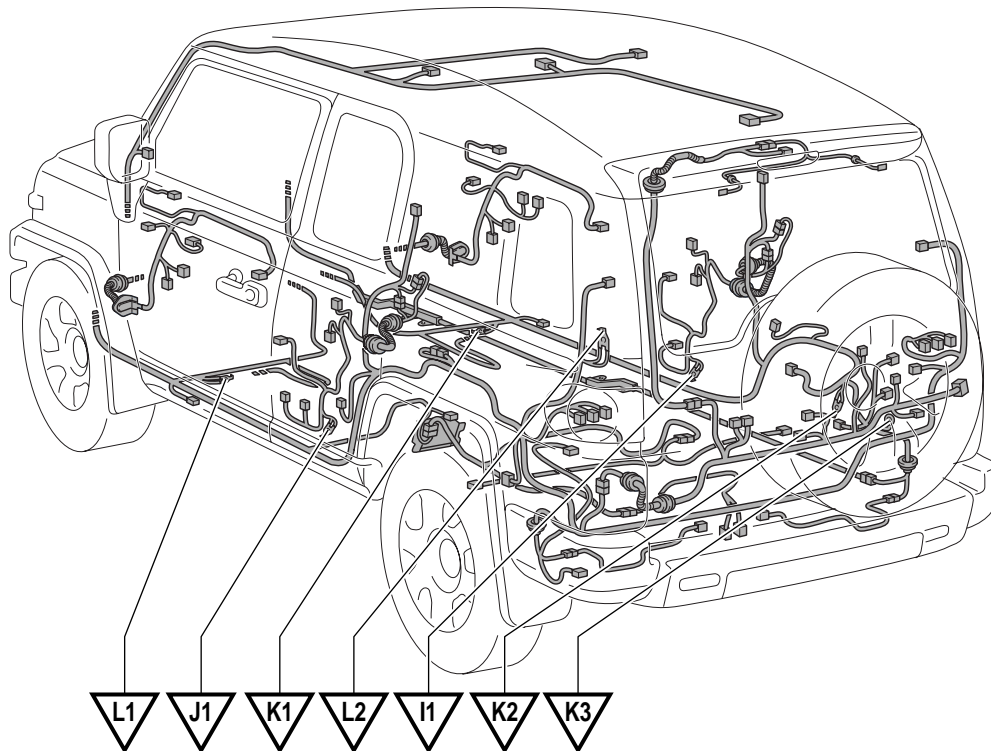

□ : Location of Connector Joining Wire Harness and Wire Harness

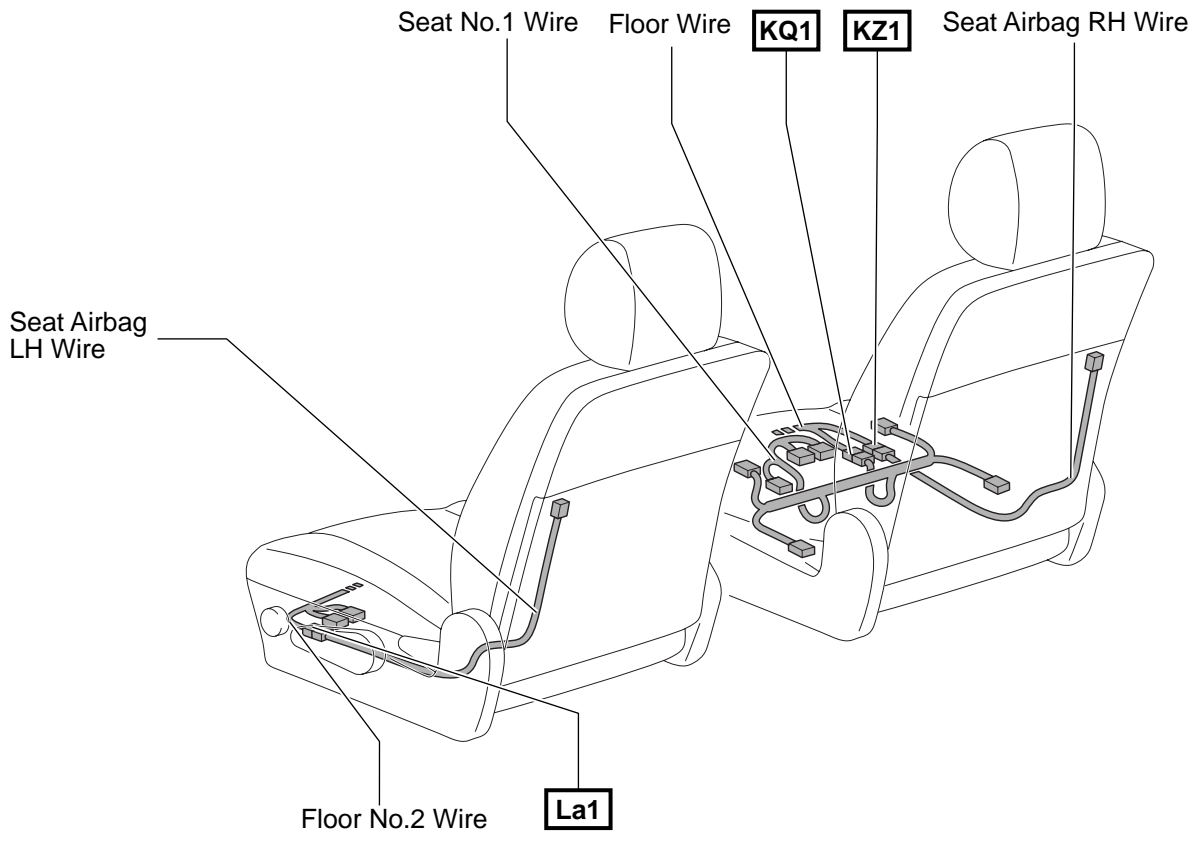

2007 FJ CRUISER ELECTRICAL WIRING DIAGRAM SYSTEM CIRCUITS

	Page
ABS	186
Accessory Meter	230
Air Conditioning	250
Audio System	236
Auto LSD	186
Back-Up Light	126
Charging	68
Clock	228
Combination Meter	242
Cruise Control	176
Data Link Connector 3	86
Door Lock Control	150
Electric Tension Reducer	222
Electronically Controlled Transmission and A/T Indicator	166
Engine Control	70
Front Wiper and Washer	138
Headlight	94
Horn	220
Ignition	64
Illumination	118
Interior Light	108
Key Reminder	128
Light Auto Turn Off System	100
Multiplex Communication System (BEAN)	90
Multiplex Communication System (CAN)	92
Power Outlet (115V)	214
Power Outlet (12V)	218
Power Source	56
Power Window	146
Rear Differential Lock	200
Rear Window Defogger	224
Rear Wiper and Washer	142
Remote Control Mirror	212
Seat Belt Warning	130
Shift Lock	210
SRS	203
Starting	60
Stop Light	124
Taillight	118
TOYOTA Parking Assist (Clearance Sonar)	234
TRAC	186
Turn Signal and Hazard Warning Light	104
VSC	186
Wireless Door Lock Control	158
4WD	196

Power Source

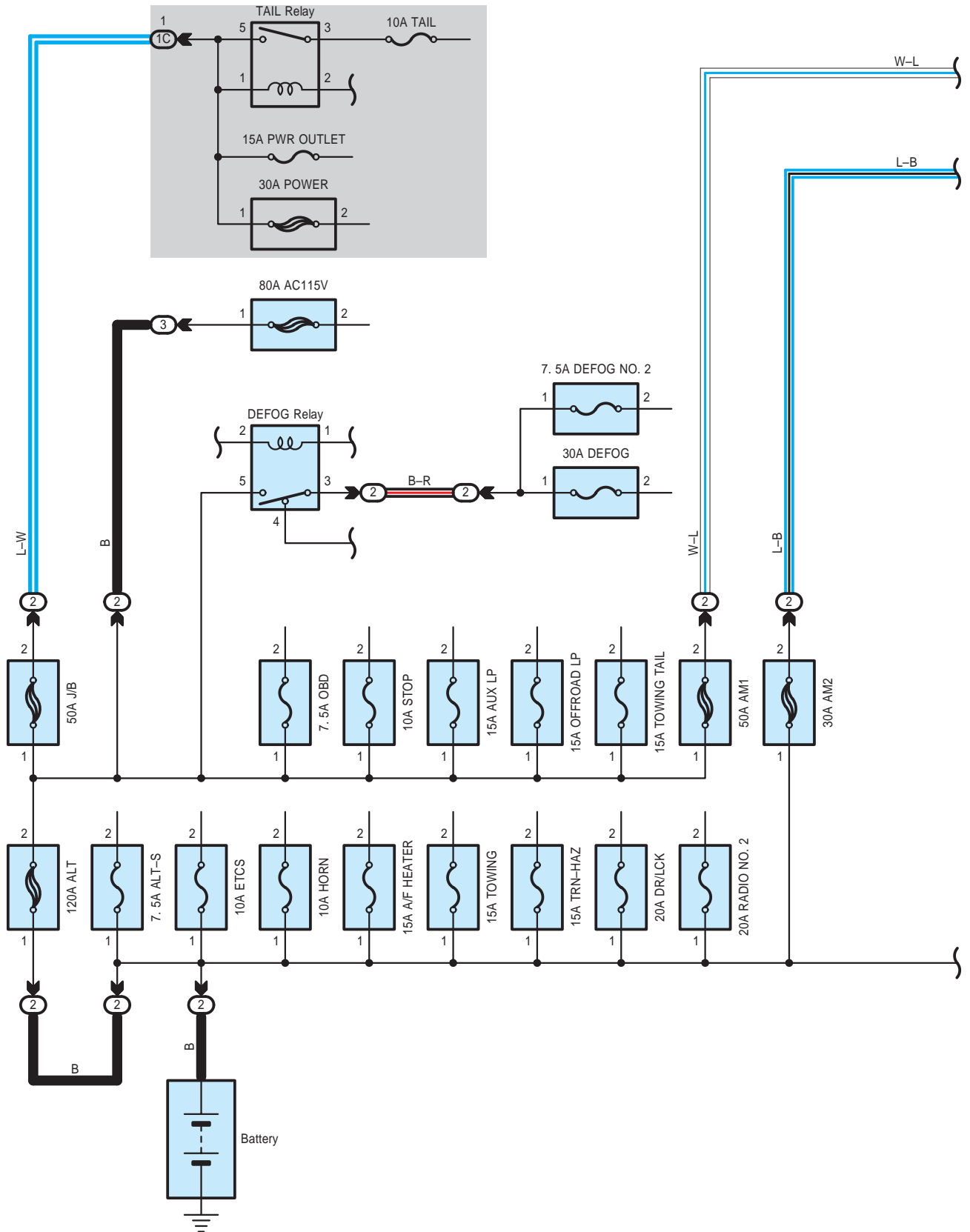

* 1 : w/ Daytime Running Right
 * 2 : w/o Daytime Running Right

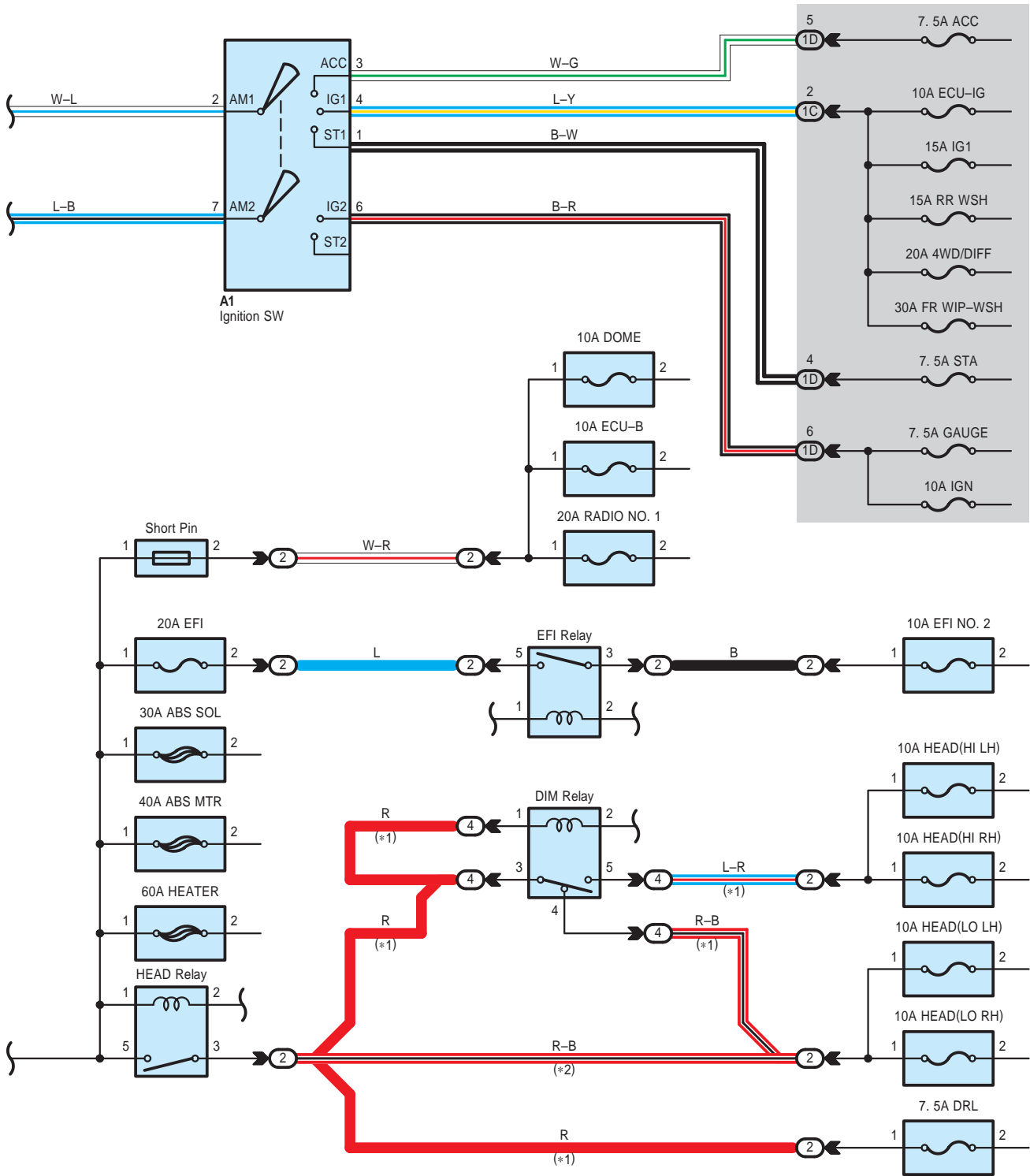

Power Source

: Parts Location

Code	See Page	Code	See Page	Code	See Page
A1	45				

: Relay Blocks

Code	See Page	Relay Blocks (Relay Block Location)
2	22	Engine Room R/B No.2 (Engine Compartment Left)
3	23	Engine Room R/B No.3 (Engine Compartment Left)
4	23	Engine Room R/B No.4 (Engine Compartment Left)

: Junction Block and Wire Harness Connector

Code	See Page	Junction Block and Wire Harness (Connector Location)
1C	24	Engine Room Main Wire and Driver Side J/B (Lower Finish Panel)
1D		

Starting

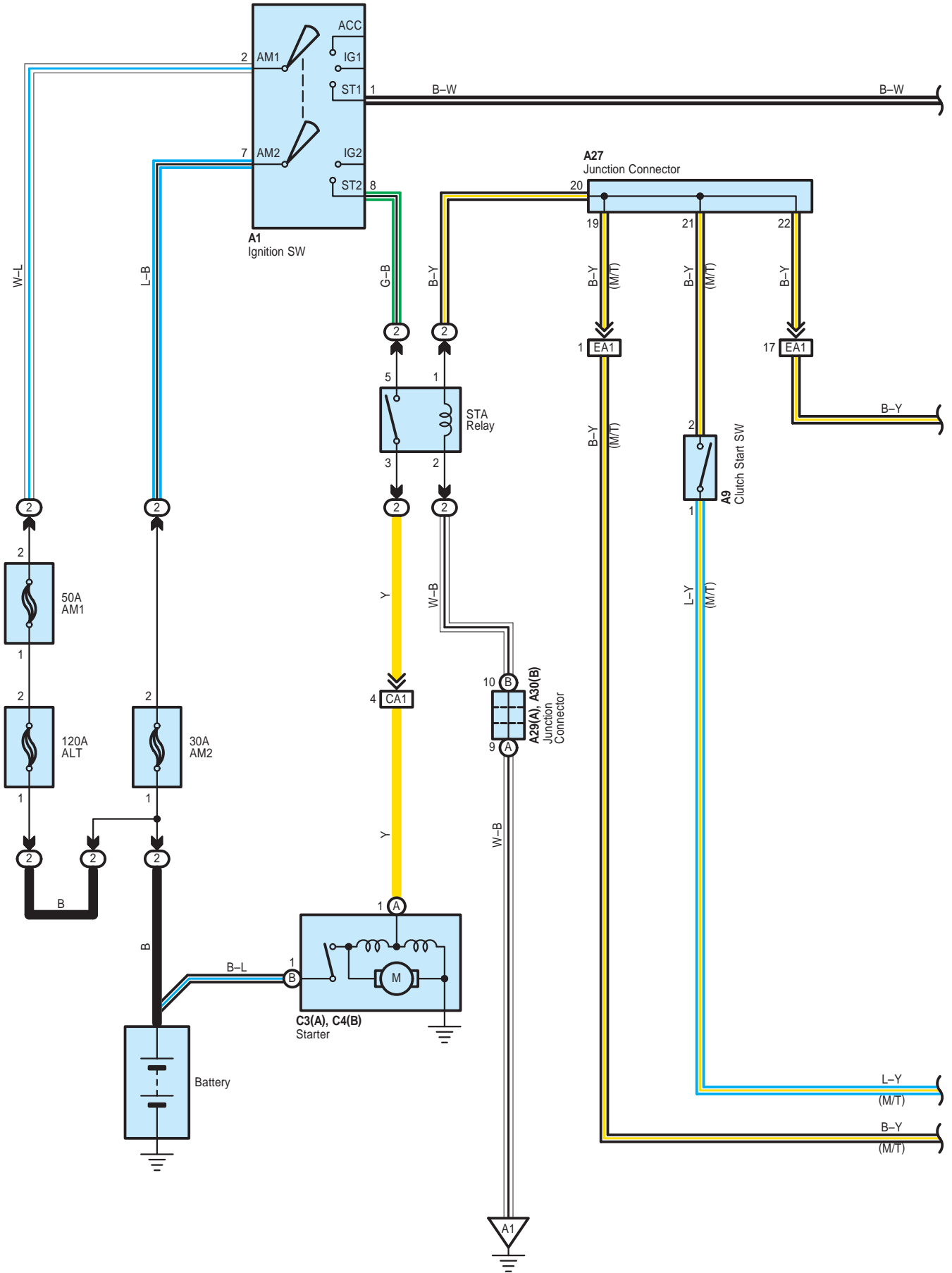

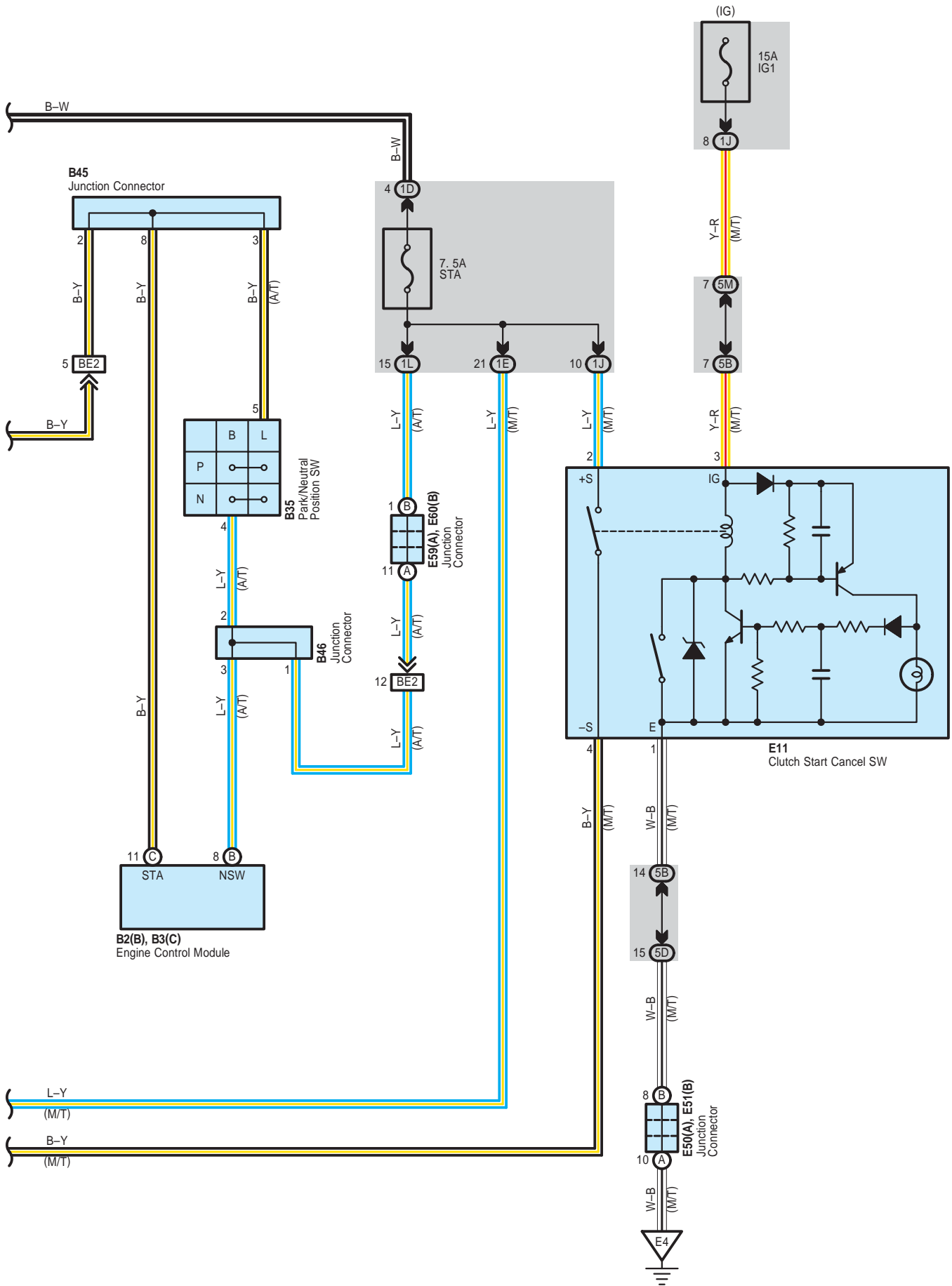

Starting

: Parts Location

Code	See Page	Code	See Page	Code	See Page
A1	45	B3 C	45	E11	42
A9	45	B35	40	E50 A	44
A27	45	B45	45	E51 B	44
A29 A	38	B46	45	E59 A	44
A30 B	38	C3 A	41	E60 B	44
B2 B	45	C4 B	41		

: Relay Blocks

Code	See Page	Relay Blocks (Relay Block Location)
2	22	Engine Room R/B No.2 (Engine Compartment Left)

: Junction Block and Wire Harness Connector

Code	See Page	Junction Block and Wire Harness (Connector Location)
1D 1E	24	Engine Room Main Wire and Driver Side J/B (Lower Finish Panel)
1J 1L	25	Instrument Panel Wire and Driver Side J/B (Lower Finish Panel)
5B 5D 5M	28	Instrument Panel Wire and Center J/B LH (Instrument Panel LH)

: Connector Joining Wire Harness and Wire Harness

Code	See Page	Joining Wire Harness and Wire Harness (Connector Location)
BE2	51	Engine Wire and Instrument Panel Wire (Upper the Glove Box)
CA1	50	Engine No.2 Wire and Engine Room Main Wire (Near the Engine Room R/B No.2)
EA1	51	Instrument Panel Wire and Engine Room Main Wire (Left Kick Panel)

: Ground Points

Code	See Page	Ground Points Location
A1	50	Left Fender Apron
E4	51	Left Kick Panel

Ignition

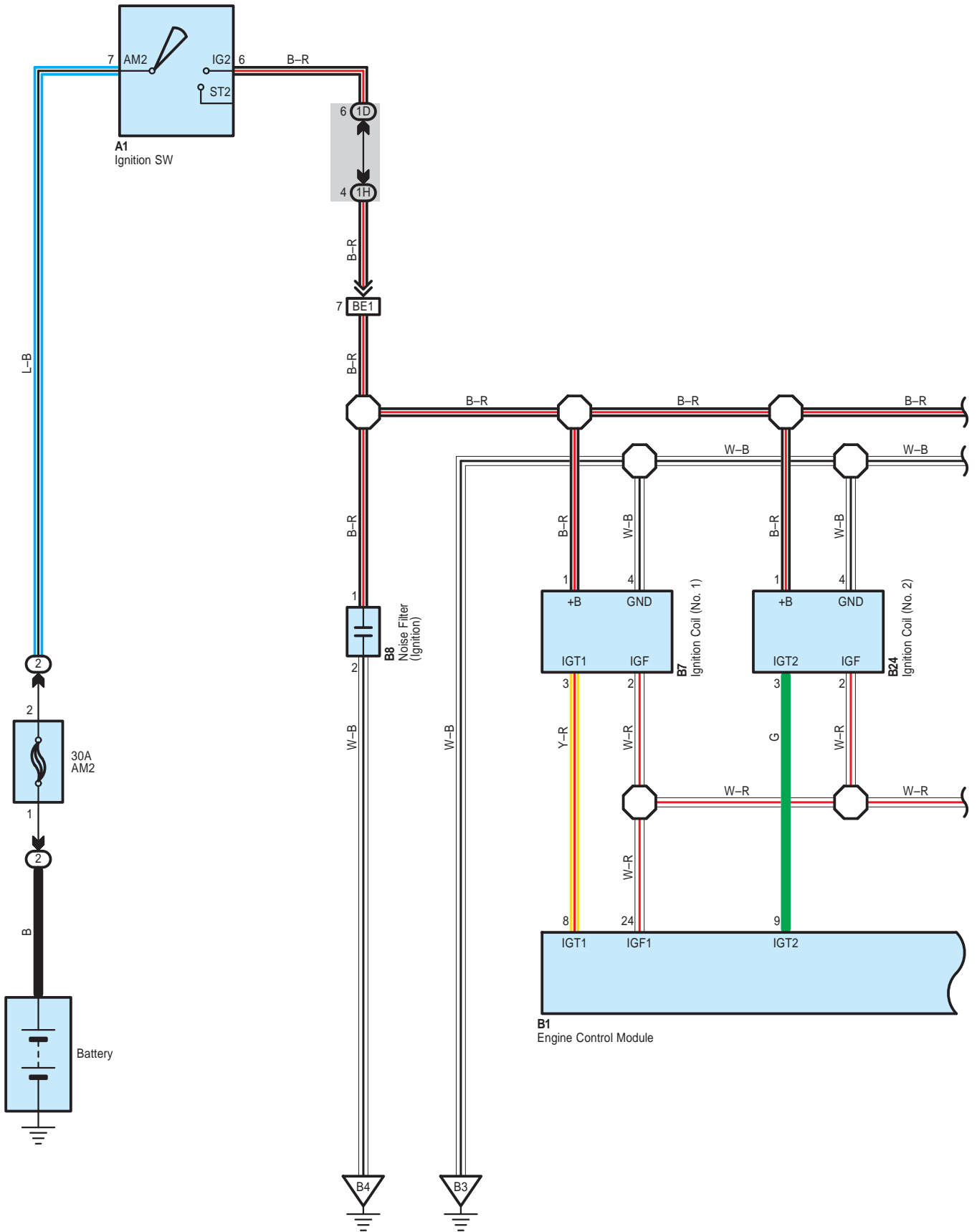

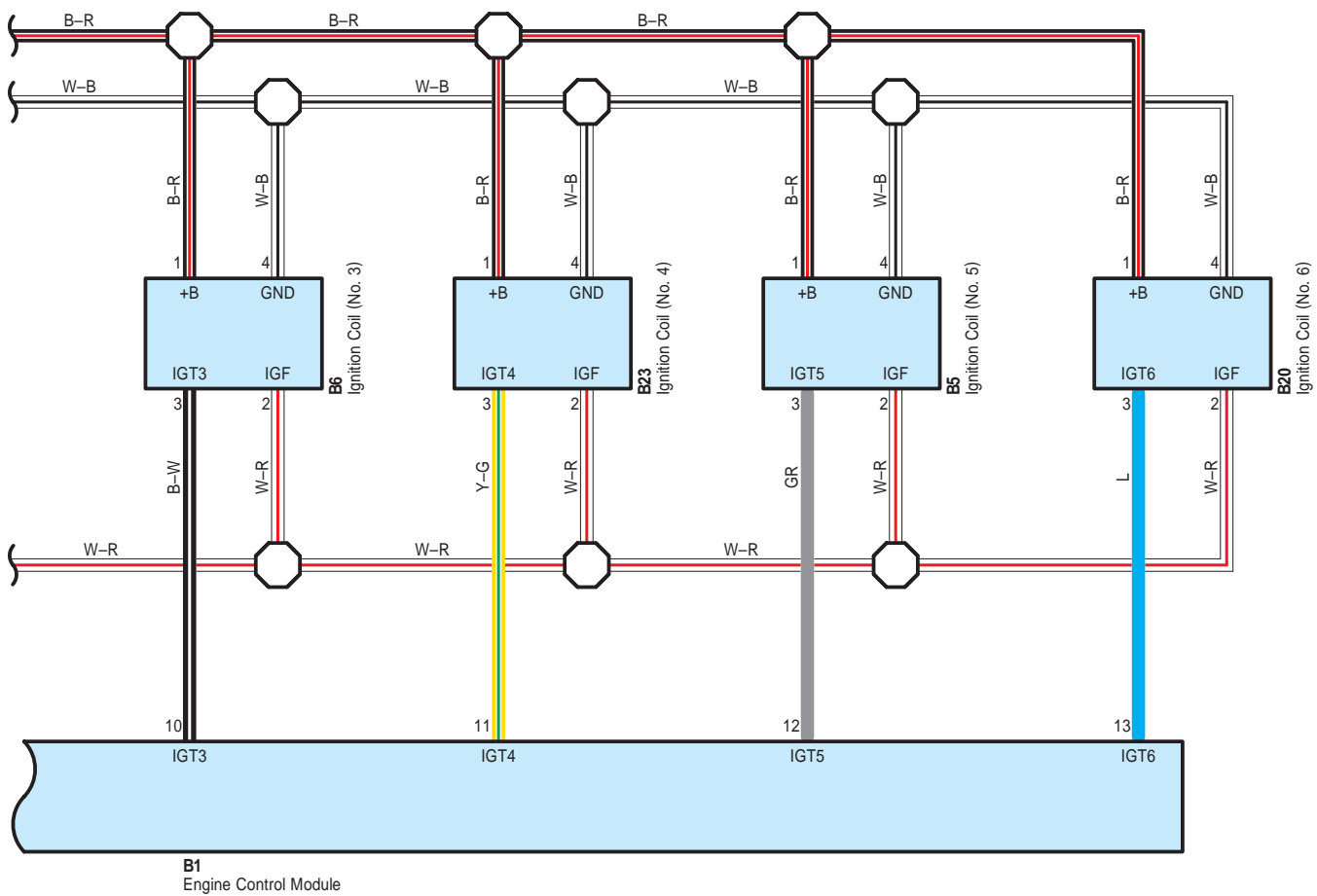

Ignition

: Parts Location

Code	See Page	Code	See Page	Code	See Page
A1	45	B6	39	B20	39
B1	45	B7	39	B23	39
B5	39	B8	39	B24	39

: Relay Blocks

Code	See Page	Relay Blocks (Relay Block Location)
2	22	Engine Room R/B No.2 (Engine Compartment Left)

: Junction Block and Wire Harness Connector

Code	See Page	Junction Block and Wire Harness (Connector Location)
1D	24	Engine Room Main Wire and Driver Side J/B (Lower Finish Panel)
1H	25	Instrument Panel Wire and Driver Side J/B (Lower Finish Panel)

: Connector Joining Wire Harness and Wire Harness

Code	See Page	Joining Wire Harness and Wire Harness (Connector Location)
BE1	51	Engine Wire and Instrument Panel Wire (Upper the Glove Box)

: Ground Points

Code	See Page	Ground Points Location
B3	50	Rear Side of Left Bank Cylinder Block
B4		

Charging

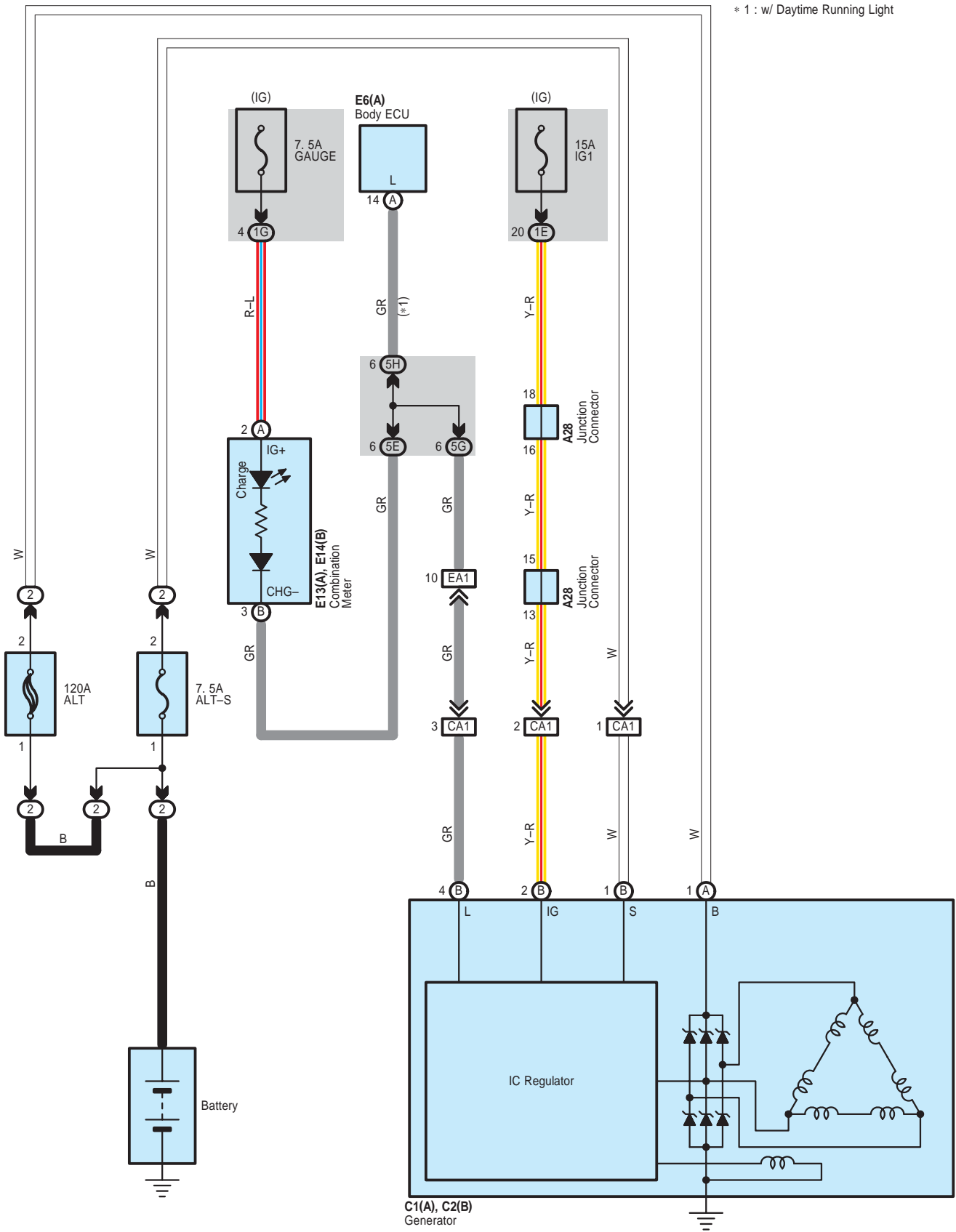

: Parts Location

Code		See Page	Code		See Page	Code		See Page
A28		38	C2	B	41	E13	A	42
C1	A	41	E6	A	42	E14	B	42

: Relay Blocks

Code	See Page	Relay Blocks (Relay Block Location)
2	22	Engine Room R/B No.2 (Engine Compartment Left)

: Junction Block and Wire Harness Connector

Code	See Page	Junction Block and Wire Harness (Connector Location)
1E	24	Engine Room Main Wire and Driver Side J/B (Lower Finish Panel)
1G	25	Instrument Panel Wire and Driver Side J/B (Lower Finish Panel)
5E	28	Instrument Panel Wire and Center J/B LH (Instrument Panel LH)
5G		
5H		

: Connector Joining Wire Harness and Wire Harness

Code	See Page	Joining Wire Harness and Wire Harness (Connector Location)
CA1	50	Engine No.2 Wire and Engine Room Main Wire (Near the Engine Room R/B No.2)
EA1	51	Instrument Panel Wire and Engine Room Main Wire (Left Kick Panel)

Engine Control

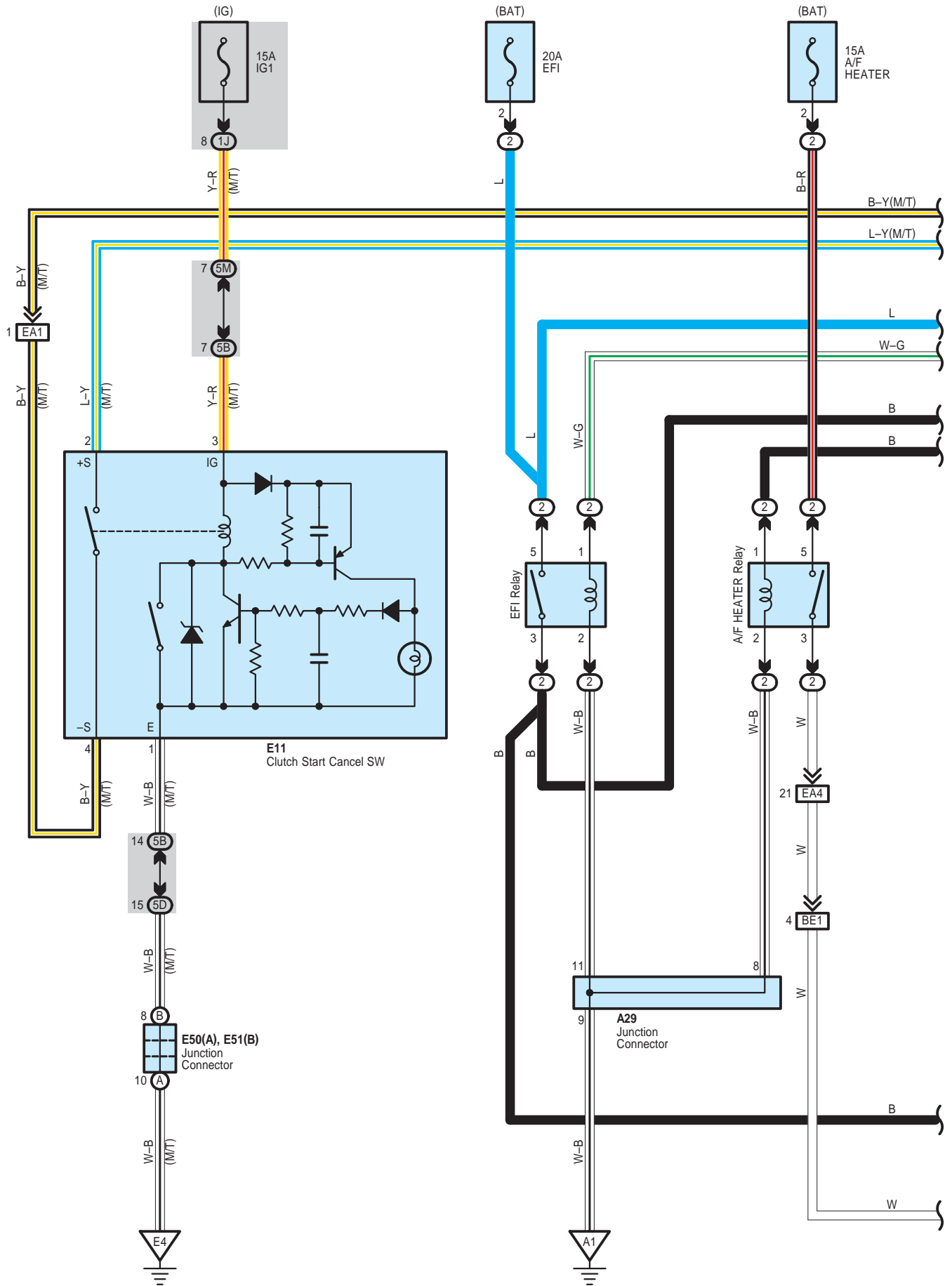

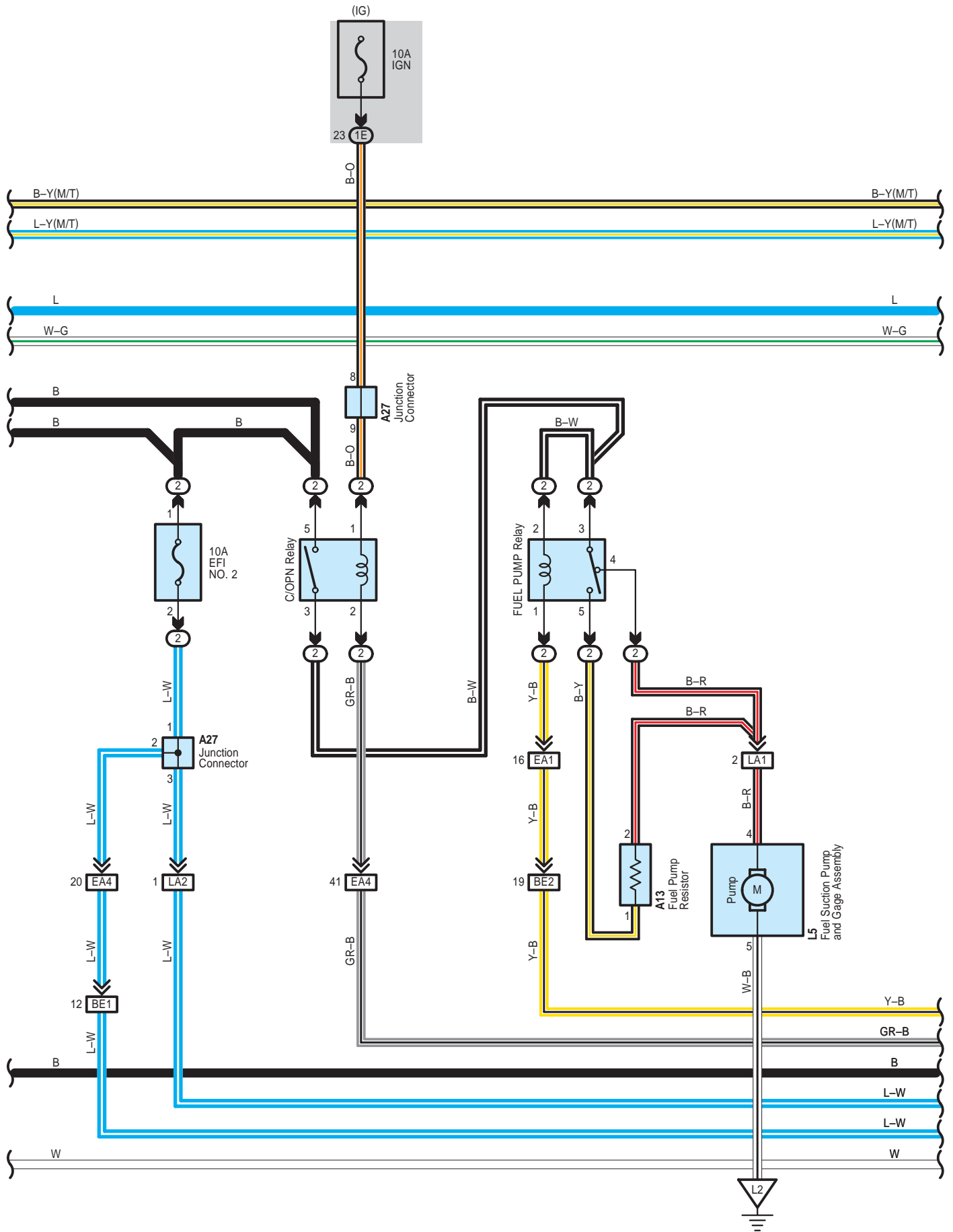

Engine Control

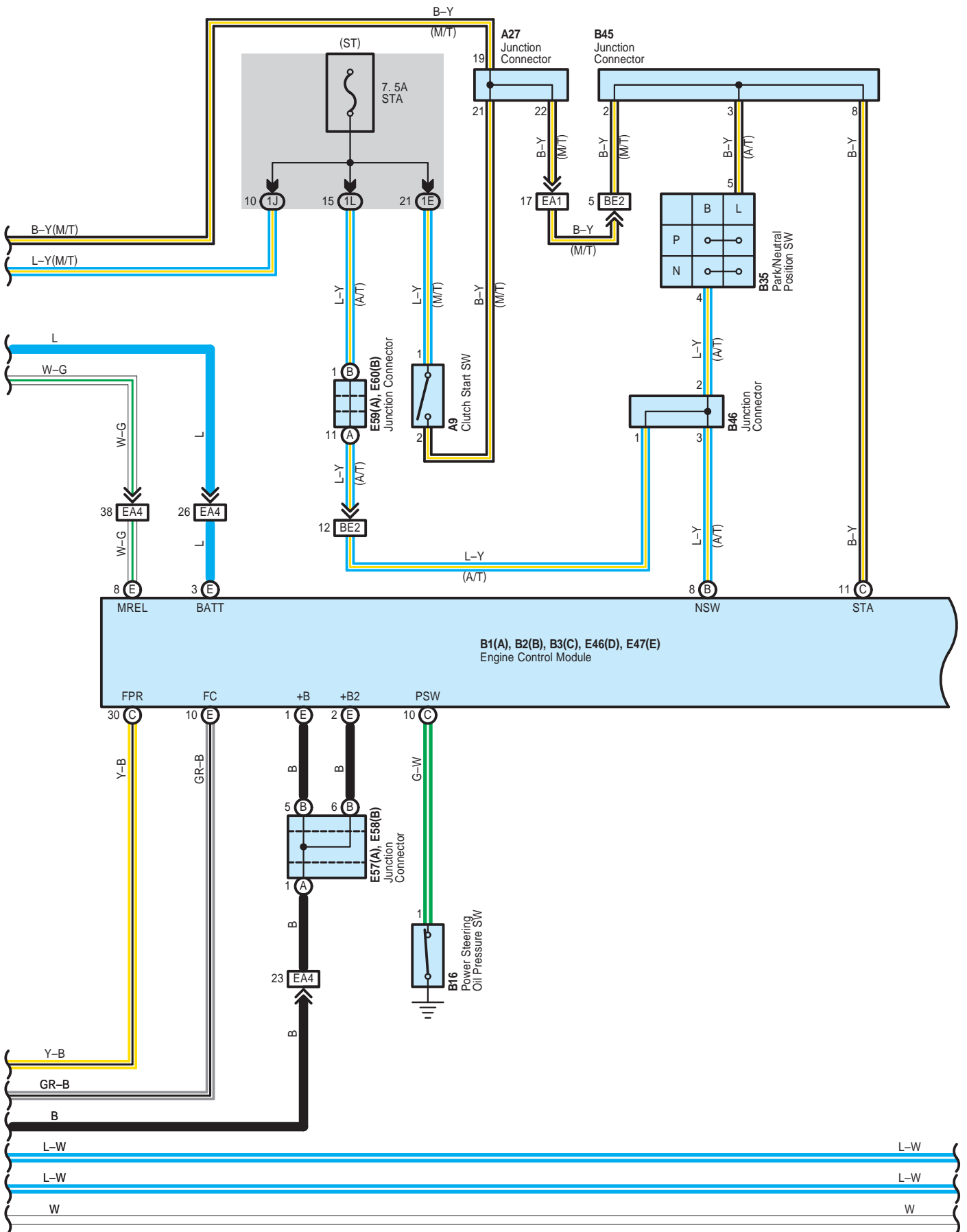

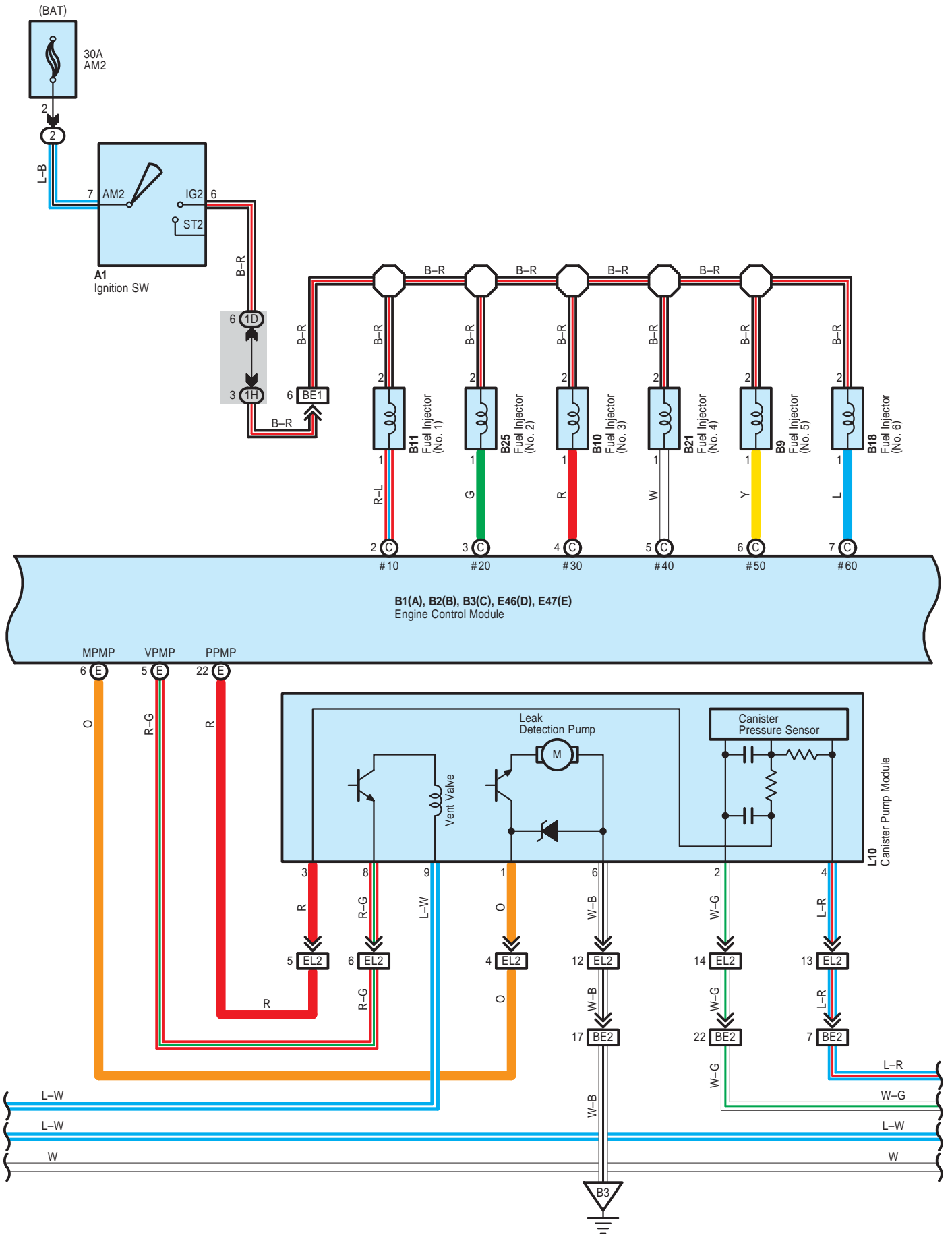

Engine Control

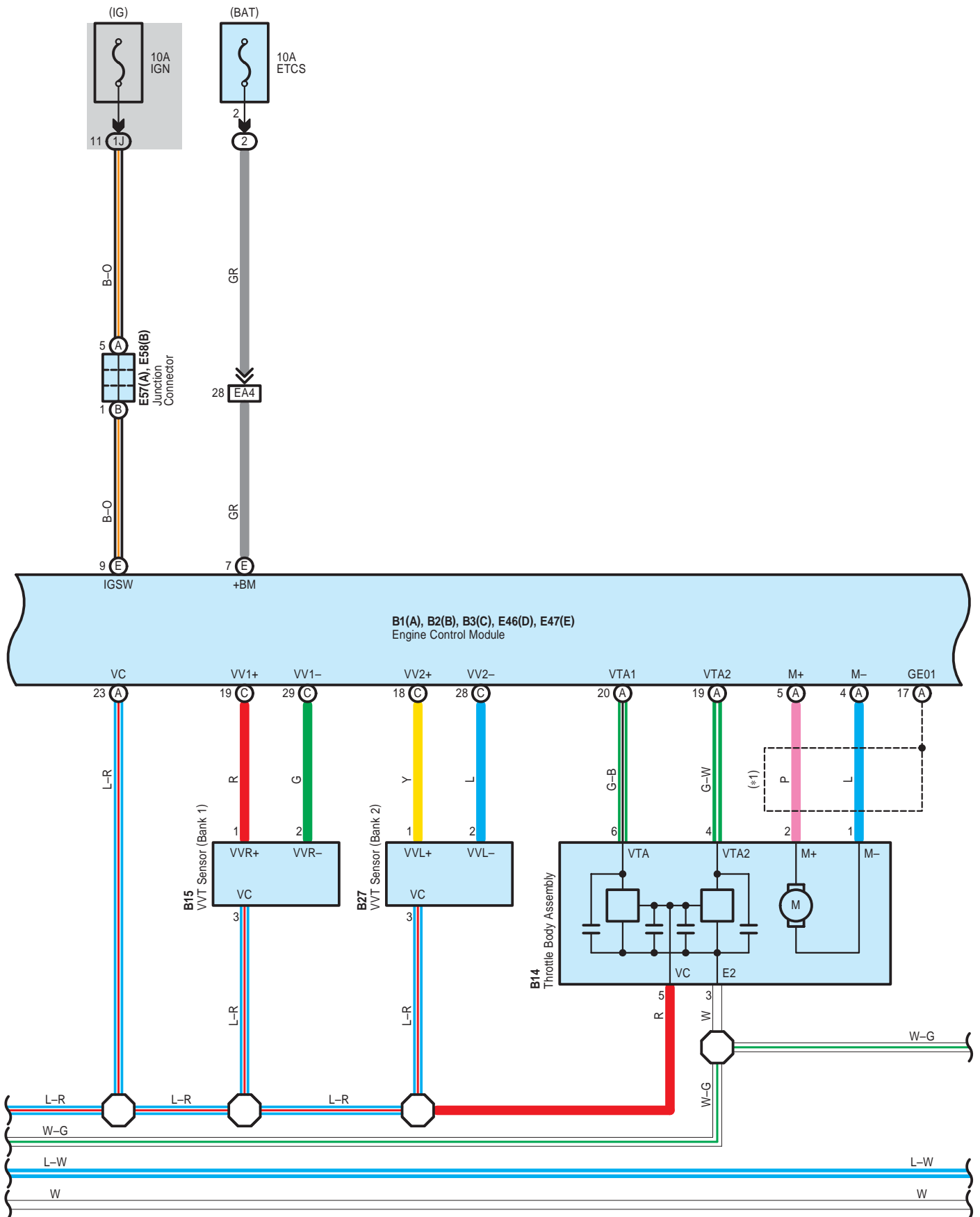

* 1 : Shielded

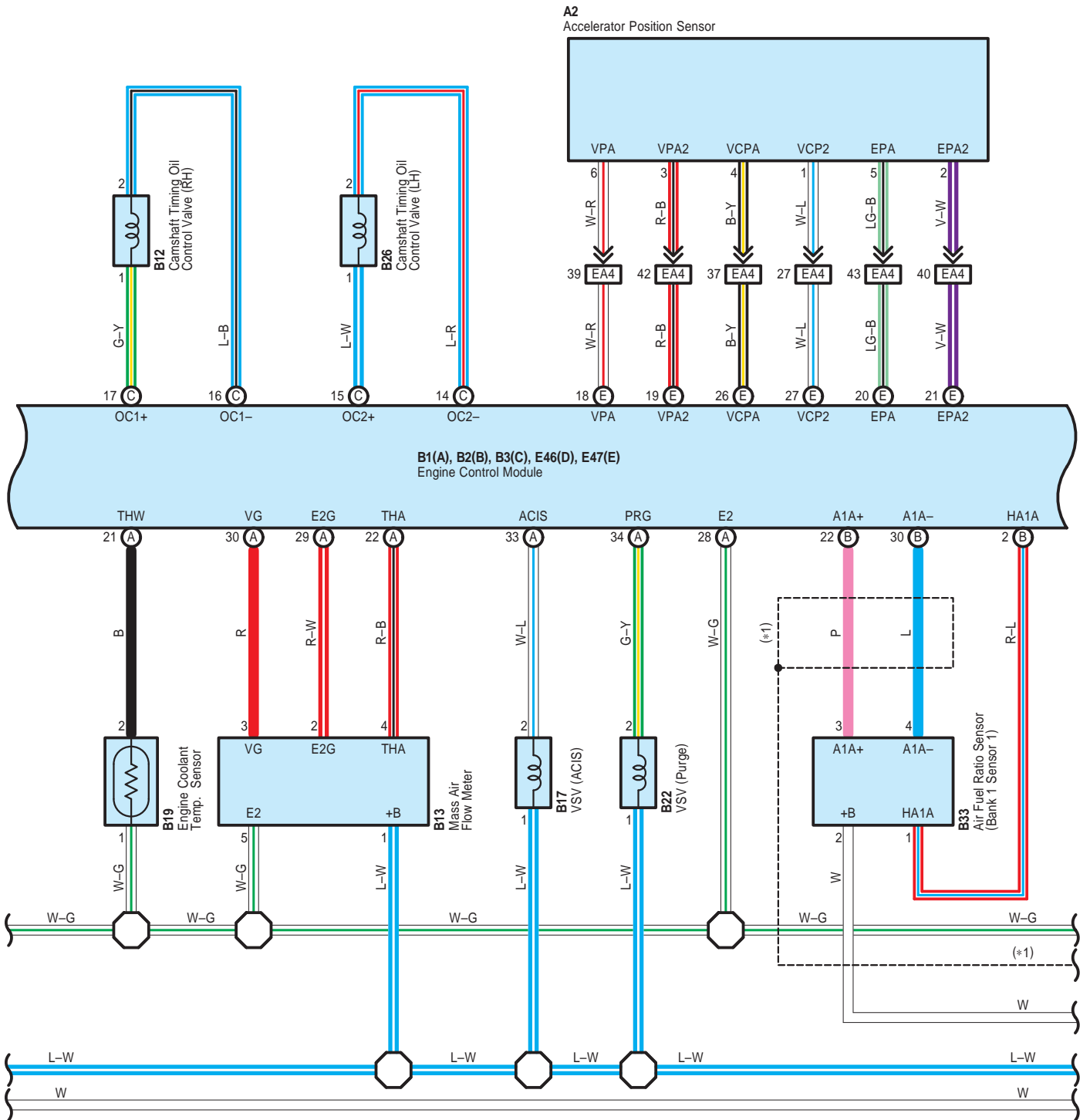

Engine Control

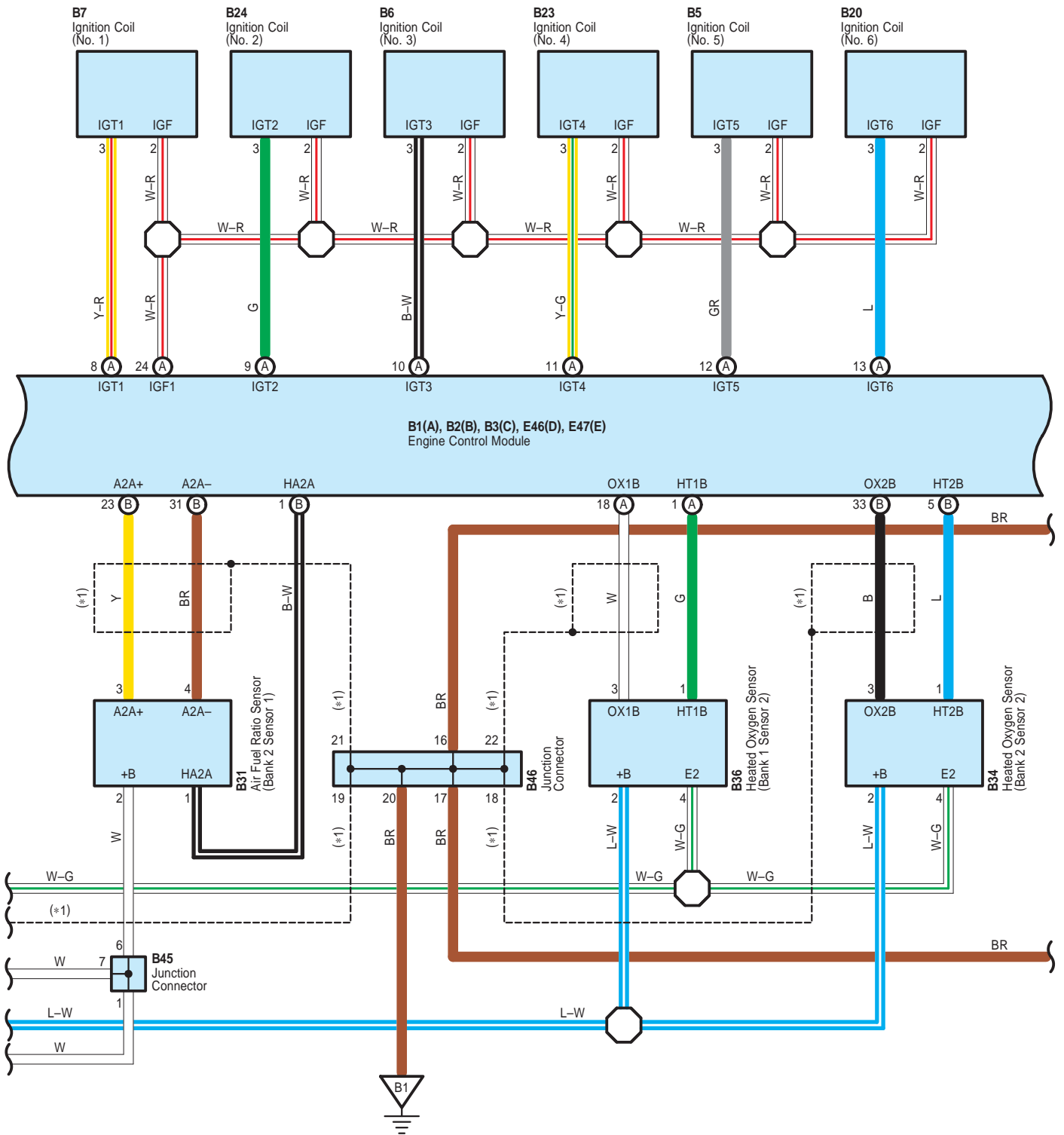

* 1 : Shielded

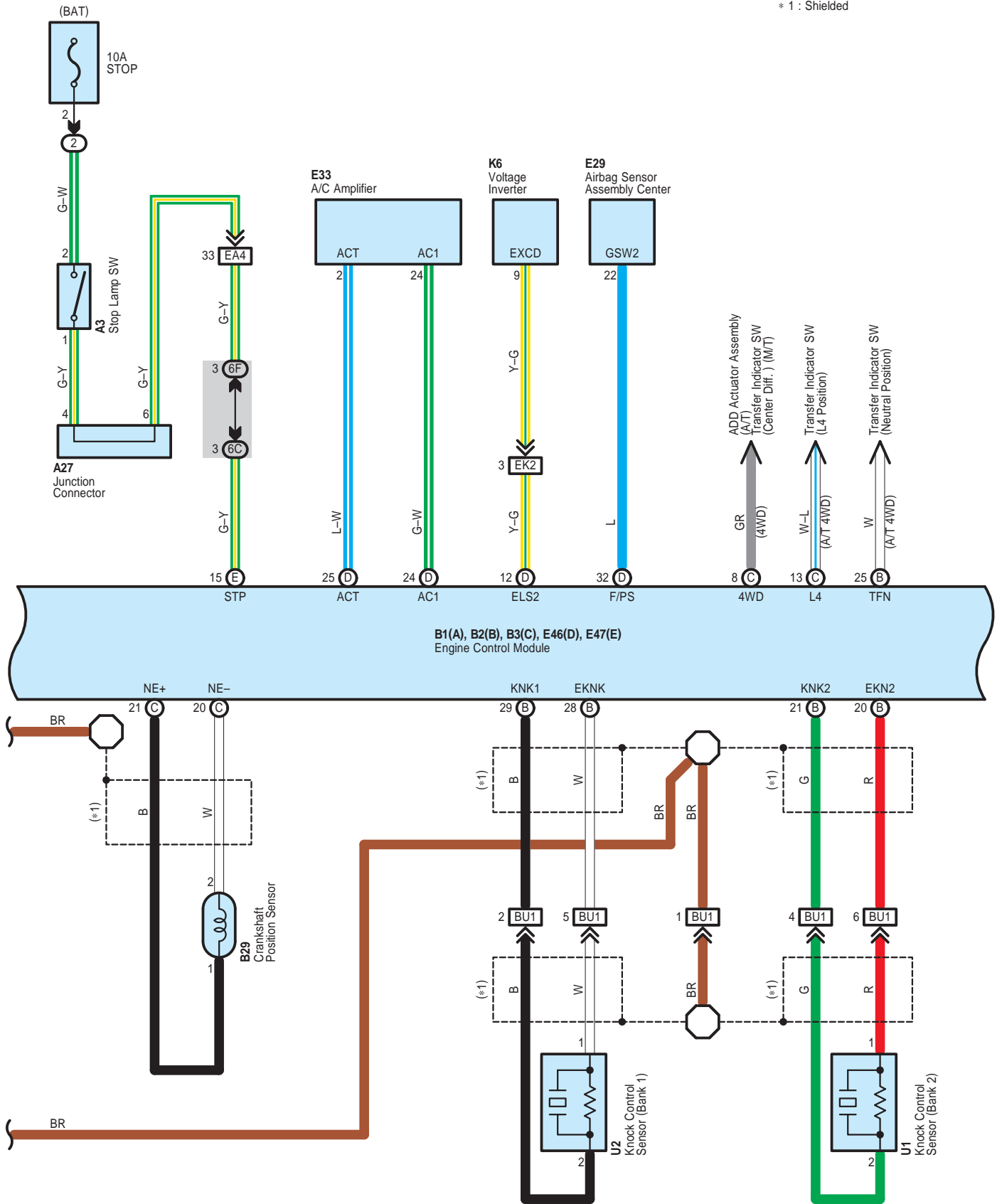

Engine Control

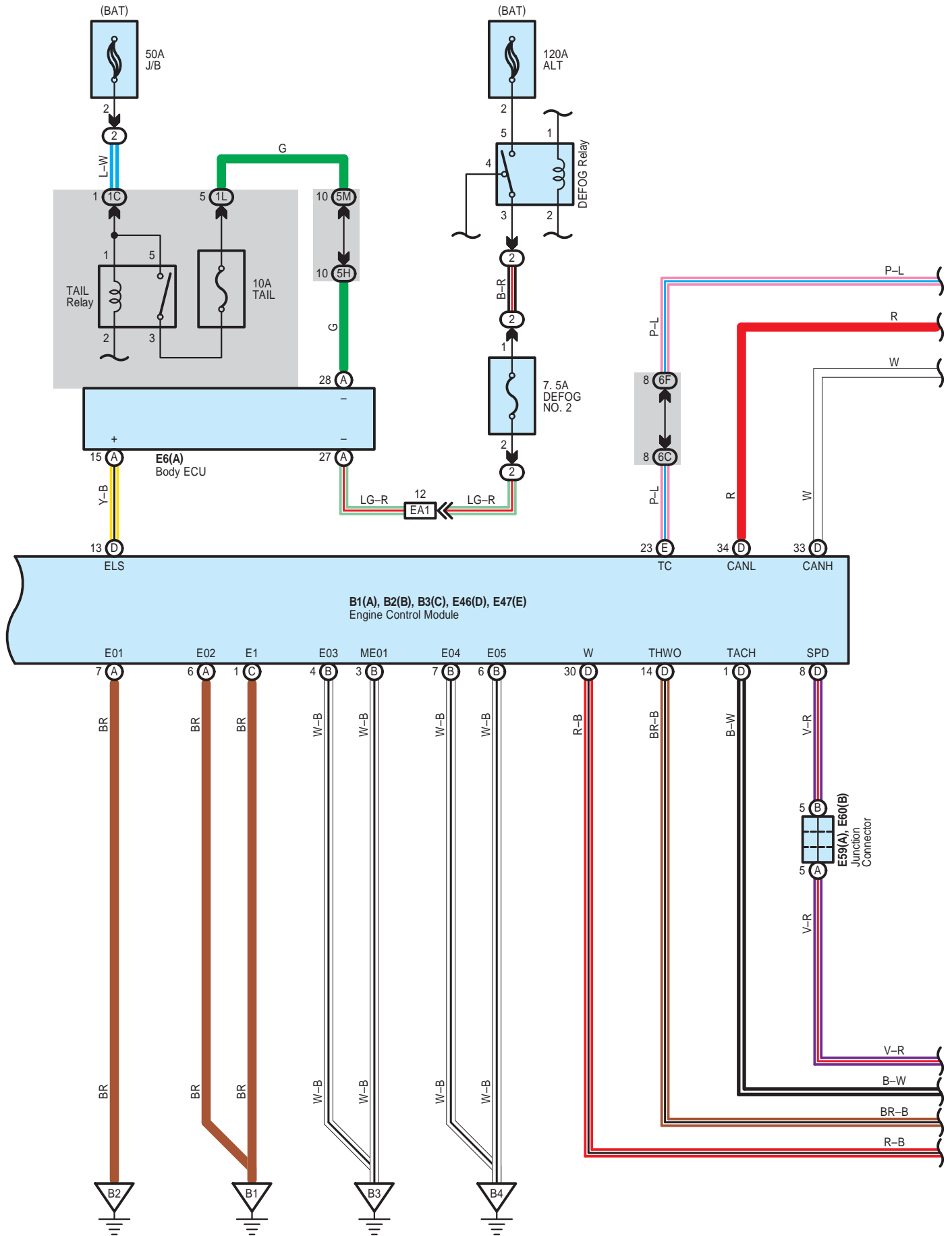

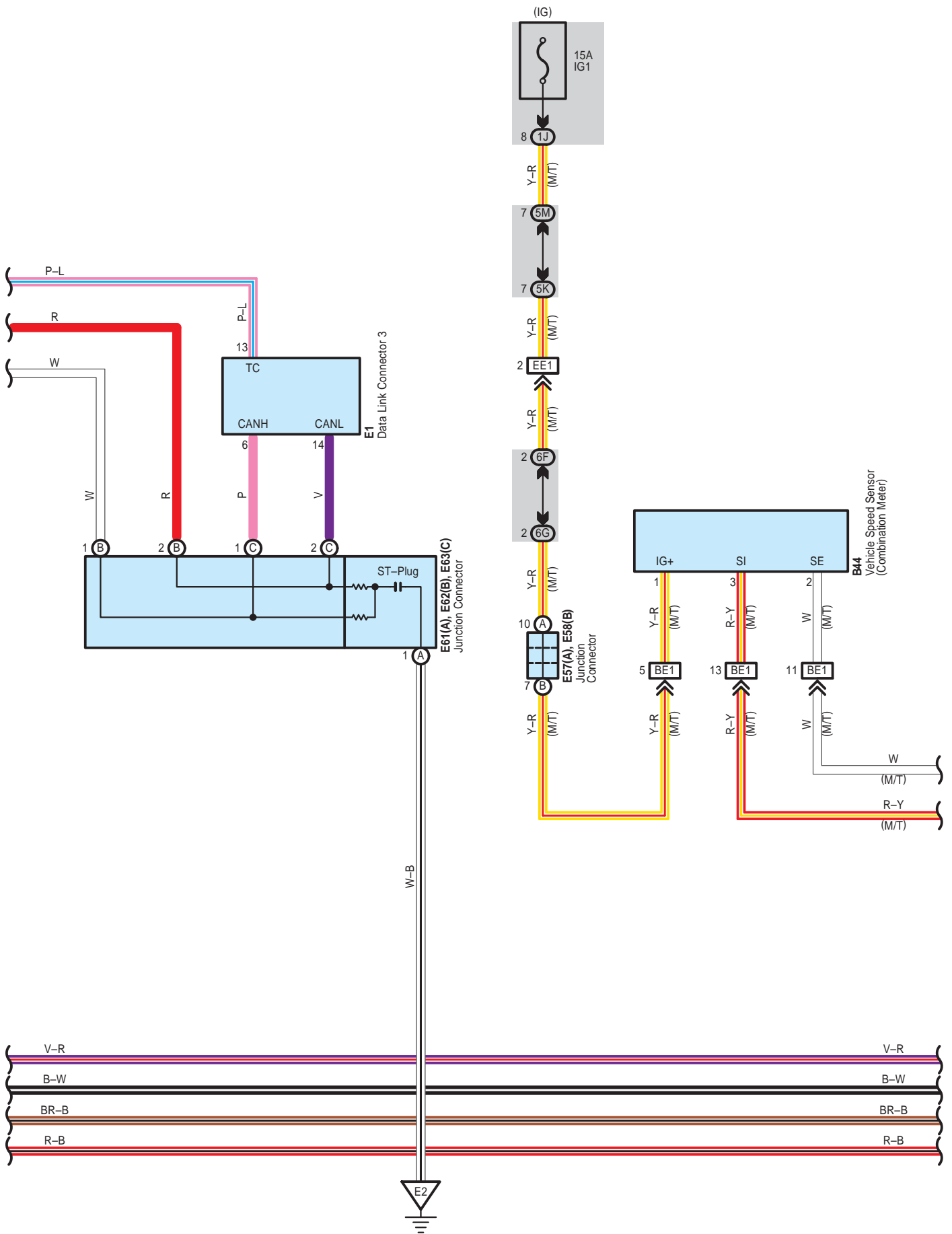

Engine Control

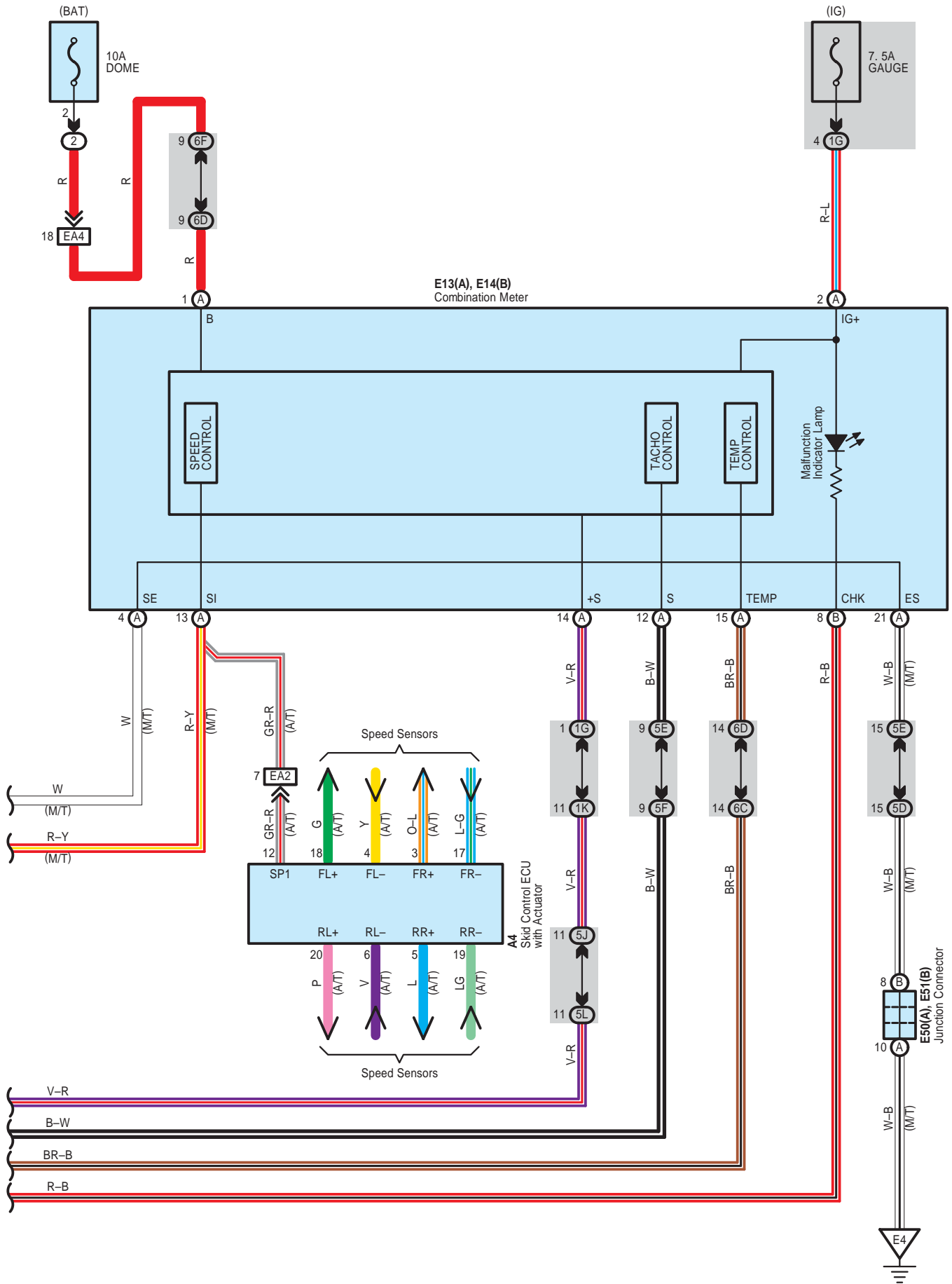

System Outline

The engine control system utilizes a microcomputer and maintains overall control of the engine, transmission etc. An outline of the engine control is given here.

1. Input Signals

- (1) Engine coolant temp. signal circuit
The engine coolant temp. sensor detects the engine coolant temp. and has a built-in thermistor with a resistance which varies according to the engine coolant temp. The engine coolant temp. is input into TERMINAL THW of the engine control module as a control signal.
- (2) Intake air temp. signal circuit
The intake air temp. sensor is installed in the mass air flow meter and detects the intake air temp., which is input as a control signal to TERMINAL THA of the engine control module.
- (3) Oxygen sensor signal circuit
The oxygen density in the exhaust emission is detected and is input as a control signal from the heated oxygen sensors to TERMINALS OX1B and OX2B of the engine control module.
- (4) RPM signal circuit
The camshaft position is detected by the VVT sensor bank 1 and bank 2, and is input into TERMINALS VV1+ and VV2+ of the engine control module as a control signal. Also, the engine RPM is detected by the crankshaft position sensor and the signal is input into TERMINAL NE+ of the engine control module.
- (5) Throttle position sensor signal circuit
The throttle position sensor detects the throttle valve opening angle as a control signal, which is input into TERMINALS VTA1 and VTA2 of the engine control module.
- (6) Vehicle speed circuit
The vehicle speed sensor detects the vehicle speed, and the signal is input into TERMINAL SPD of the engine control module via the combination meter, from TERMINAL SP1 of the skid control ECU with actuator. (A/T)
The vehicle speed sensor (Combination meter) detects the vehicle speed, and the signal is input into TERMINAL SPD of the engine control module via the combination meter. (M/T)
- (7) Battery signal circuit
Voltage is constantly applied to TERMINAL BATT of the engine control module. When the ignition SW is turned on, the voltage for engine control module start up power supply is applied through the EFI relay, to TERMINALS +B and +B2 of the engine control module. The current from the IGN fuse flows to TERMINAL IGSW of the engine control module, and voltage is constantly applied to TERMINAL +BM.
- (8) Intake air volume signal circuit
The intake air volume is detected by the mass air flow meter, and is input as a control signal to TERMINAL VG of the engine control module.
- (9) Stop lamp SW signal circuit
The stop lamp SW is used to detect whether the vehicle is braking or not, and the signal is input into TERMINAL STP of the engine control module as a control signal.
- (10) Starter signal circuit
To confirm whether the engine is cranking, the voltage applied to the starter motor when the engine is cranking is detected, and is input into TERMINAL STA of the engine control module as a control signal.
- (11) Engine knock signal circuit
Engine knocking is detected by the knock sensors, and is input into TERMINALS KNK1 and KNK2 of the engine control module as a control signal.
- (12) A/C SW signal system
The operating voltage of the A/C magnetic clutch is detected and input in the form of a control signal to TERMINAL AC1 of the engine control module.
- (13) Air fuel ratio signal circuit
The air fuel ratio is detected and input as a control signal into TERMINALS A1A+ and A2A+ of the engine control module.

2. Control System

* SFI system

The SFI system monitors the engine condition through the signals input from each sensors to the engine control module. The control signal is sent to the engine control module TERMINALS #10, #20, #30, #40, #50 and #60 to operate the injector (Fuel injection). The SFI system controls the fuel injection by the engine control module in response to the driving conditions.

* ESA system

The ESA system monitors the engine condition through the signals input from each sensors to the engine control module. The best ignition timing is decided according to this data and the data memorized in the engine control module. The control signal is output to TERMINALS IGT1, IGT2, IGT3, IGT4, IGT5 and IGT6, and these signals control the igniter to provide the best ignition timing.

* Heated oxygen sensor heater control system

The heated oxygen sensor heater control system turns the heater on when the intake air volume is low (Temp. of exhaust emission is low), and warms up the heated oxygen sensors to improve their detection performance. The engine control module evaluates the signals from each sensors, and outputs current to TERMINAL HT1B or HT2B to control the heater.

* Air fuel ratio sensor heater control system

The air fuel ratio sensor heater control system turns the heater on when the intake air volume is low (Temp. of exhaust emission is low), and warms up the air fuel ratio sensor to improve detection performance of the sensor.

The engine control module evaluates the signals from each sensor, current is output to TERMINALS HA1A and HA2A, controlling the heater.

* Fuel pump control system

The engine control module supplies current to TERMINAL FPR, and controls the operation speed of the fuel pump with the FUEL PUMP relay.

* ACIS

The ACIS includes a valve in the bulkhead separating the surge tank into two parts. This valve is opened and closed in accordance with the driving conditions to control the intake manifold length in two stages, for increased engine output in all ranges from low to high speeds.

* ETCS-i

The ETCS-i controls the engine output at its optimal level in accordance with the opening of the accelerator pedal, under all driving conditions.

* VVT-i

Controls the intake camshaft to an optimal valve timing in accordance with the engine condition.

3. Diagnosis System

When there is a malfunction in the engine control module signal system, the malfunctioning system is recorded in the memory. The malfunctioning system can be found by reading the code displayed on the malfunction indicator lamp.

4. Fail-Safe System

When a malfunction has occurred in any system, there is a possibility of causing engine trouble due to continued control based on that system. In that case, the fail-safe system either controls the system using the data (Standard values) recorded in the engine control module memory, or else stops the engine.

○ : Parts Location

Code	See Page	Code	See Page	Code	See Page
A1	45	B17	39	E11	42
A2	45	B18	39	E13	A 42
A3	45	B19	39	E14	B 42
A4	38	B20	39	E29	43
A9	45	B21	39	E33	43
A13	38	B22	39	E46	D 43
A27	45	B23	39	E47	E 43
A29	38	B24	39	E50	A 44
B1	A 45	B25	39	E51	B 44
B2	B 45	B26	40	E57	A 44
B3	C 45	B27	40	E58	B 44
B5	39	B29	40	E59	A 44
B6	39	B31	40	E60	B 44
B7	39	B33	40	E61	A 36, 44
B9	39	B34	40	E62	B 36, 44
B10	39	B35	40	E63	C 36, 44
B11	39	B36	40	K6	46
B12	39	B44	40	L5	46
B13	39	B45	45	L10	46
B14	39	B46	45	U1	41
B15	39	E1	42	U2	41
B16	39	E6	A 42		

○ : Relay Blocks

Code	See Page	Relay Blocks (Relay Block Location)
2	22	Engine Room R/B No.2 (Engine Compartment Left)

○ : Junction Block and Wire Harness Connector

Code	See Page	Junction Block and Wire Harness (Connector Location)
1C	24	Engine Room Main Wire and Driver Side J/B (Lower Finish Panel)
1D		
1E		
1G	25	Instrument Panel Wire and Driver Side J/B (Lower Finish Panel)
1H		
1J		
1K		
1L		
5B	28	Instrument Panel Wire and Center J/B LH (Instrument Panel LH)
5D		
5E		
5F		
5H		
5J		
5K		
5L		
5M		
6C	32	Instrument Panel Wire and Center J/B RH (Instrument Panel RH)
6D		
6F		
6G		

Engine Control

 : Connector Joining Wire Harness and Wire Harness

Code	See Page	Joining Wire Harness and Wire Harness (Connector Location)
BE1	51	Engine Wire and Instrument Panel Wire (Upper the Glove Box)
BE2		
BU1	50	Engine Wire and Sensor Wire (Rear Side of Right Bank Cylinder Block)
EA1	51	Instrument Panel Wire and Engine Room Main Wire (Left Kick Panel)
EA2		
EA4		
EE1	51	Instrument Panel Wire and Instrument Panel Wire (Instrument Panel RH)
EK2	51	Instrument Panel Wire and Floor Wire (Right Kick Panel)
EL2	51	Instrument Panel Wire and Floor No.2 Wire (Left Kick Panel)
LA1	51	Floor No.2 Wire and Engine Room Main Wire (Left Kick Panel)
LA2		

 : Ground Points

Code	See Page	Ground Points Location
A1	50	Left Fender Apron
B1	50	Rear Side of Right Bank Cylinder Block
B2		
B3	50	Rear Side of Left Bank Cylinder Block
B4		
E2	51	Instrument Panel Brace LH
E4	51	Left Kick Panel
L2	52	Left Quarter Panel

Data Link Connector 3

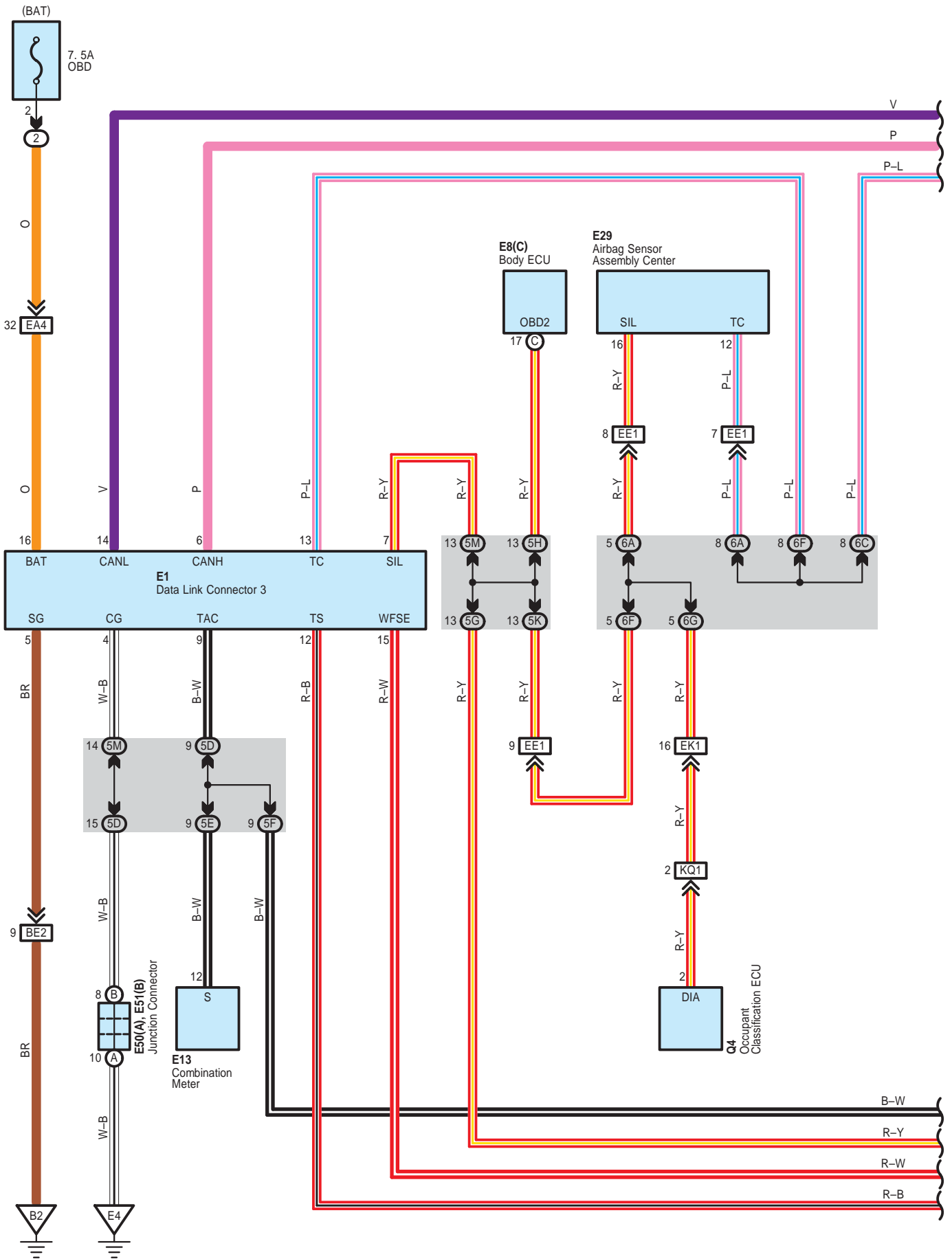

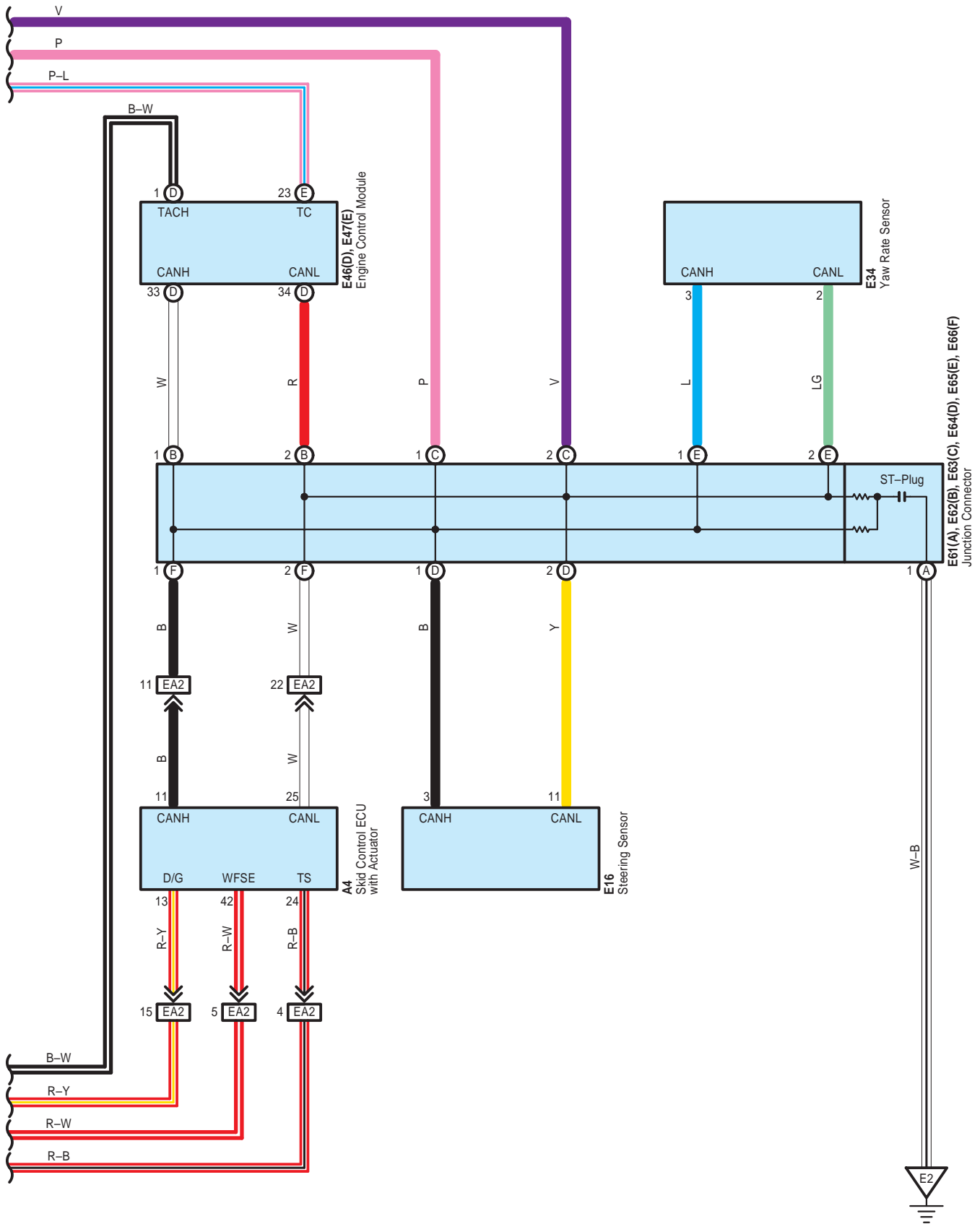

Data Link Connector 3

: Parts Location

Code	See Page	Code	See Page	Code	See Page
A4	38	E34	43	E62	B 36, 44
E1	42	E46	D 43	E63	C 36, 44
E8	C 42	E47	E 43	E64	D 36, 44
E13	42	E50	A 44	E65	E 36, 44
E16	42	E51	B 44	E66	F 36, 44
E29	43	E61	A 36, 44	Q4	48

: Relay Blocks

Code	See Page	Relay Blocks (Relay Block Location)
2	22	Engine Room R/B No.2 (Engine Compartment Left)

: Junction Block and Wire Harness Connector

Code	See Page	Junction Block and Wire Harness (Connector Location)
5D	28	Instrument Panel Wire and Center J/B LH (Instrument Panel LH)
5E		
5F		
5G		
5H		
5K		
5M	32	Instrument Panel Wire and Center J/B RH (Instrument Panel RH)
6A		
6C		
6F		
6G		

: Connector Joining Wire Harness and Wire Harness

Code	See Page	Joining Wire Harness and Wire Harness (Connector Location)
BE2	51	Engine Wire and Instrument Panel Wire (Upper the Glove Box)
EA2	51	Instrument Panel Wire and Engine Room Main Wire (Left Kick Panel)
EA4		
EE1	51	Instrument Panel Wire and Instrument Panel Wire (Instrument Panel RH)
EK1	51	Instrument Panel Wire and Floor Wire (Right Kick Panel)
KQ1	53	Floor Wire and Seat No.1 Wire (Under the Front Seat RH)

: Ground Points

Code	See Page	Ground Points Location
B2	50	Rear Side of Right Bank Cylinder Block
E2	51	Instrument Panel Brace LH
E4	51	Left Kick Panel

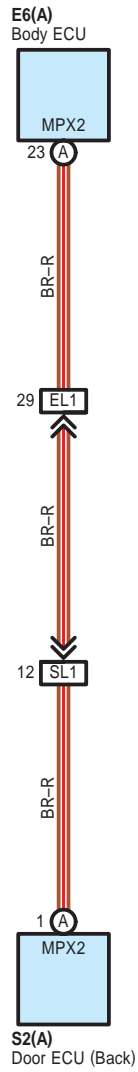

○ : Parts Location

Code		See Page	Code		See Page	Code		See Page
E6	A	42	S2	A	47			

□ : Connector Joining Wire Harness and Wire Harness

Code	See Page	Joining Wire Harness and Wire Harness (Connector Location)
EL1	51	Instrument Panel Wire and Floor No.2 Wire (Left Kick Panel)
SL1	52	Back Door No.1 Wire and Floor No.2 Wire (Left Quarter Panel)

Multiplex Communication System – CAN

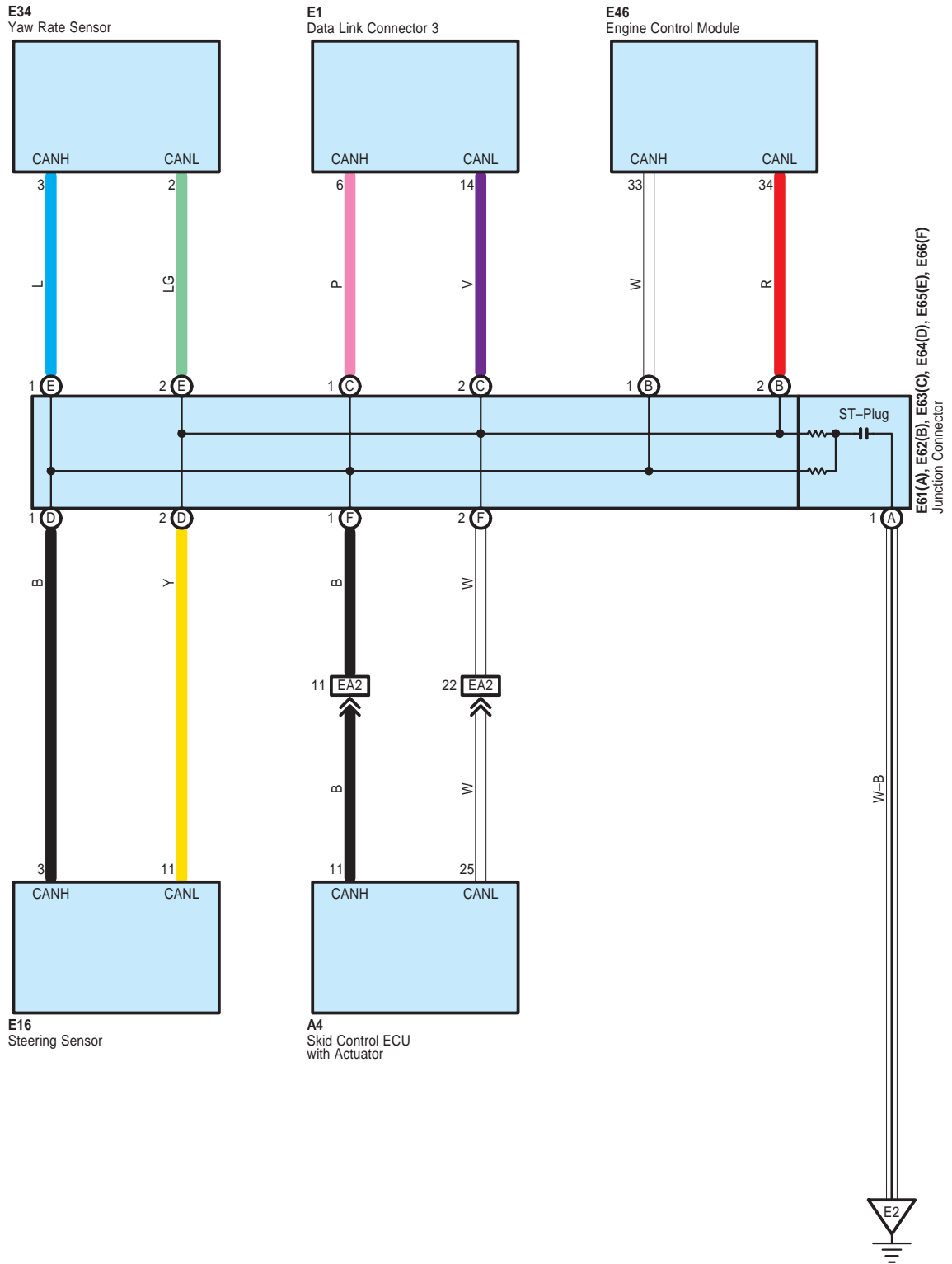

System Outline

CAN has two lines as a pair which make communication with operating voltage. CAN has excellent data speed and error detecting capacity. It consists of vehicle control systems such as engine control module, data link connector 3, skid control ECU with actuator, steering sensor and yaw rate sensor.

○ : Parts Location

Code	See Page	Code	See Page	Code	See Page
A4	38	E46	43	E64	D 36, 44
E1	42	E61	A 36, 44	E65	E 36, 44
E16	42	E62	B 36, 44	E66	F 36, 44
E34	43	E63	C 36, 44		

□ : Connector Joining Wire Harness and Wire Harness

Code	See Page	Joining Wire Harness and Wire Harness (Connector Location)
EA2	51	Instrument Panel Wire and Engine Room Main Wire (Left Kick Panel)

▽ : Ground Points

Code	See Page	Ground Points Location
E2	51	Instrument Panel Brace LH

Headlight

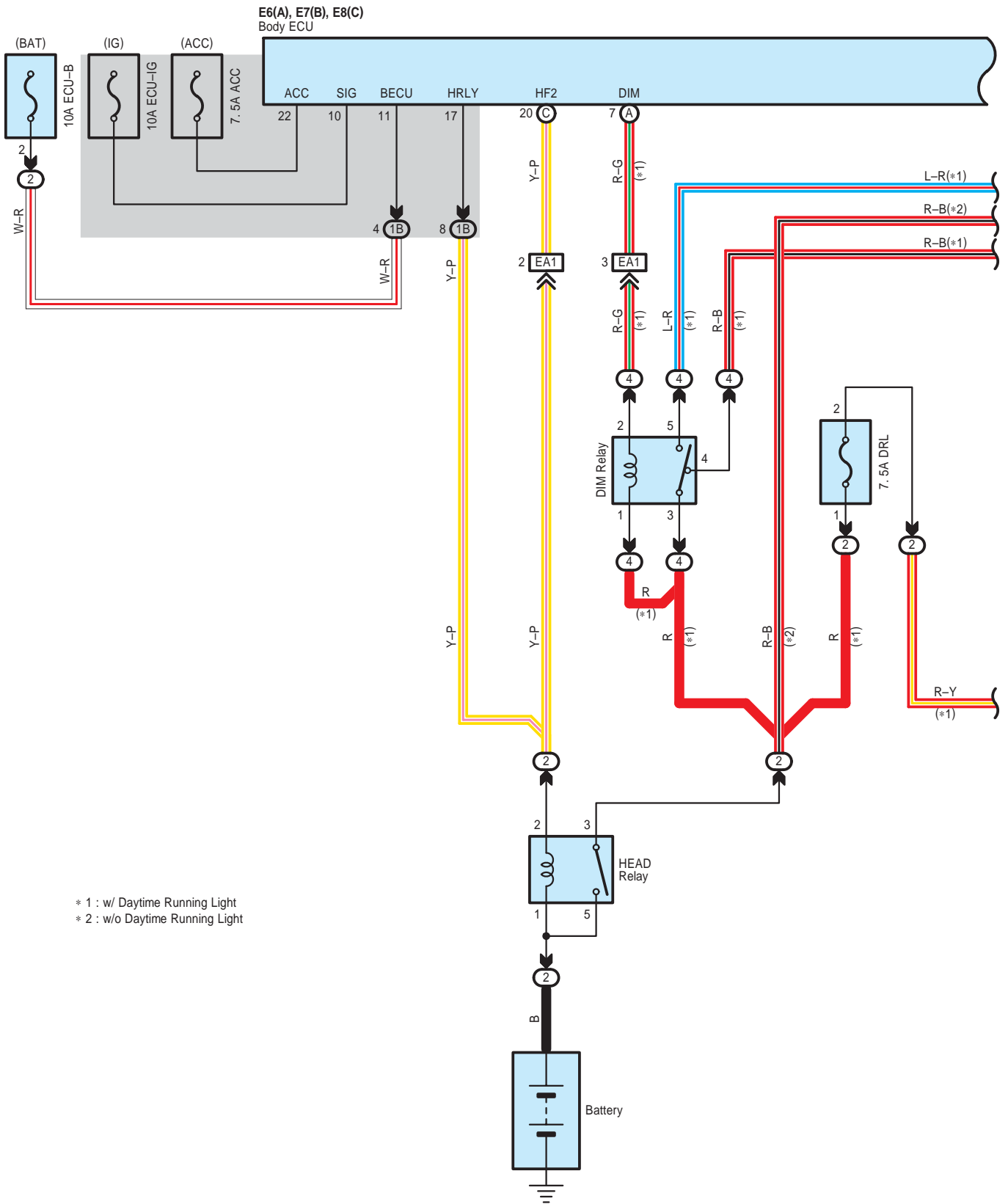

E6(A), E7(B), E8(C)
Body ECU

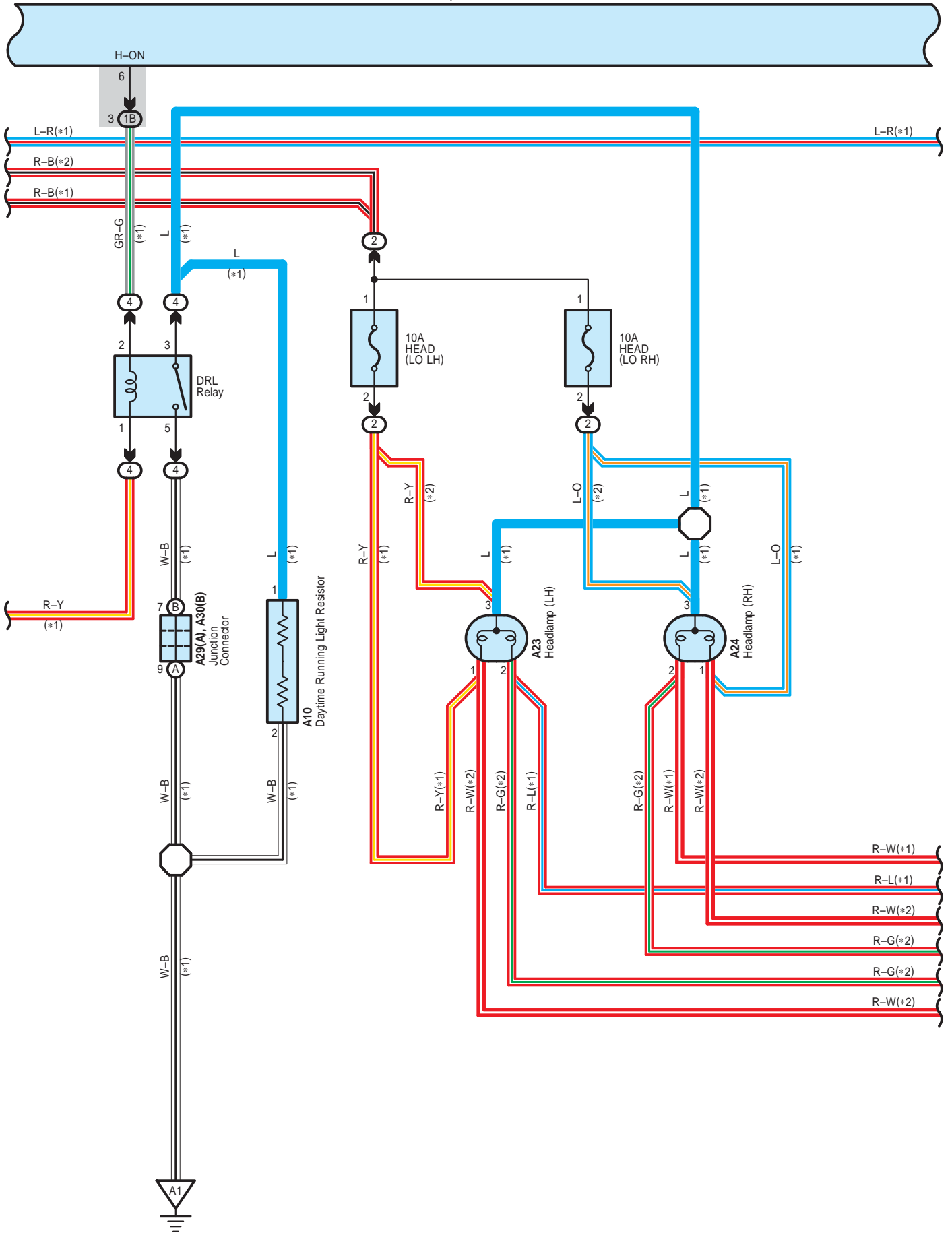

Headlight

E6(A), E7(B), E8(C)
Body ECU

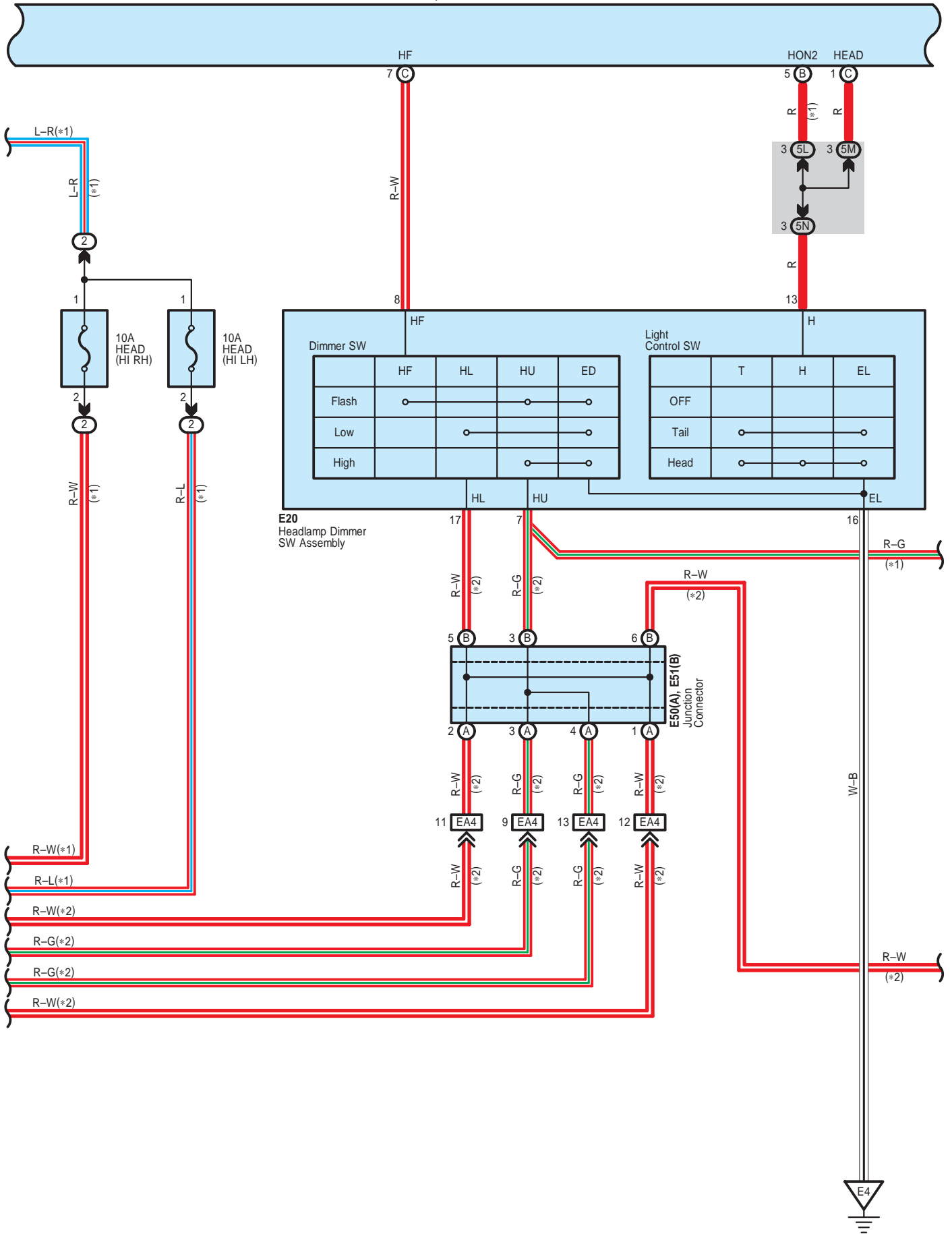

E6(A), E7(B), E8(C)
Body ECU

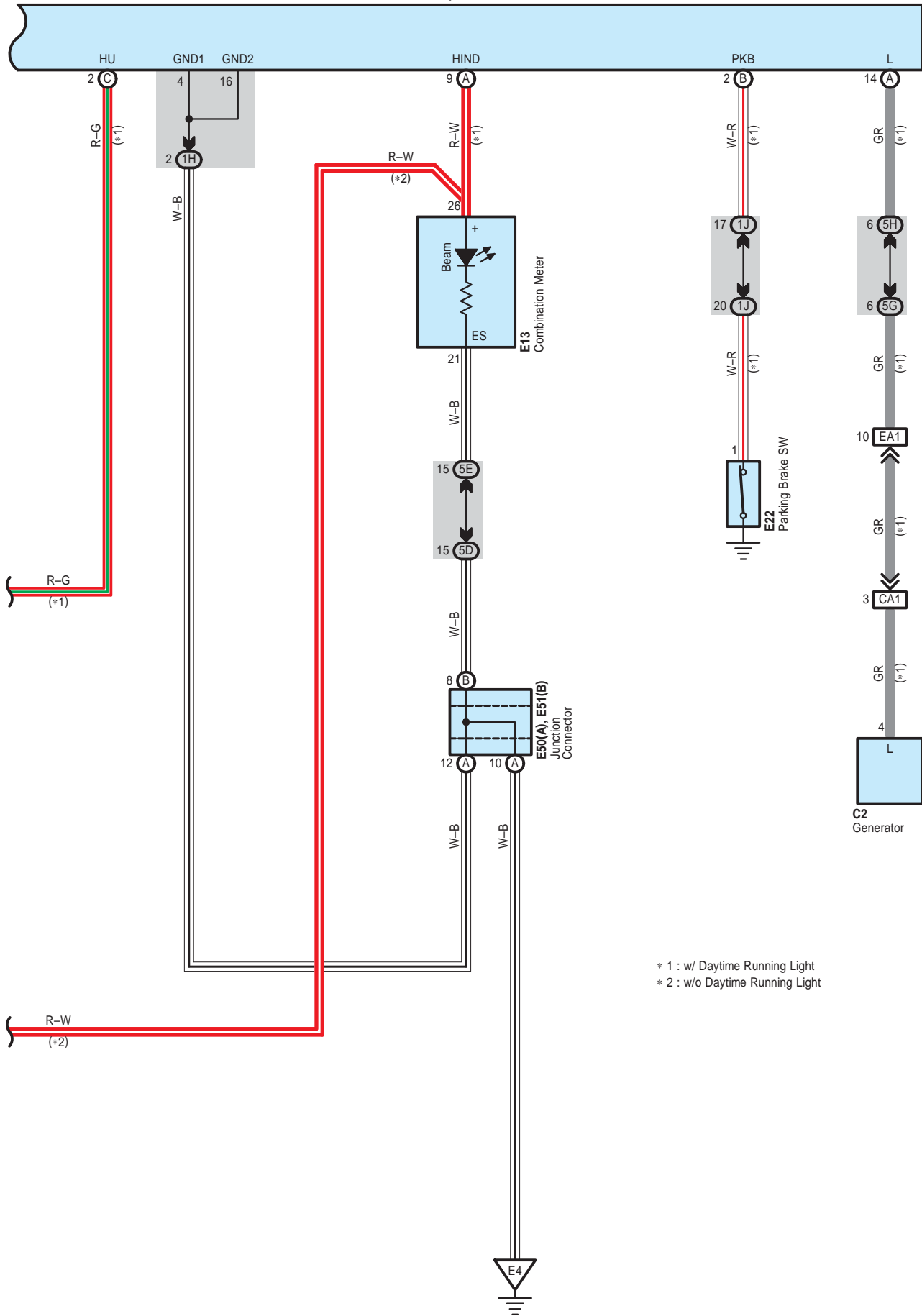

Headlight

System Outline

Daytime Running Light Operation

When the engine is started, a signal from the generator is input into TERMINAL (A) 14 of the body ECU. At this time, if the parking brake lever is pulled up (Parking brake SW ON), the body ECU is not activated, and the daytime running light system does not operate.

When the parking brake lever is released (Parking brake SW OFF), a signal is input into TERMINAL (B) 2 of the body ECU. This activates the body ECU and the headlight turns on.

○ : Parts Location

Code	See Page	Code	See Page	Code	See Page
A10	38	C2	41	E20	42
A23	38	E6	A 42	E22	42
A24	38	E7	B 42	E50	A 44
A29	A 38	E8	C 42	E51	B 44
A30	B 38	E13	42		

○ : Relay Blocks

Code	See Page	Relay Blocks (Relay Block Location)
2	22	Engine Room R/B No.2 (Engine Compartment Left)
4	23	Engine Room R/B No.4 (Engine Compartment Left)

○ : Junction Block and Wire Harness Connector

Code	See Page	Junction Block and Wire Harness (Connector Location)
1B	24	Engine Room Main Wire and Driver Side J/B (Lower Finish Panel)
1H	25	Instrument Panel Wire and Driver Side J/B (Lower Finish Panel)
1J		
5D	28	Instrument Panel Wire and Center J/B LH (Instrument Panel LH)
5E		
5G		
5H		
5L		
5M		
5N		

□ : Connector Joining Wire Harness and Wire Harness

Code	See Page	Joining Wire Harness and Wire Harness (Connector Location)
CA1	50	Engine No.2 Wire and Engine Room Main Wire (Near the Engine Room R/B No.2)
EA1	51	Instrument Panel Wire and Engine Room Main Wire (Left Kick Panel)
EA4		

▽ : Ground Points

Code	See Page	Ground Points Location
A1	50	Left Fender Apron
E4	51	Left Kick Panel

Light Auto Turn Off System

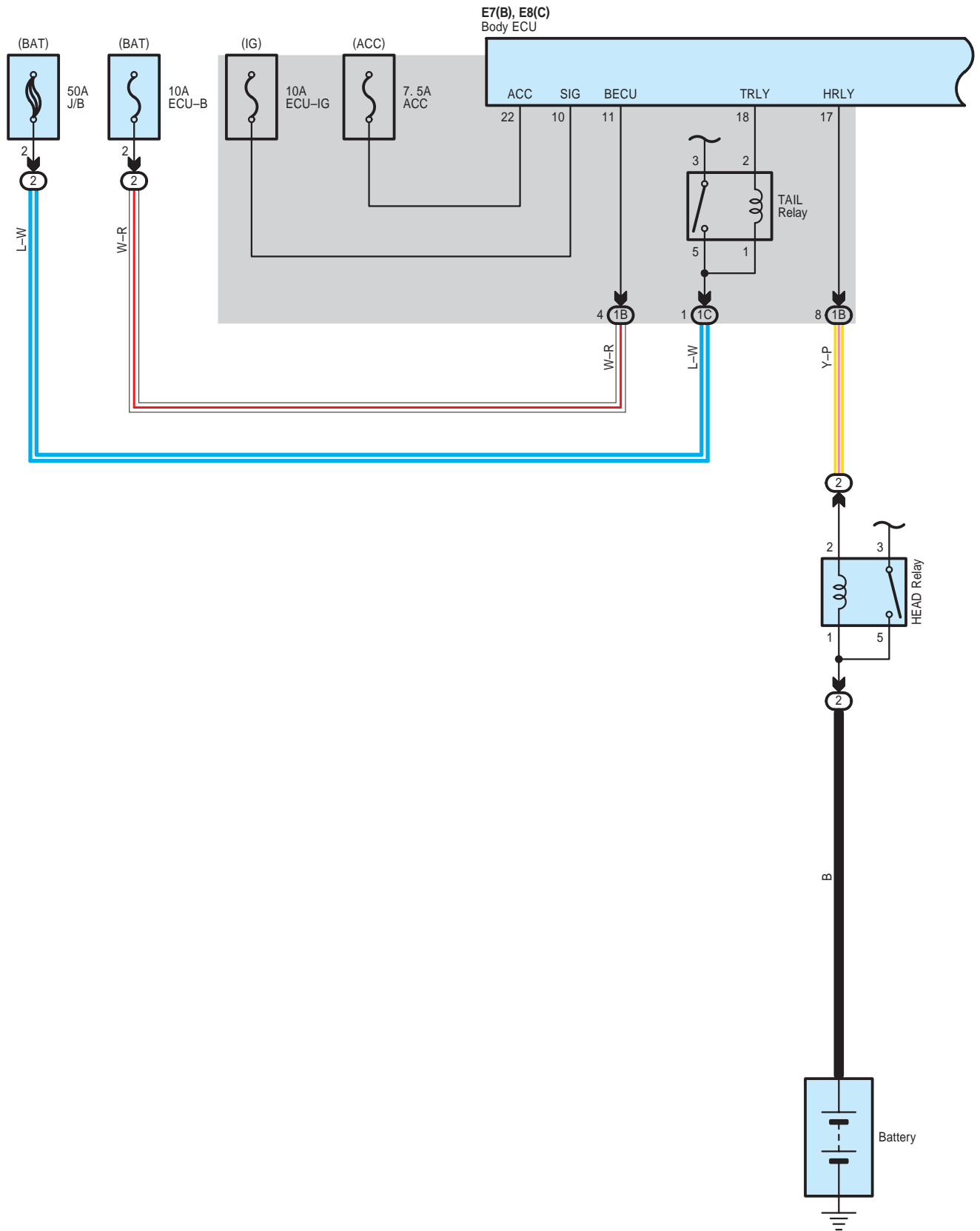

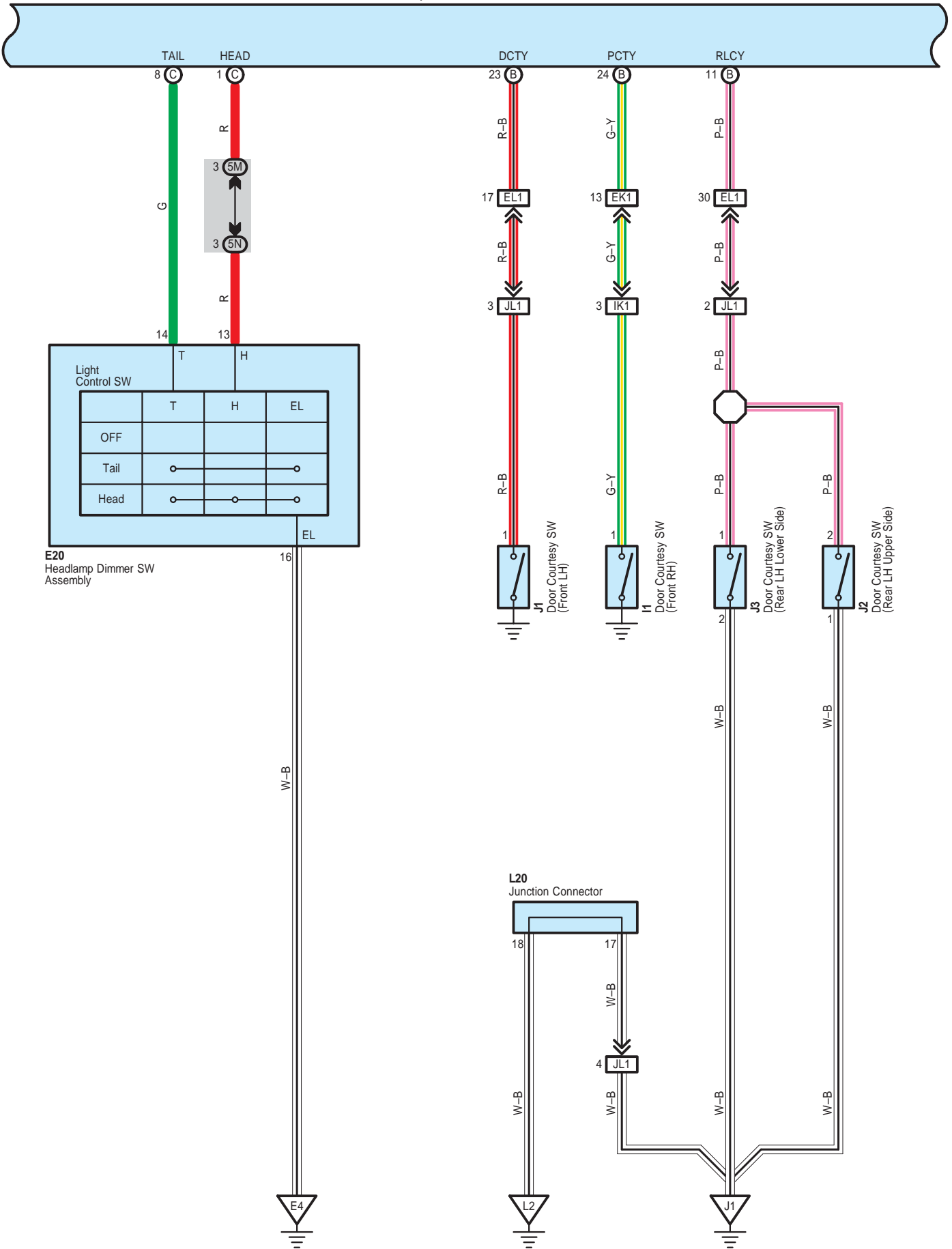

Light Auto Turn Off System

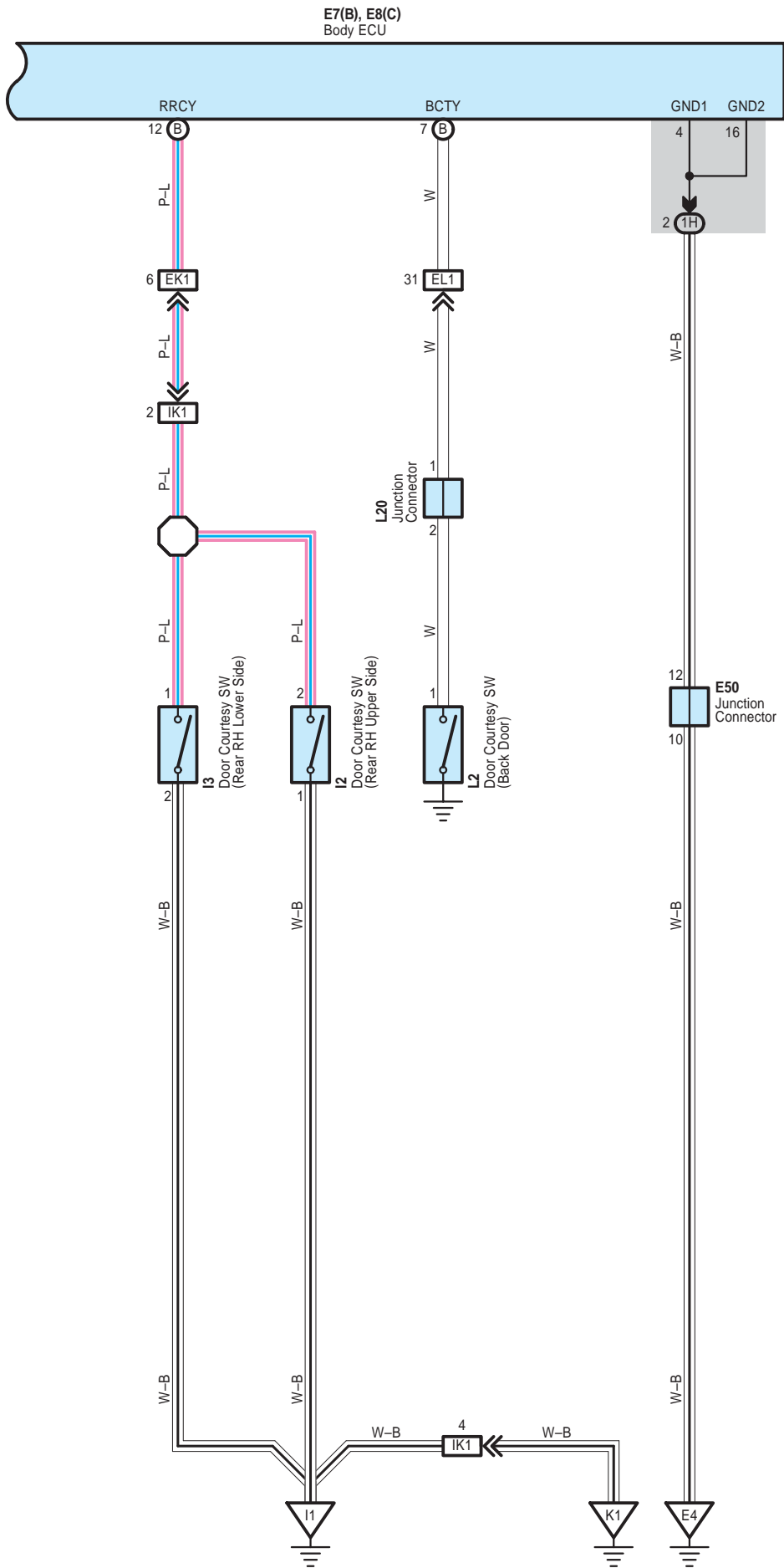

System Outline

If the ignition SW is turned OFF and driver's door is opened when the headlights and taillights are ON, the lights turn OFF automatically.

However, in models for North America, the lights remain illuminated for 30 seconds after the ignition SW is turned OFF and all the doors are closed.

○ : Parts Location

Code		See Page	Code	See Page	Code	See Page
E7	B	42	I1	47	J2	47
E8	C	42	I2	47	J3	47
E20		42	I3	47	L2	46
E50		44	J1	47	L20	46

○ : Relay Blocks

Code	See Page	Relay Blocks (Relay Block Location)
2	22	Engine Room R/B No.2 (Engine Compartment Left)

○ : Junction Block and Wire Harness Connector

Code	See Page	Junction Block and Wire Harness (Connector Location)
1B	24	Engine Room Main Wire and Driver Side J/B (Lower Finish Panel)
1C		
1H	25	Instrument Panel Wire and Driver Side J/B (Lower Finish Panel)
5M	28	Instrument Panel Wire and Center J/B LH (Instrument Panel LH)
5N		

□ : Connector Joining Wire Harness and Wire Harness

Code	See Page	Joining Wire Harness and Wire Harness (Connector Location)
EK1	51	Instrument Panel Wire and Floor Wire (Right Kick Panel)
EL1	51	Instrument Panel Wire and Floor No.2 Wire (Left Kick Panel)
IK1	52	Rear Door No.1 Wire and Floor Wire (Right Quarter Panel)
JL1	52	Rear Door No.2 Wire and Floor No.2 Wire (Left Quarter Panel)

▽ : Ground Points

Code	See Page	Ground Points Location
E4	51	Left Kick Panel
I1	52	Access Door RH
J1	52	Access Door LH
K1	52	Floor Seat Crossmember RH
L2	52	Left Quarter Panel

Turn Signal and Hazard Warning Light

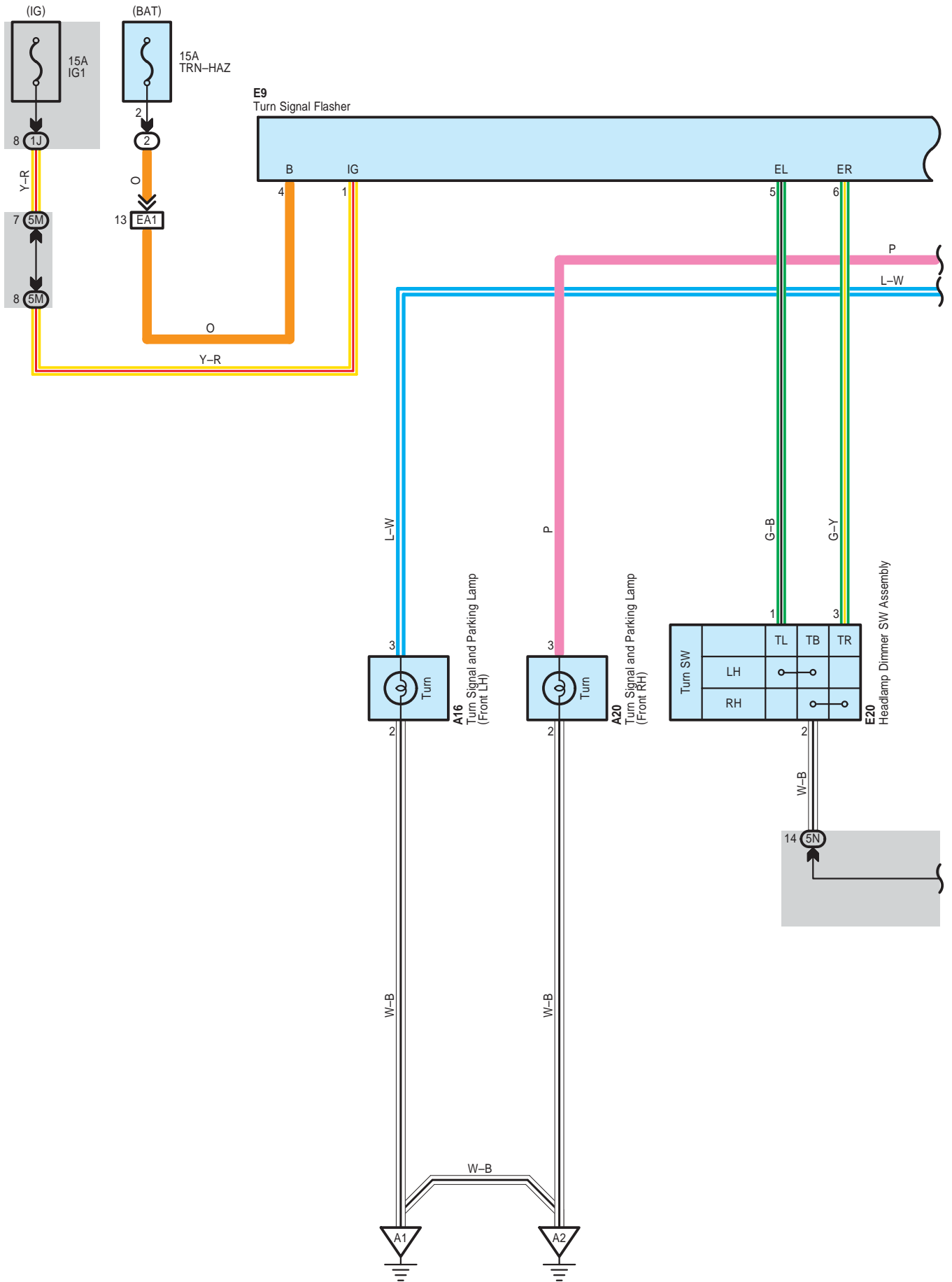

E9
Turn Signal Flasher

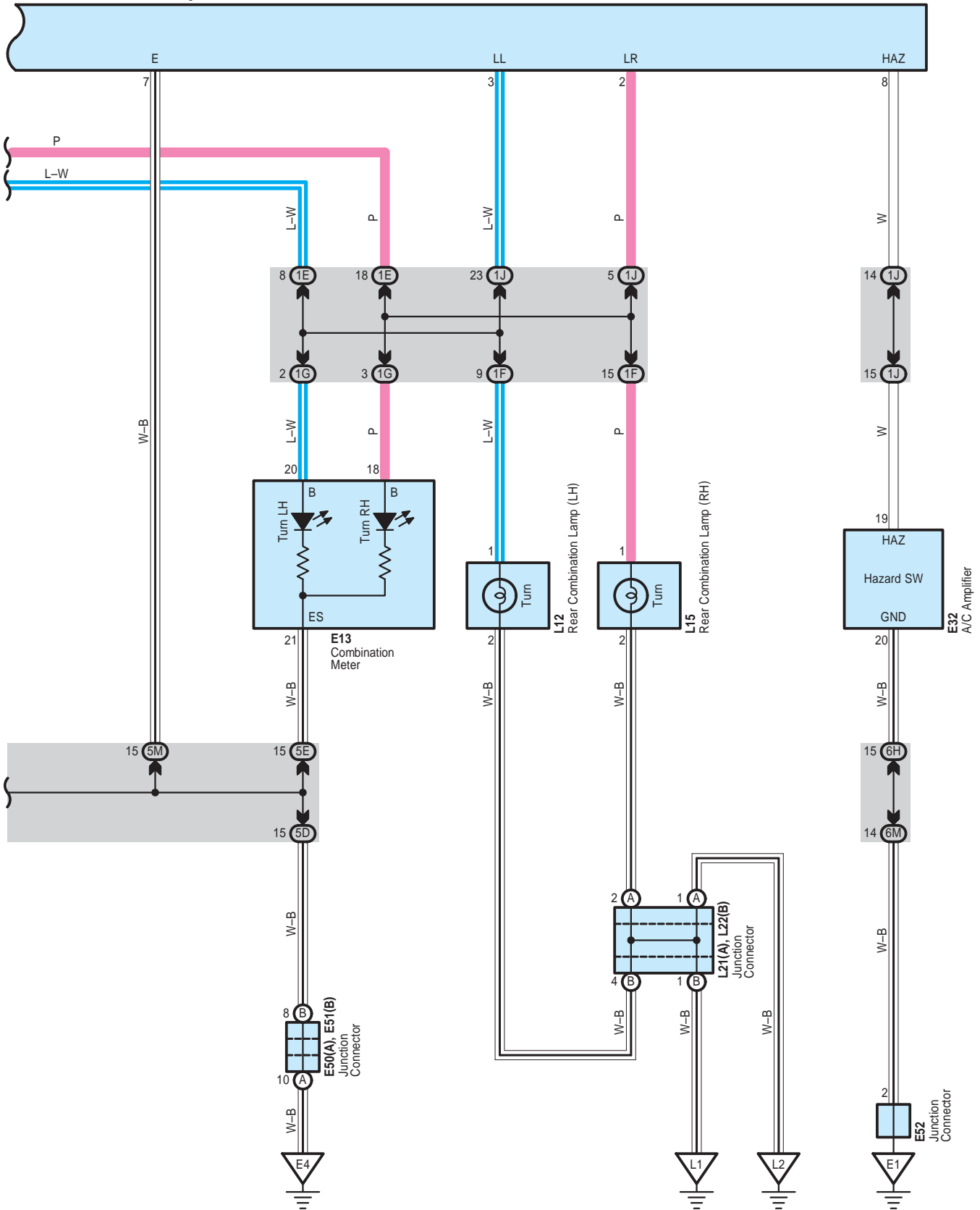

Turn Signal and Hazard Warning Light

○ : Parts Location

Code	See Page	Code	See Page	Code	See Page
A16	38	E32	43	L15	46
A20	38	E50	A 44	L21	A 46
E9	42	E51	B 44	L22	B 46
E13	42	E52	44		
E20	42	L12	46		

○ : Relay Blocks

Code	See Page	Relay Blocks (Relay Block Location)
2	22	Engine Room R/B No.2 (Engine Compartment Left)

○ : Junction Block and Wire Harness Connector

Code	See Page	Junction Block and Wire Harness (Connector Location)
1E	24	Engine Room Main Wire and Driver Side J/B (Lower Finish Panel)
1F	24	Floor No.2 Wire and Driver Side J/B (Lower Finish Panel)
1G	25	Instrument Panel Wire and Driver Side J/B (Lower Finish Panel)
1J		
5D	28	Instrument Panel Wire and Center J/B LH (Instrument Panel LH)
5E		
5M		
5N		
6H	32	Instrument Panel Wire and Center J/B RH (Instrument Panel RH)
6M		

□ : Connector Joining Wire Harness and Wire Harness

Code	See Page	Joining Wire Harness and Wire Harness (Connector Location)
EA1	51	Instrument Panel Wire and Engine Room Main Wire (Left Kick Panel)

▽ : Ground Points

Code	See Page	Ground Points Location
A1	50	Left Fender Apron
A2	50	Right Fender Apron
E1	51	Instrument Panel Brace RH
E4	51	Left Kick Panel
L1	52	Floor Seat Crossmember LH
L2	52	Left Quarter Panel

Interior Light

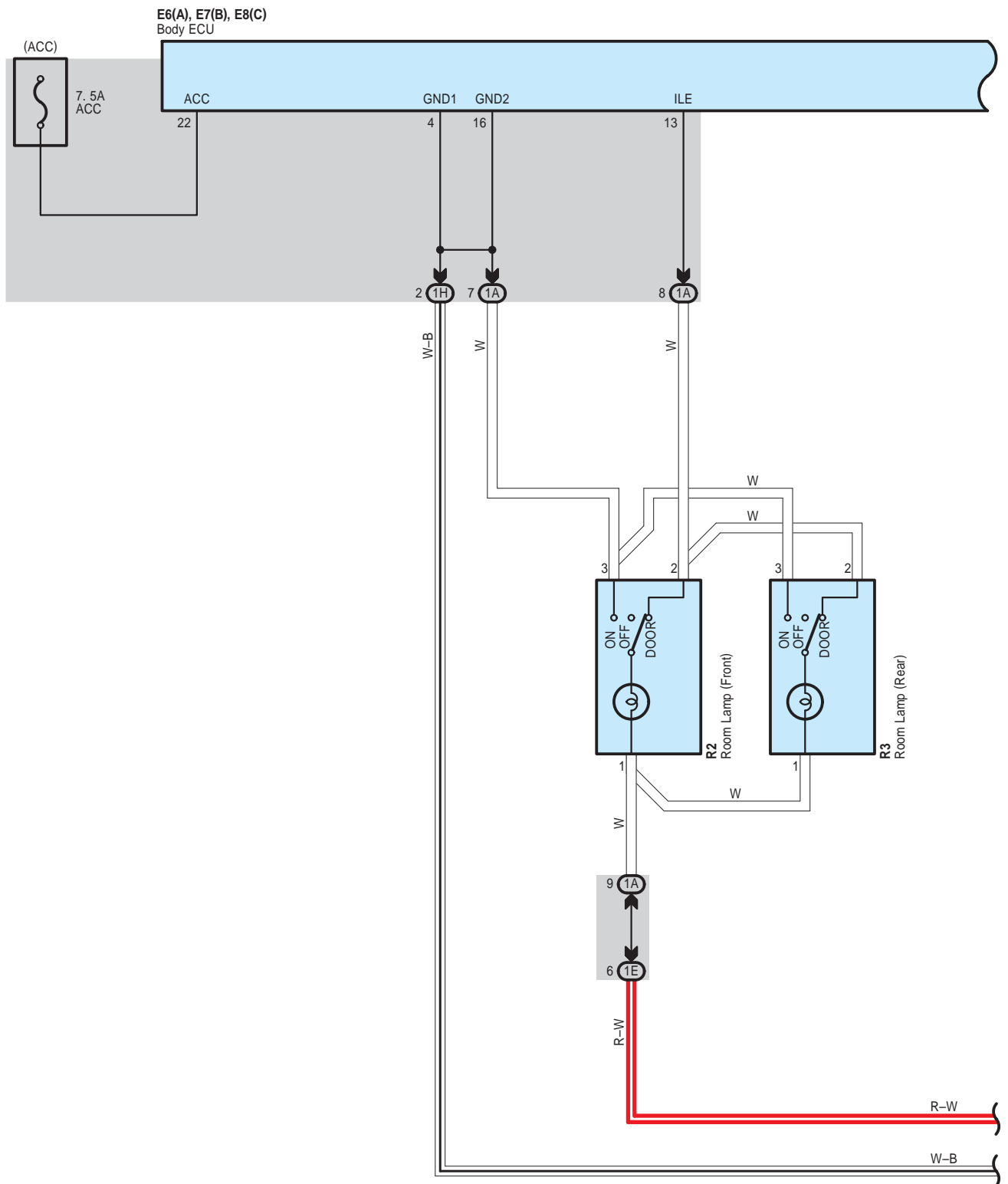

E6(A), E7(B), E8(C)
Body ECU

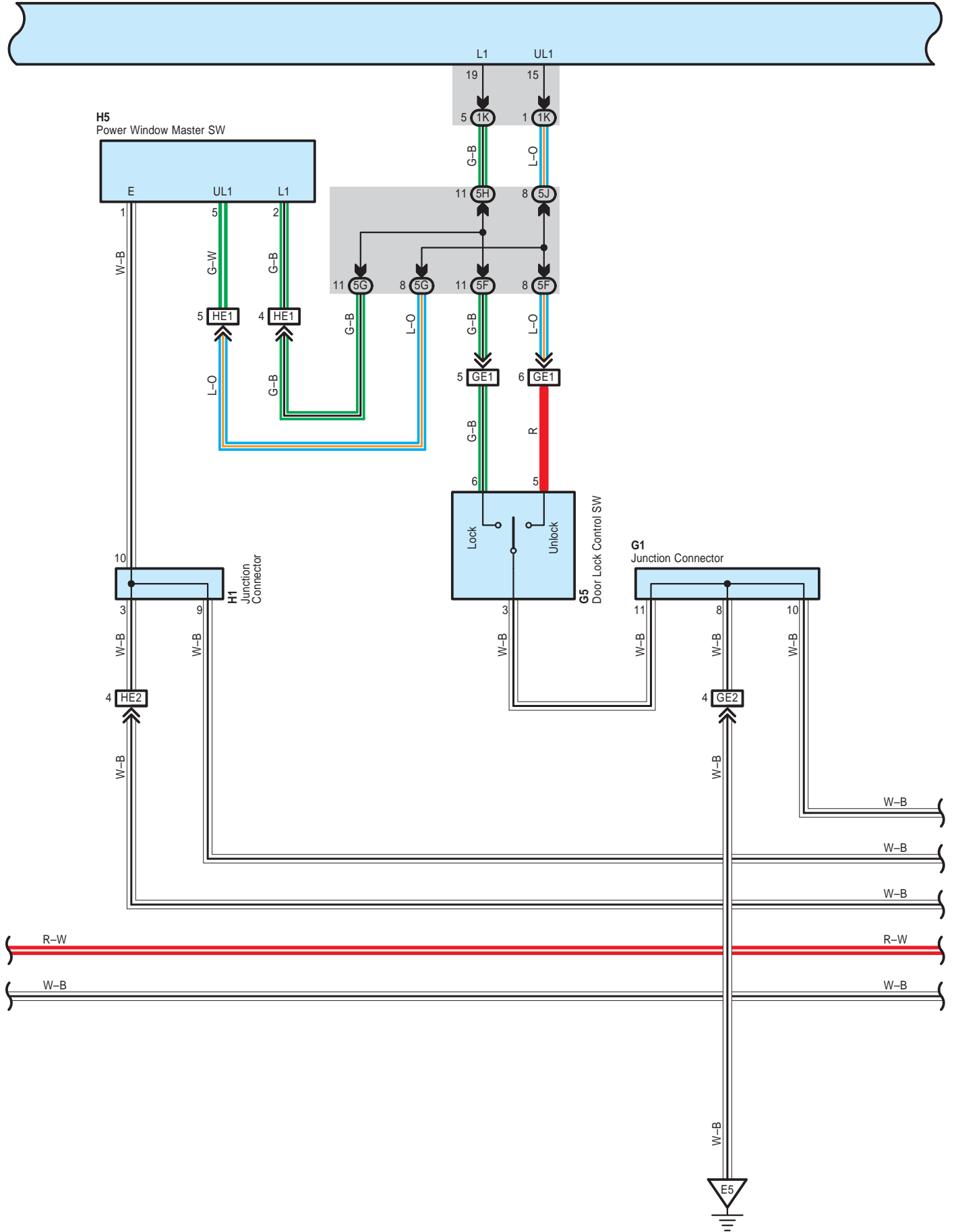

Interior Light

E6(A), E7(B), E8(C)
Body ECU

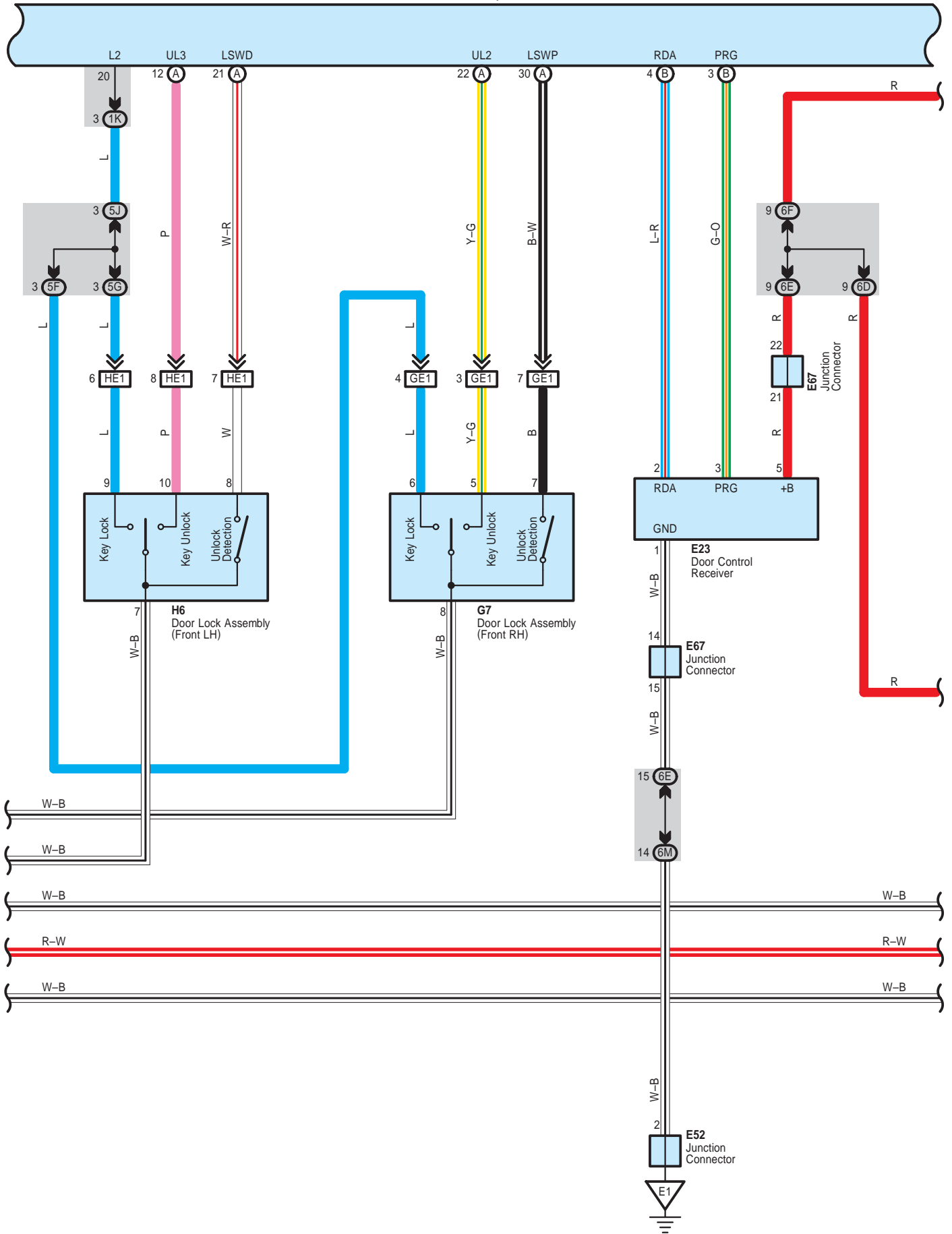

E6(A), E7(B), E8(C)
Body ECU

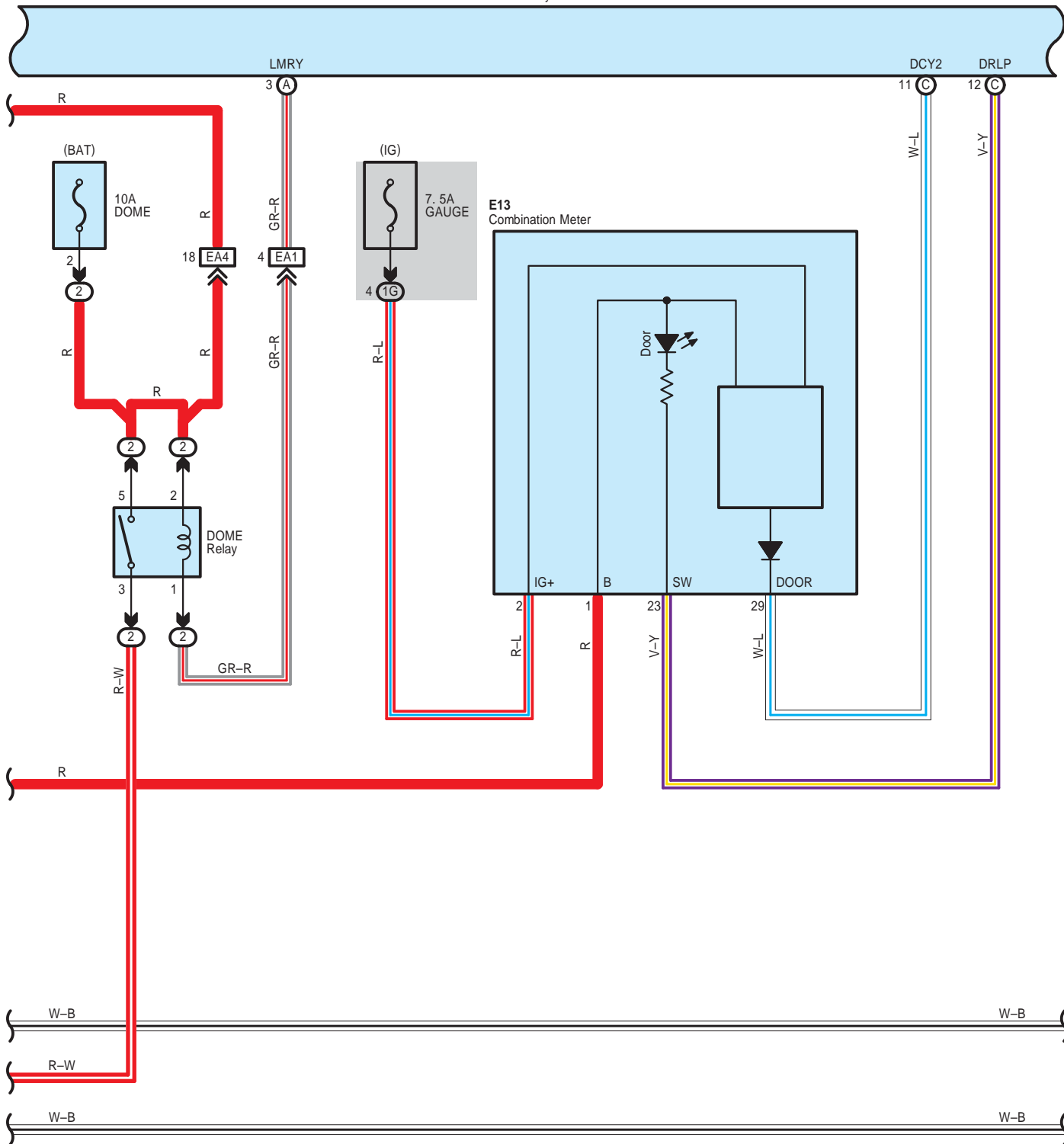

Interior Light

E6(A), E7(B), E8(C)
Body ECU

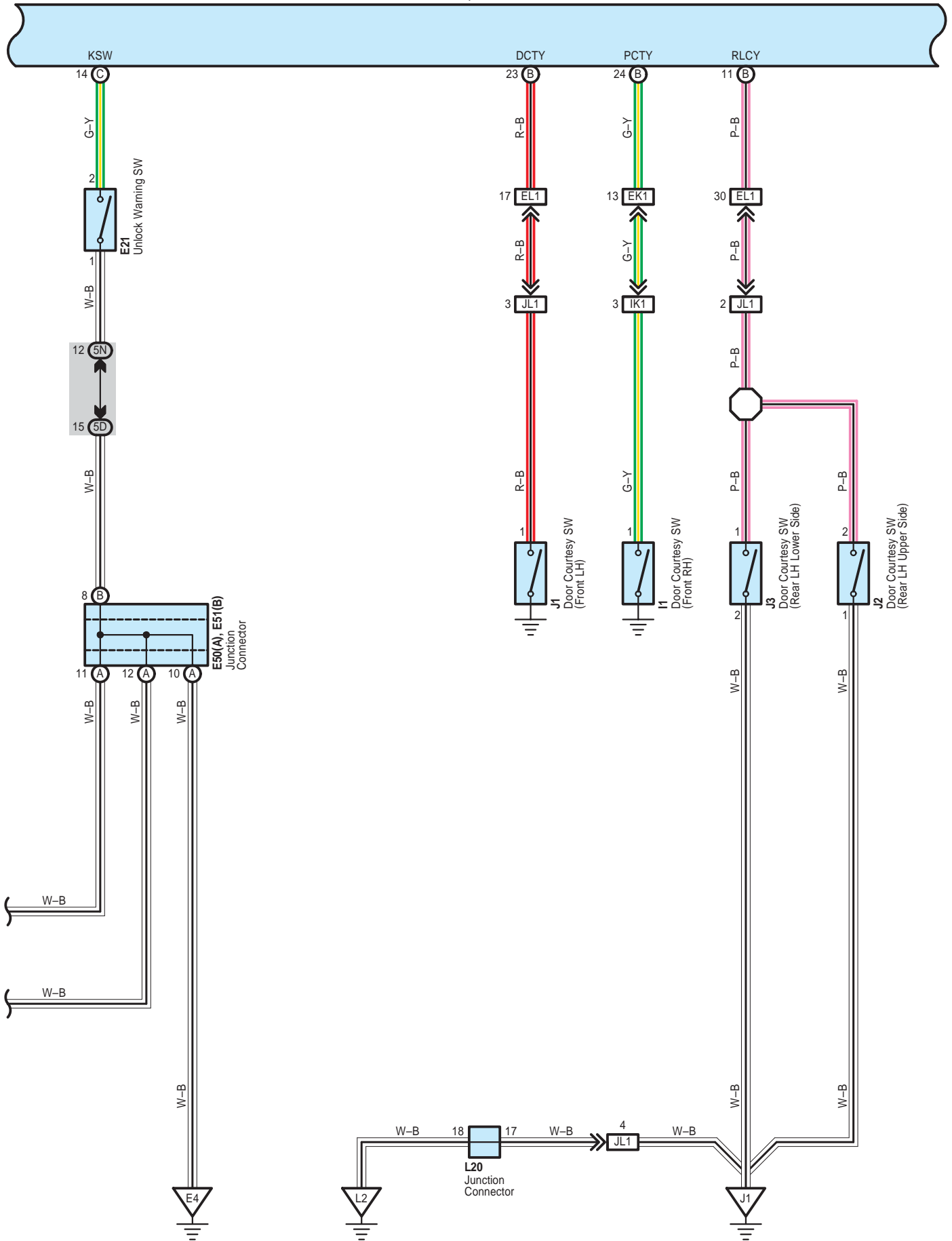

E6(A), E7(B), E8(C)
Body ECU

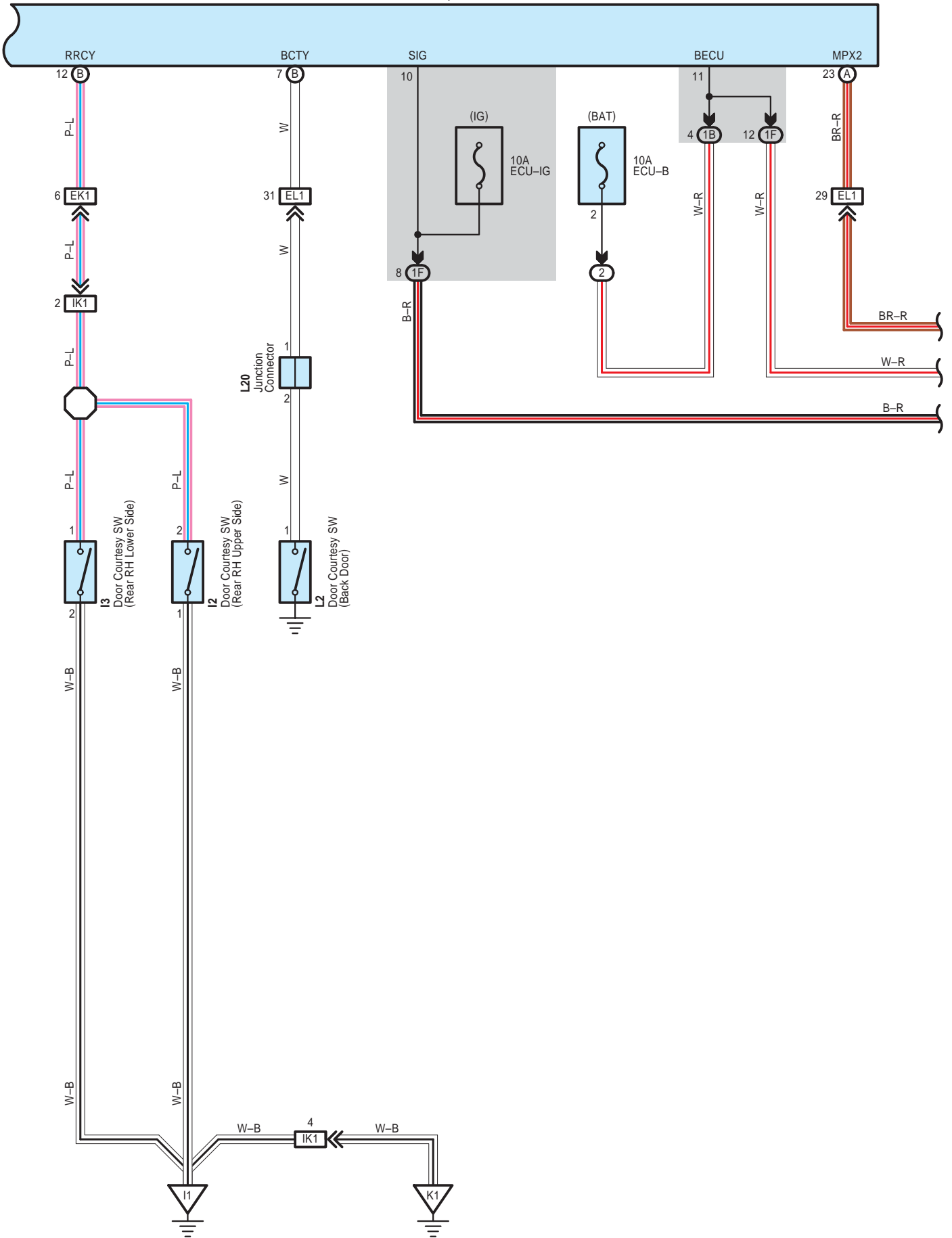

Interior Light

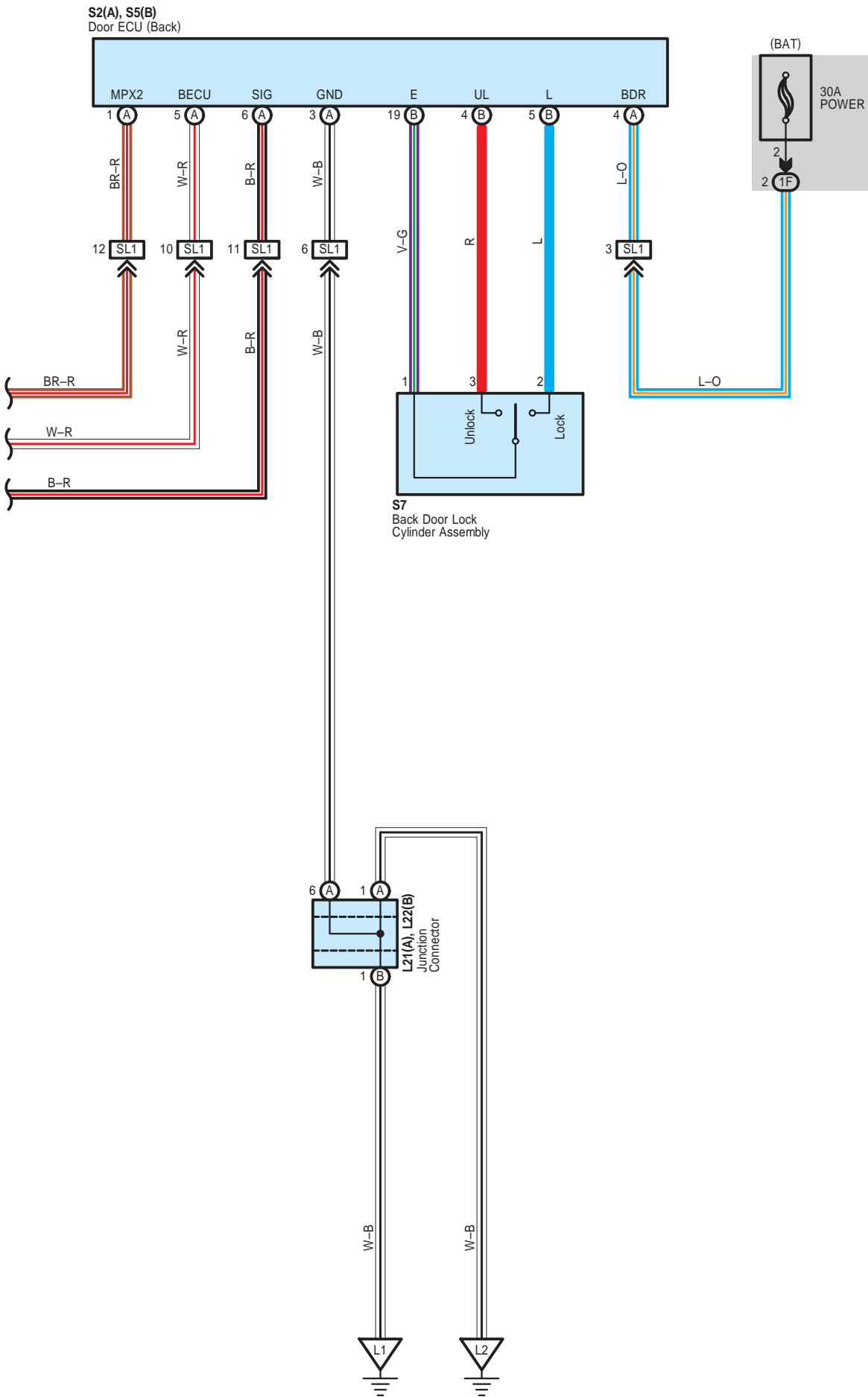

System Outline

The interior light is controlled by the body ECU. This system has following features.

1. Normal Operation

* When one of the doors opened, the room lamps and open door warning light is turned on. When the all doors are closed, the room lamps and open door warning light is turned off.

2. Illuminated Entry System

* When a door is unlocked through a key operation or transmitter operation, or if a door is opened or closed, the illuminated entry system turns ON the room lamps.

* If the ignition SW is turned to the ACC or ON position or if all doors are locked during the 15 seconds in which these lamps are ON, they will immediately turn OFF.

○ : Parts Location

Code	See Page	Code	See Page	Code	See Page		
E6	A	42	G5	47	L2	46	
E7	B	42	G7	47	L20	46	
E8	C	42	H1	47	L21	A	46
E13		42	H5	47	L22	B	46
E21		42	H6	47	R2		47
E23		42	I1	47	R3		47
E50	A	44	I2	47	S2	A	47
E51	B	44	I3	47	S5	B	47
E52		44	J1	47	S7		47
E67		44	J2	47			
G1		47	J3	47			

○ : Relay Blocks

Code	See Page	Relay Blocks (Relay Block Location)
2	22	Engine Room R/B No.2 (Engine Compartment Left)

○ : Junction Block and Wire Harness Connector

Code	See Page	Junction Block and Wire Harness (Connector Location)
1A	24	Roof Wire and Driver Side J/B (Lower Finish Panel)
1B	24	Engine Room Main Wire and Driver Side J/B (Lower Finish Panel)
1E		
1F		
1G	25	Instrument Panel Wire and Driver Side J/B (Lower Finish Panel)
1H		
1K		
5D		
5F	28	Instrument Panel Wire and Center J/B LH (Instrument Panel LH)
5G		
5H		
5J		
5N		
6D	32	Instrument Panel Wire and Center J/B RH (Instrument Panel RH)
6E		
6F		
6M		

Interior Light

 : Connector Joining Wire Harness and Wire Harness

Code	See Page	Joining Wire Harness and Wire Harness (Connector Location)
EA1	51	Instrument Panel Wire and Engine Room Main Wire (Left Kick Panel)
EA4		
EK1	51	Instrument Panel Wire and Floor Wire (Right Kick Panel)
EL1	51	Instrument Panel Wire and Floor No.2 Wire (Left Kick Panel)
GE1	51	Front Door RH Wire and Instrument Panel Wire (Right Kick Panel)
GE2		
HE1	51	Front Door LH Wire and Instrument Panel Wire (Left Kick Panel)
HE2		
IK1	52	Rear Door No.1 Wire and Floor Wire (Right Quarter Panel)
JL1	52	Rear Door No.2 Wire and Floor No.2 Wire (Left Quarter Panel)
SL1	52	Back Door No.1 Wire and Floor No.2 Wire (Left Quarter Panel)

 : Ground Points

Code	See Page	Ground Points Location
E1	51	Instrument Panel Brace RH
E4	51	Left Kick Panel
E5	51	Right Kick Panel
I1	52	Access Door RH
J1	52	Access Door LH
K1	52	Floor Seat Crossmember RH
L1	52	Floor Seat Crossmember LH
L2	52	Left Quarter Panel

Taillight and Illumination

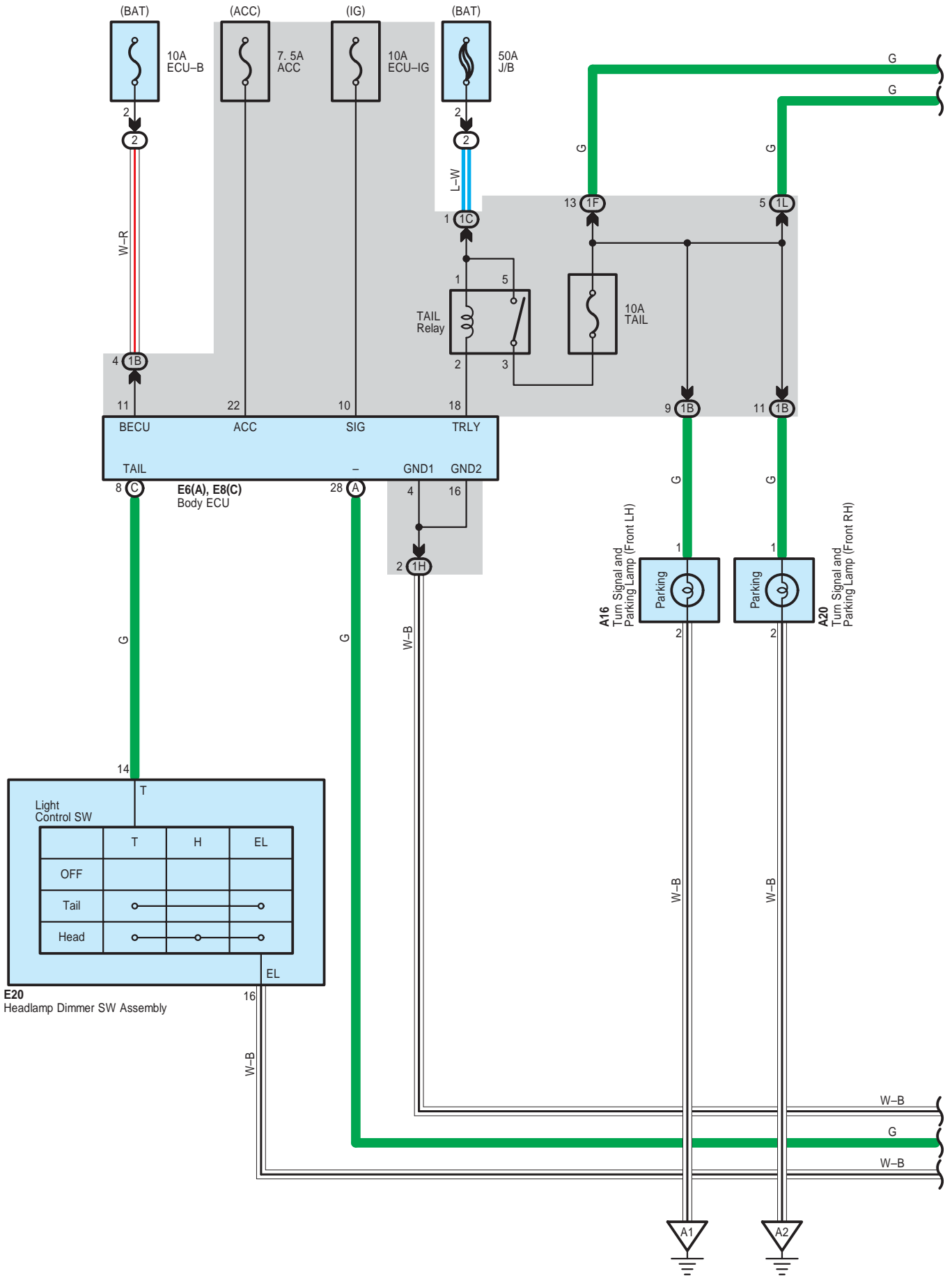

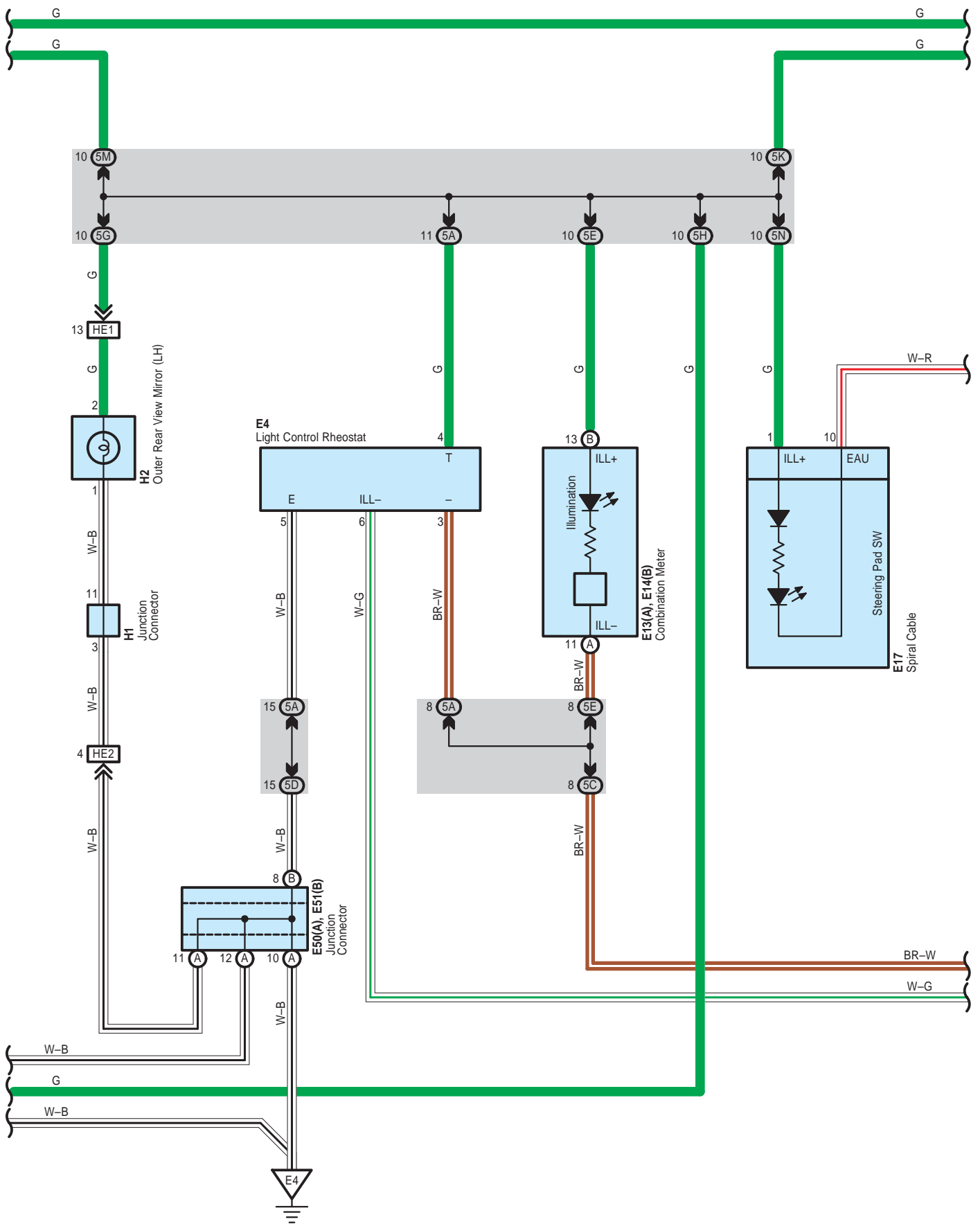

Taillight and Illumination

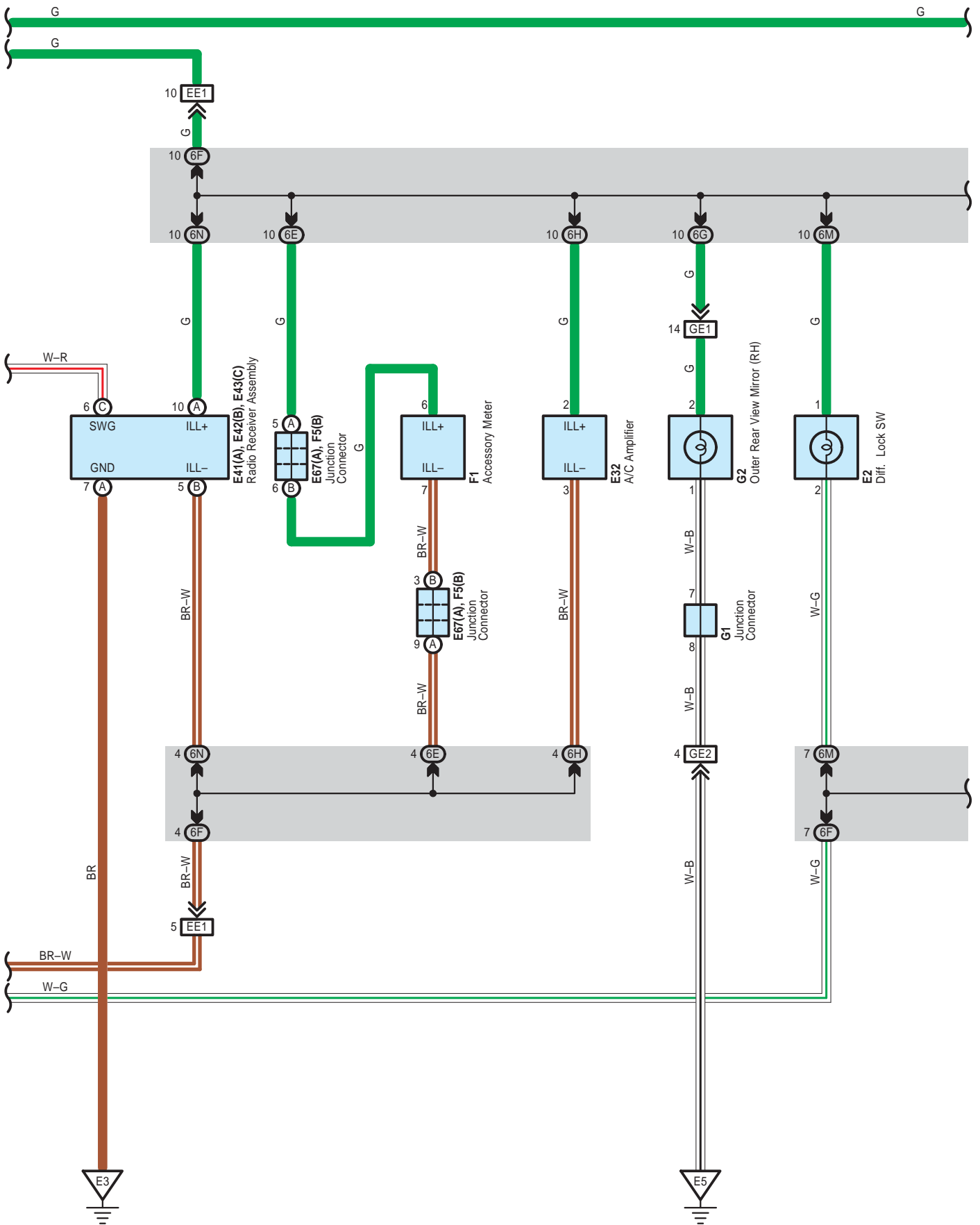

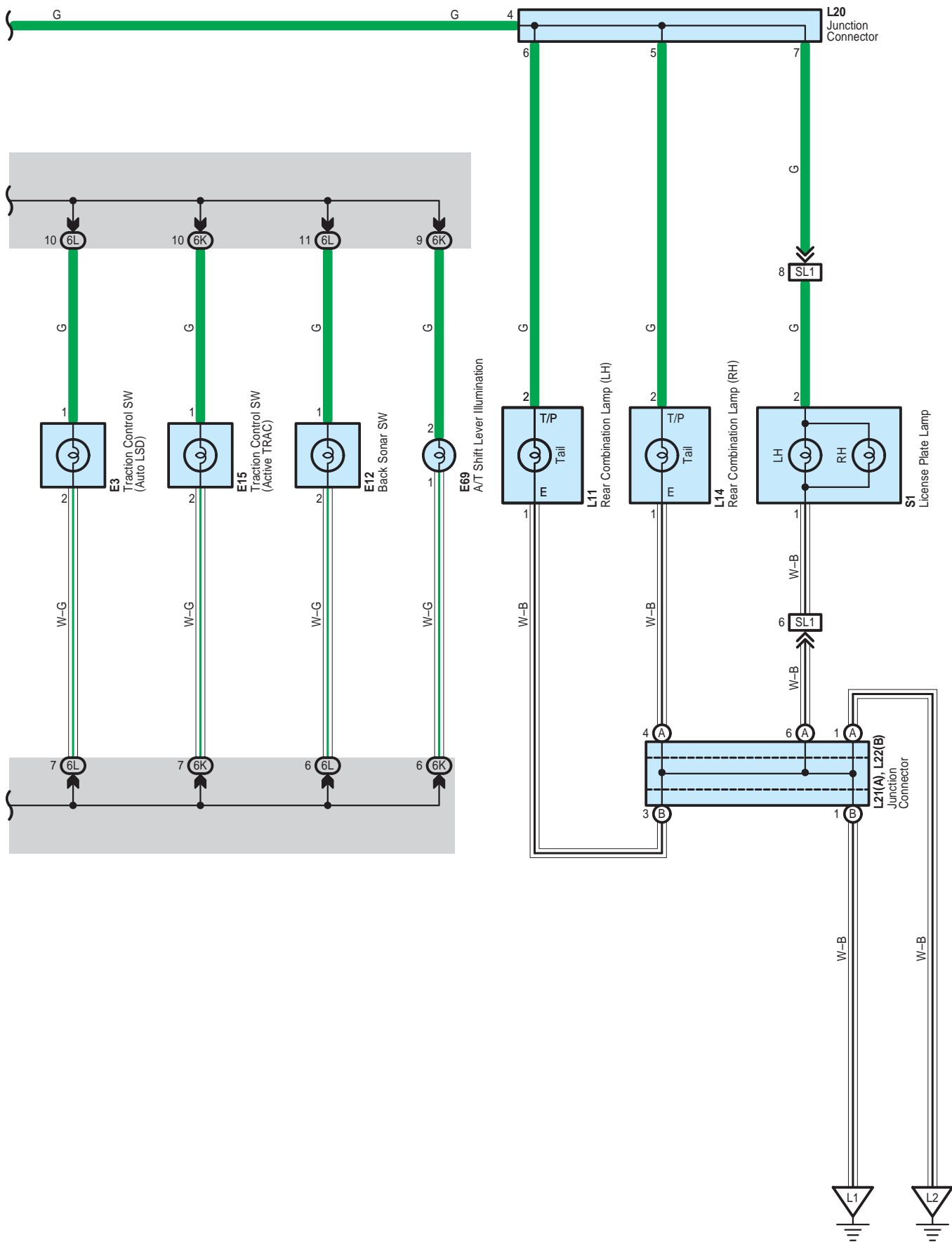

FJ CRUISER (EM0240U)

Taillight and Illumination

○ : Parts Location

Code	See Page	Code	See Page	Code	See Page
A16	38	E17	42	F5	B 45
A20	38	E20	42	G1	47
E2	42	E32	43	G2	47
E3	42	E41	A 43	H1	47
E4	42	E42	B 43	H2	47
E6	A 42	E43	C 43	L11	46
E8	C 42	E50	A 44	L14	46
E12	42	E51	B 44	L20	46
E13	A 42	E67	A 44	L21	A 46
E14	B 42	E69	44	L22	B 46
E15	42	F1	45	S1	47

○ : Relay Blocks

Code	See Page	Relay Blocks (Relay Block Location)
2	22	Engine Room R/B No.2 (Engine Compartment Left)

○ : Junction Block and Wire Harness Connector

Code	See Page	Junction Block and Wire Harness (Connector Location)
1B	24	Engine Room Main Wire and Driver Side J/B (Lower Finish Panel)
1C		
1F	24	Floor No.2 Wire and Driver Side J/B (Lower Finish Panel)
1H	25	Instrument Panel Wire and Driver Side J/B (Lower Finish Panel)
1L		
5A	28	Instrument Panel Wire and Center J/B LH (Instrument Panel LH)
5C		
5D		
5E		
5G		
5H		
5K		
5M		
5N		
6E	32	Instrument Panel Wire and Center J/B RH (Instrument Panel RH)
6F		
6G		
6H		
6K		
6L		
6M		
6N		

□ : Connector Joining Wire Harness and Wire Harness

Code	See Page	Joining Wire Harness and Wire Harness (Connector Location)
EE1	51	Instrument Panel Wire and Instrument Panel Wire (Instrument Panel RH)
GE1	51	Front Door RH Wire and Instrument Panel Wire (Right Kick Panel)
GE2		
HE1	51	Front Door LH Wire and Instrument Panel Wire (Left Kick Panel)
HE2		
SL1	52	Back Door No.1 Wire and Floor No.2 Wire (Left Quarter Panel)



: Ground Points

Code	See Page	Ground Points Location
A1	50	Left Fender Apron
A2	50	Right Fender Apron
E3	51	Instrument Panel Brace RH
E4	51	Left Kick Panel
E5	51	Right Kick Panel
L1	52	Floor Seat Crossmember LH
L2	52	Left Quarter Panel

Stop Light

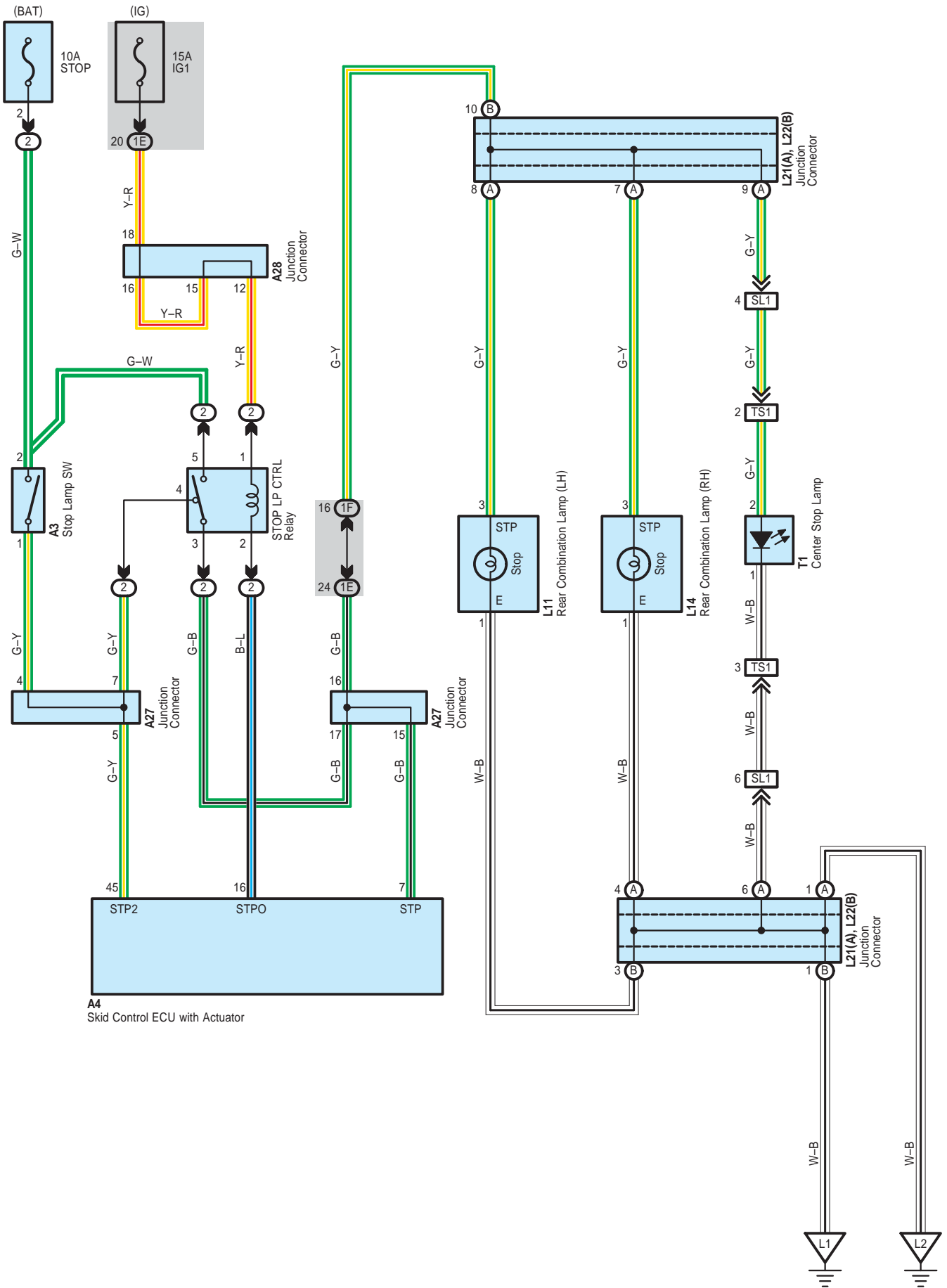

 : **Parts Location**

Code	See Page	Code	See Page	Code	See Page
A3	45	A28	38	L21	A 46
A4	38	L11	46	L22	B 46
A27	45	L14	46	T1	47

 : **Relay Blocks**

Code	See Page	Relay Blocks (Relay Block Location)
2	22	Engine Room R/B No.2 (Engine Compartment Left)

 : **Junction Block and Wire Harness Connector**

Code	See Page	Junction Block and Wire Harness (Connector Location)
1E	24	Engine Room Main Wire and Driver Side J/B (Lower Finish Panel)
1F	24	Floor No.2 Wire and Driver Side J/B (Lower Finish Panel)

 : **Connector Joining Wire Harness and Wire Harness**

Code	See Page	Joining Wire Harness and Wire Harness (Connector Location)
SL1	52	Back Door No.1 Wire and Floor No.2 Wire (Left Quarter Panel)
TS1	52	Back Door No.2 Wire and Back Door No.1 Wire (Left Side of Back Door)

 : **Ground Points**

Code	See Page	Ground Points Location
L1	52	Floor Seat Crossmember LH
L2	52	Left Quarter Panel

Back-Up Light

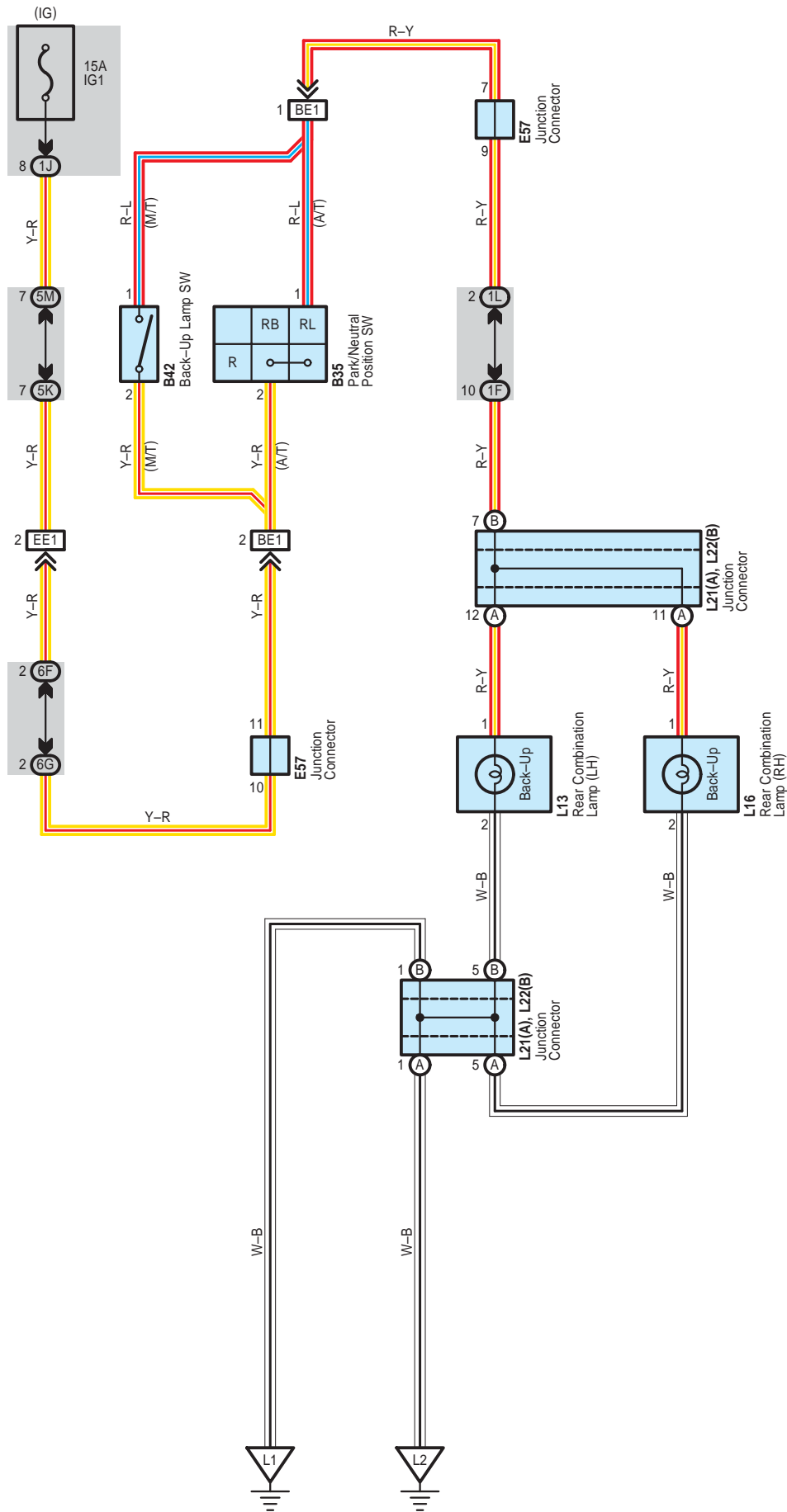

 : **Parts Location**

Code	See Page	Code	See Page	Code	See Page
B35	40	L13	46	L22	B 46
B42	40	L16	46		
E57	44	L21	A 46		

 : **Junction Block and Wire Harness Connector**

Code	See Page	Junction Block and Wire Harness (Connector Location)
1F	24	Floor No.2 Wire and Driver Side J/B (Lower Finish Panel)
1J	25	Instrument Panel Wire and Driver Side J/B (Lower Finish Panel)
1L		
5K	28	Instrument Panel Wire and Center J/B LH (Instrument Panel LH)
5M		
6F	32	Instrument Panel Wire and Center J/B RH (Instrument Panel RH)
6G		

 : **Connector Joining Wire Harness and Wire Harness**

Code	See Page	Joining Wire Harness and Wire Harness (Connector Location)
BE1	51	Engine Wire and Instrument Panel Wire (Upper the Glove Box)
EE1	51	Instrument Panel Wire and Instrument Panel Wire (Instrument Panel RH)

 : **Ground Points**

Code	See Page	Ground Points Location
L1	52	Floor Seat Crossmember LH
L2	52	Left Quarter Panel

Key Reminder

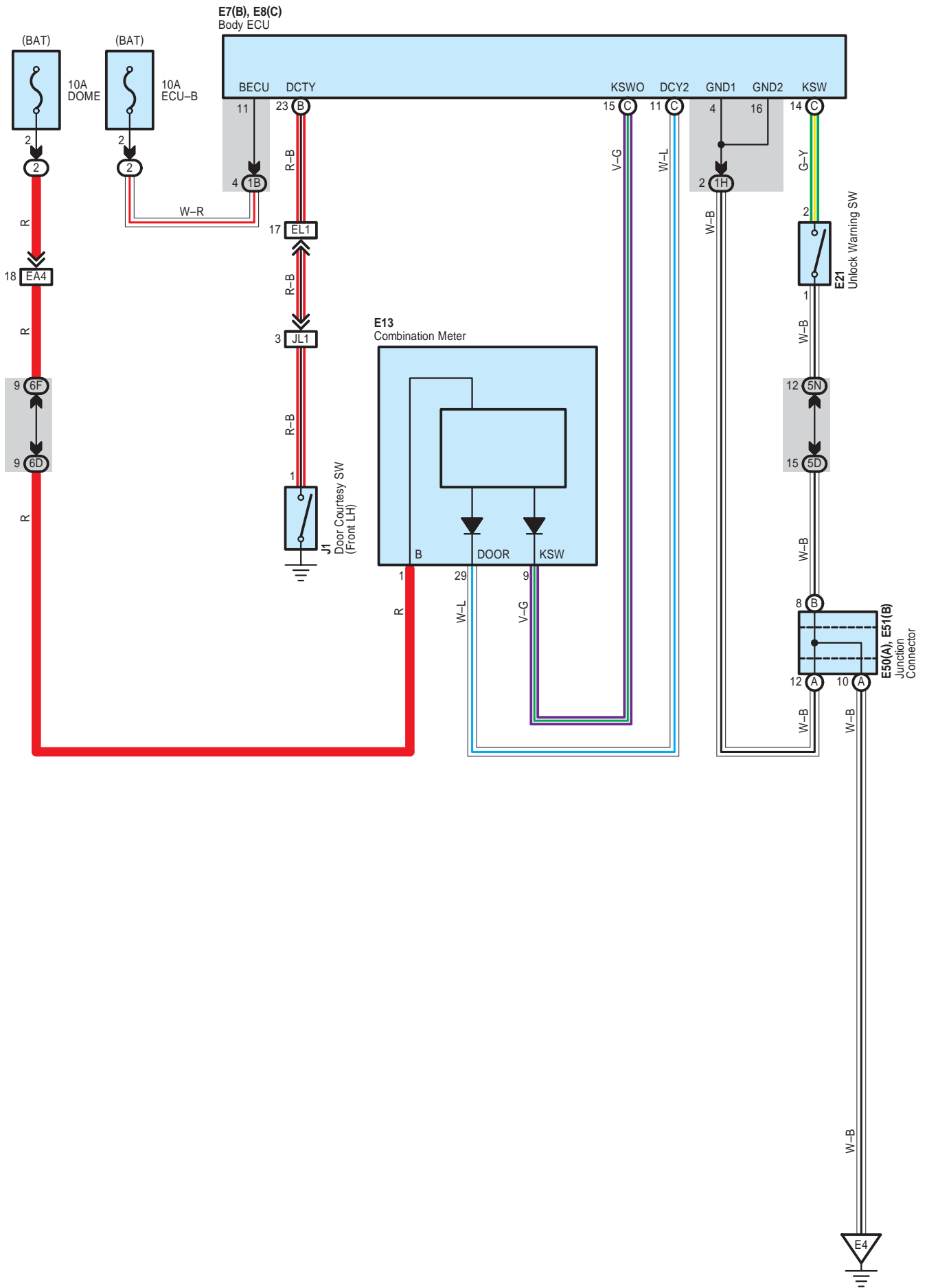

System Outline

With the ignition key inserted in the key cylinder (Unlock warning SW on), the ignition SW still off and driver's door open (Door courtesy SW on), when a signal is input to the combination meter, the combination meter operates key reminder buzzer sounds.

○ : Parts Location

Code		See Page	Code		See Page	Code		See Page
E7	B	42	E21		42	J1	47	
E8	C	42	E50	A	44			
E13		42	E51	B	44			

○ : Relay Blocks

Code	See Page	Relay Blocks (Relay Block Location)
2	22	Engine Room R/B No.2 (Engine Compartment Left)

○ : Junction Block and Wire Harness Connector

Code	See Page	Junction Block and Wire Harness (Connector Location)
1B	24	Engine Room Main Wire and Driver Side J/B (Lower Finish Panel)
1H	25	Instrument Panel Wire and Driver Side J/B (Lower Finish Panel)
5D	28	Instrument Panel Wire and Center J/B LH (Instrument Panel LH)
5N		
6D	32	Instrument Panel Wire and Center J/B RH (Instrument Panel RH)
6F		

□ : Connector Joining Wire Harness and Wire Harness

Code	See Page	Joining Wire Harness and Wire Harness (Connector Location)
EA4	51	Instrument Panel Wire and Engine Room Main Wire (Left Kick Panel)
EL1	51	Instrument Panel Wire and Floor No.2 Wire (Left Kick Panel)
JL1	52	Rear Door No.2 Wire and Floor No.2 Wire (Left Quarter Panel)

▽ : Ground Points

Code	See Page	Ground Points Location
E4	51	Left Kick Panel

Seat Belt Warning

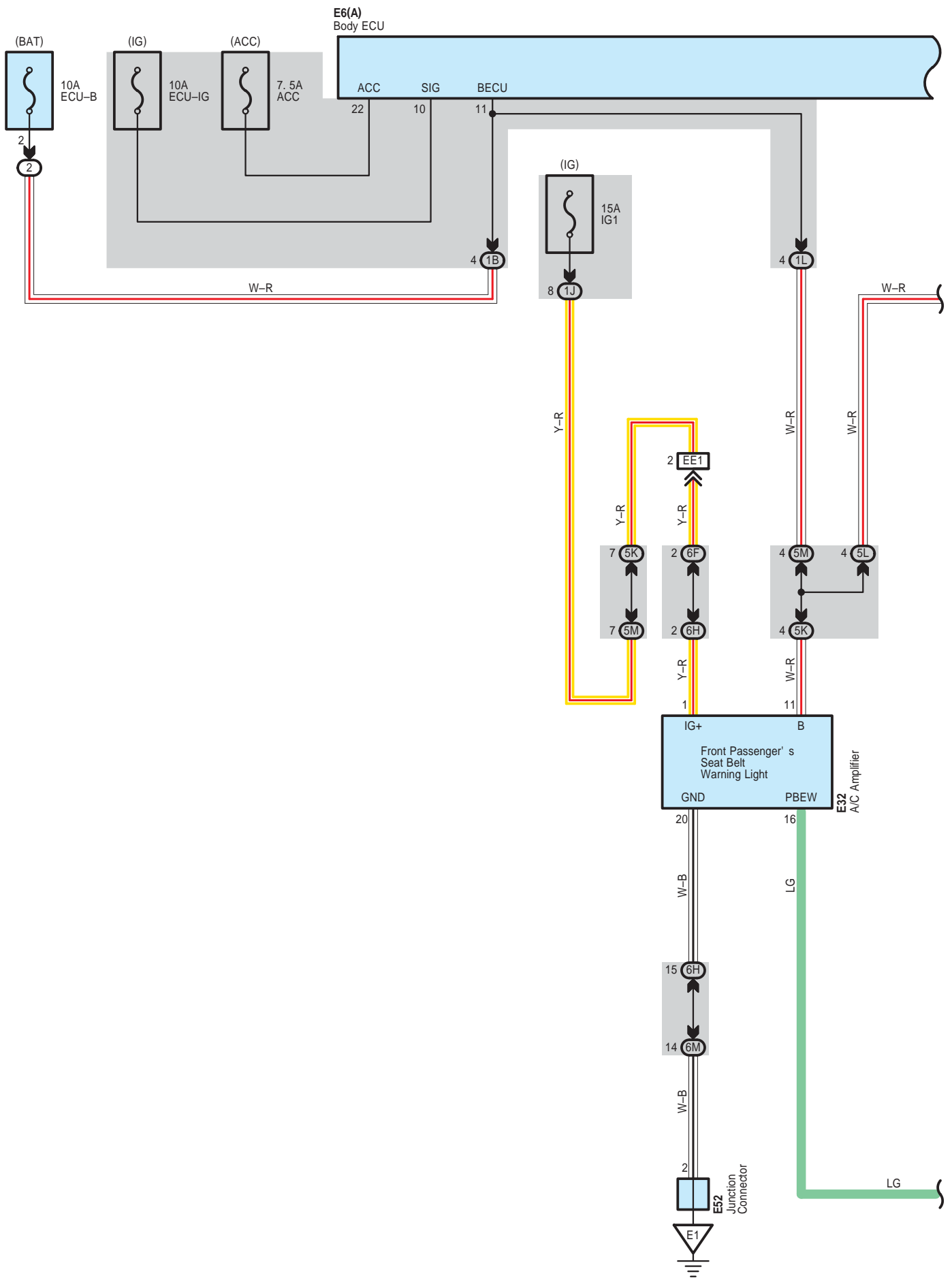

E6(A)
Body ECU

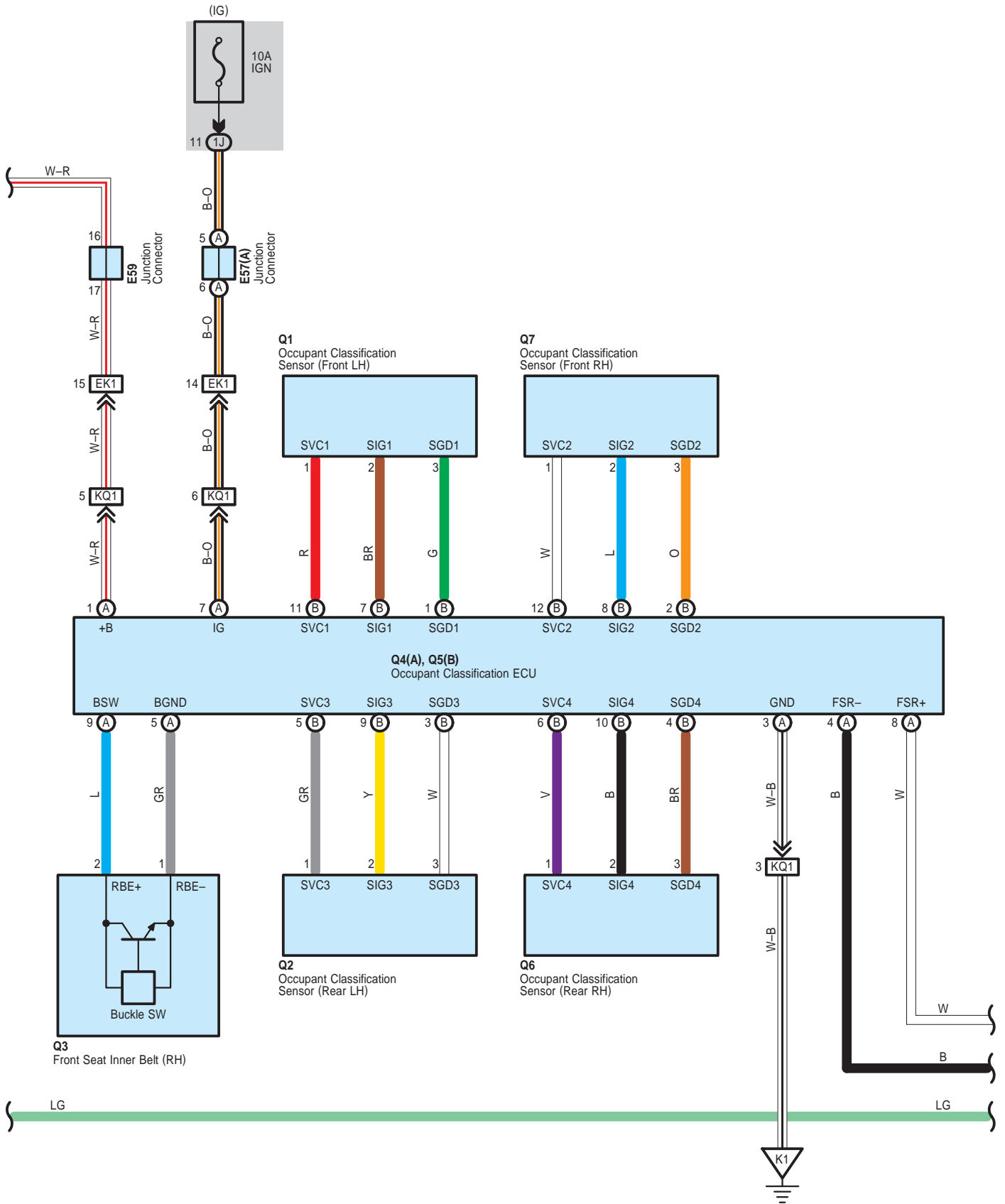

Seat Belt Warning

E6(A)
Body ECU

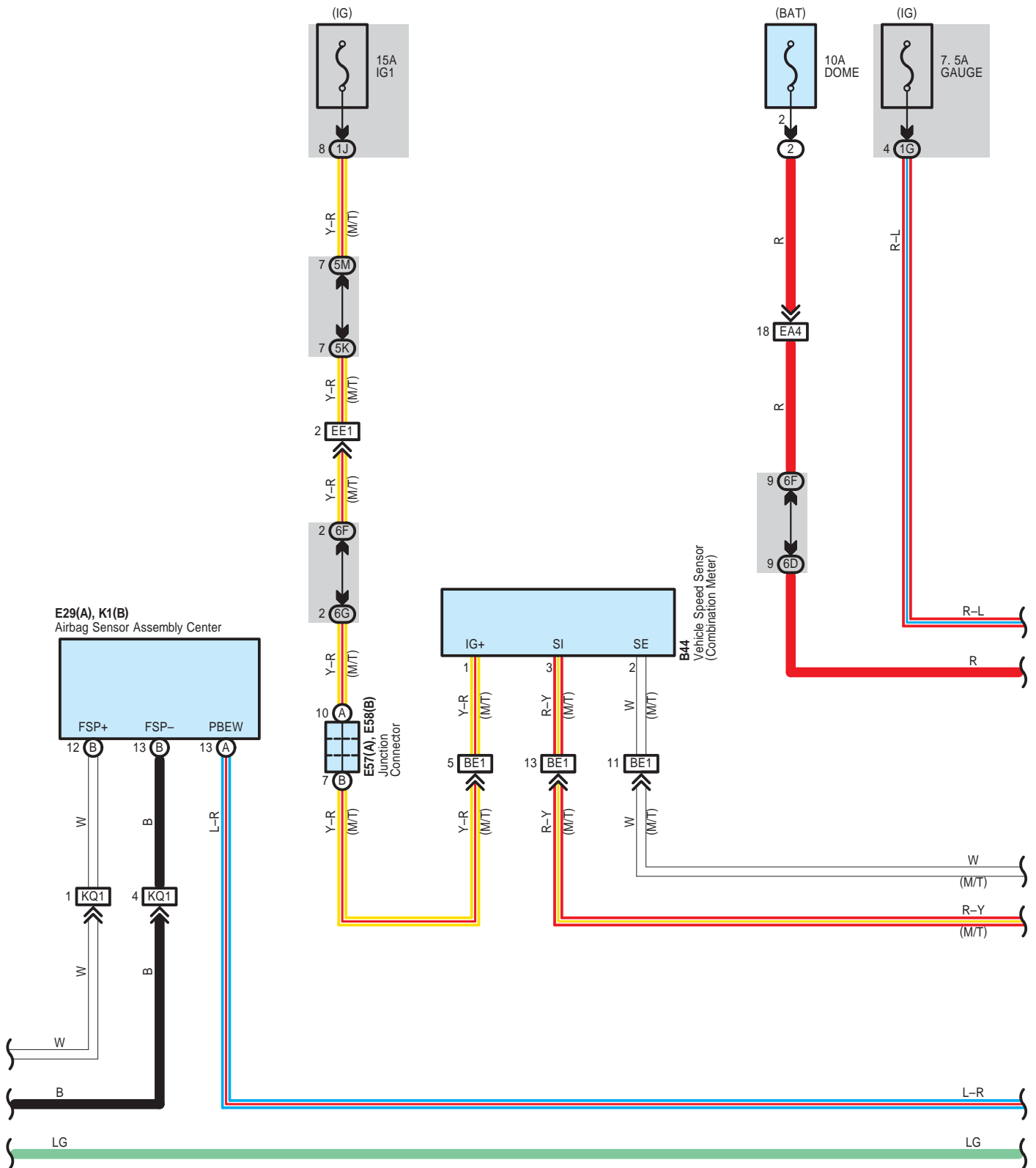

E6(A)
Body ECU

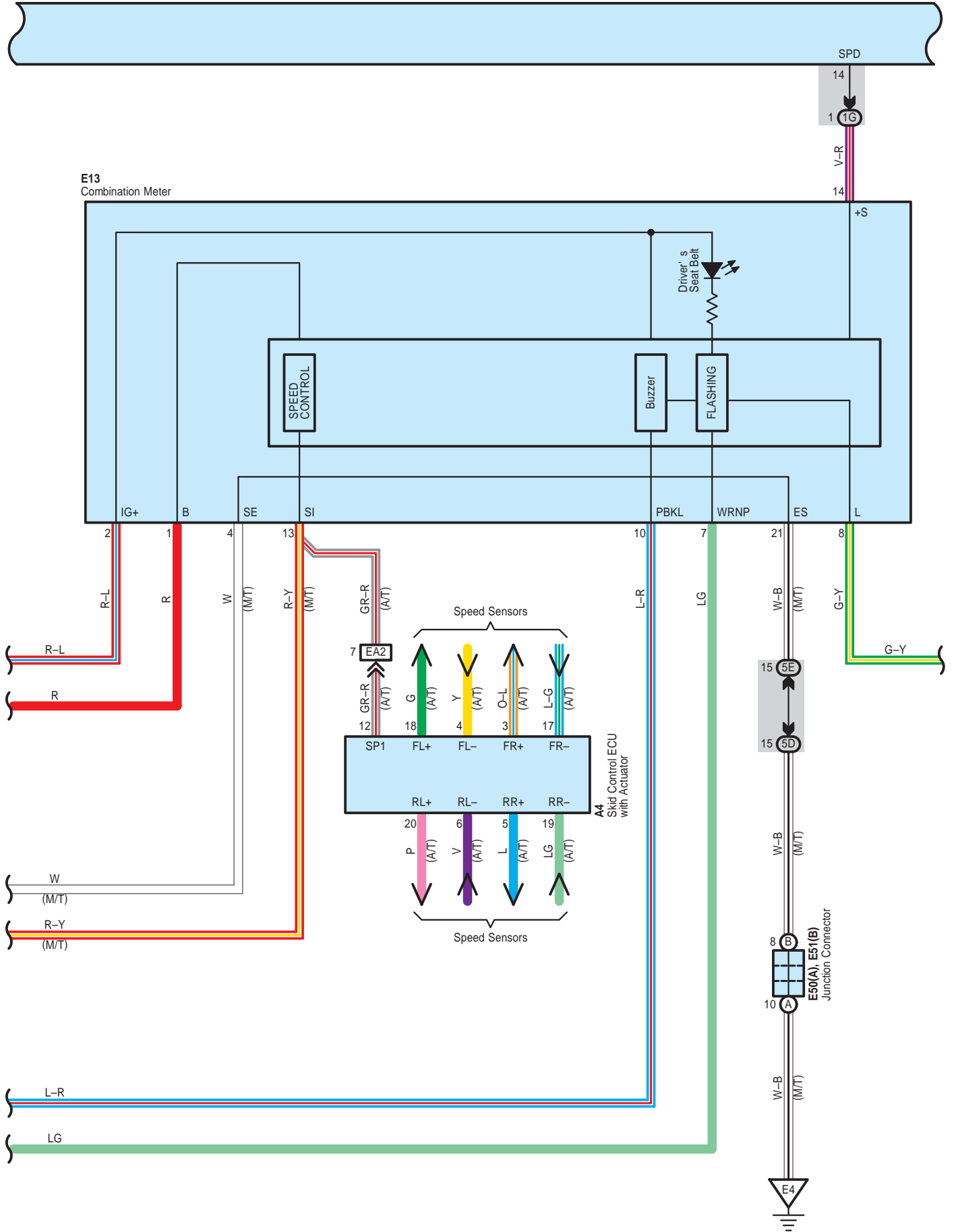

Seat Belt Warning

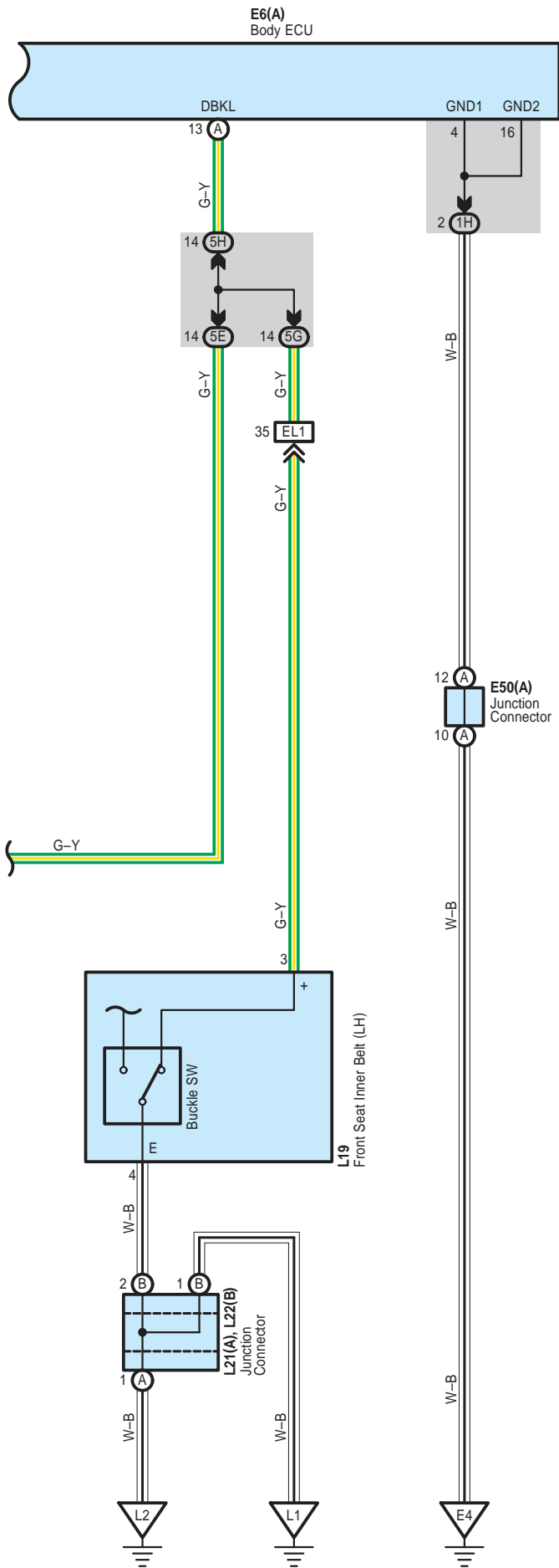

System Outline

When the driver has not fastened the seat belt while the ignition SW is ON, the driver seat belt warning light blinks, and a warning buzzer comes on.

Also, in the front passenger seat, a sensor recognizes passenger, and when the passenger has not fastened the seat belt, the front passenger seat belt warning light blinks.

: Parts Location

Code	See Page	Code	See Page	Code	See Page
A4	38	E52	44	Q1	48
B44	40	E57	A 44	Q2	48
E6	A 42	E58	B 44	Q3	48
E13	42	E59	44	Q4	A 48
E29	A 43	K1	B 45	Q5	B 48
E32	43	L19	48	Q6	48
E50	A 44	L21	A 46	Q7	48
E51	B 44	L22	B 46		

: Relay Blocks

Code	See Page	Relay Blocks (Relay Block Location)
2	22	Engine Room R/B No.2 (Engine Compartment Left)

: Junction Block and Wire Harness Connector

Code	See Page	Junction Block and Wire Harness (Connector Location)
1B	24	Engine Room Main Wire and Driver Side J/B (Lower Finish Panel)
1G	25	Instrument Panel Wire and Driver Side J/B (Lower Finish Panel)
1H		
1J		
1L		
5D	28	Instrument Panel Wire and Center J/B LH (Instrument Panel LH)
5E		
5G		
5H		
5K		
5L		
5M	32	Instrument Panel Wire and Center J/B RH (Instrument Panel RH)
6D		
6F		
6G		
6H		
6M		

: Connector Joining Wire Harness and Wire Harness

Code	See Page	Joining Wire Harness and Wire Harness (Connector Location)
BE1	51	Engine Wire and Instrument Panel Wire (Upper the Glove Box)
EA2	51	Instrument Panel Wire and Engine Room Main Wire (Left Kick Panel)
EA4		
EE1	51	Instrument Panel Wire and Instrument Panel Wire (Instrument Panel RH)
EK1	51	Instrument Panel Wire and Floor Wire (Right Kick Panel)
EL1	51	Instrument Panel Wire and Floor No.2 Wire (Left Kick Panel)
KQ1	53	Floor Wire and Seat No.1 Wire (Under the Front Seat RH)

Seat Belt Warning



: **Ground Points**

Code	See Page	Ground Points Location
E1	51	Instrument Panel Brace RH
E4	51	Left Kick Panel
K1	52	Floor Seat Crossmember RH
L1	52	Floor Seat Crossmember LH
L2	52	Left Quarter Panel

Front Wiper and Washer

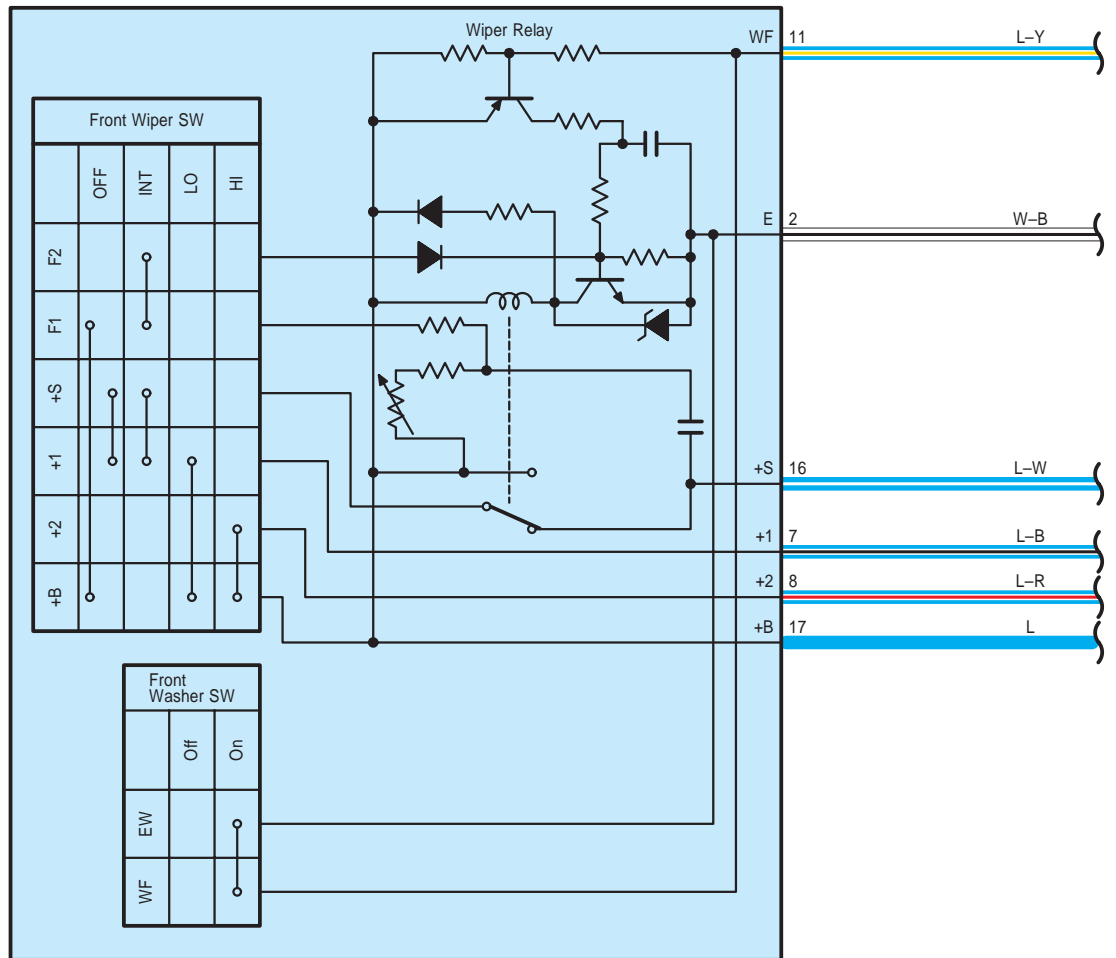

E19
Windshield Wiper SW Assembly

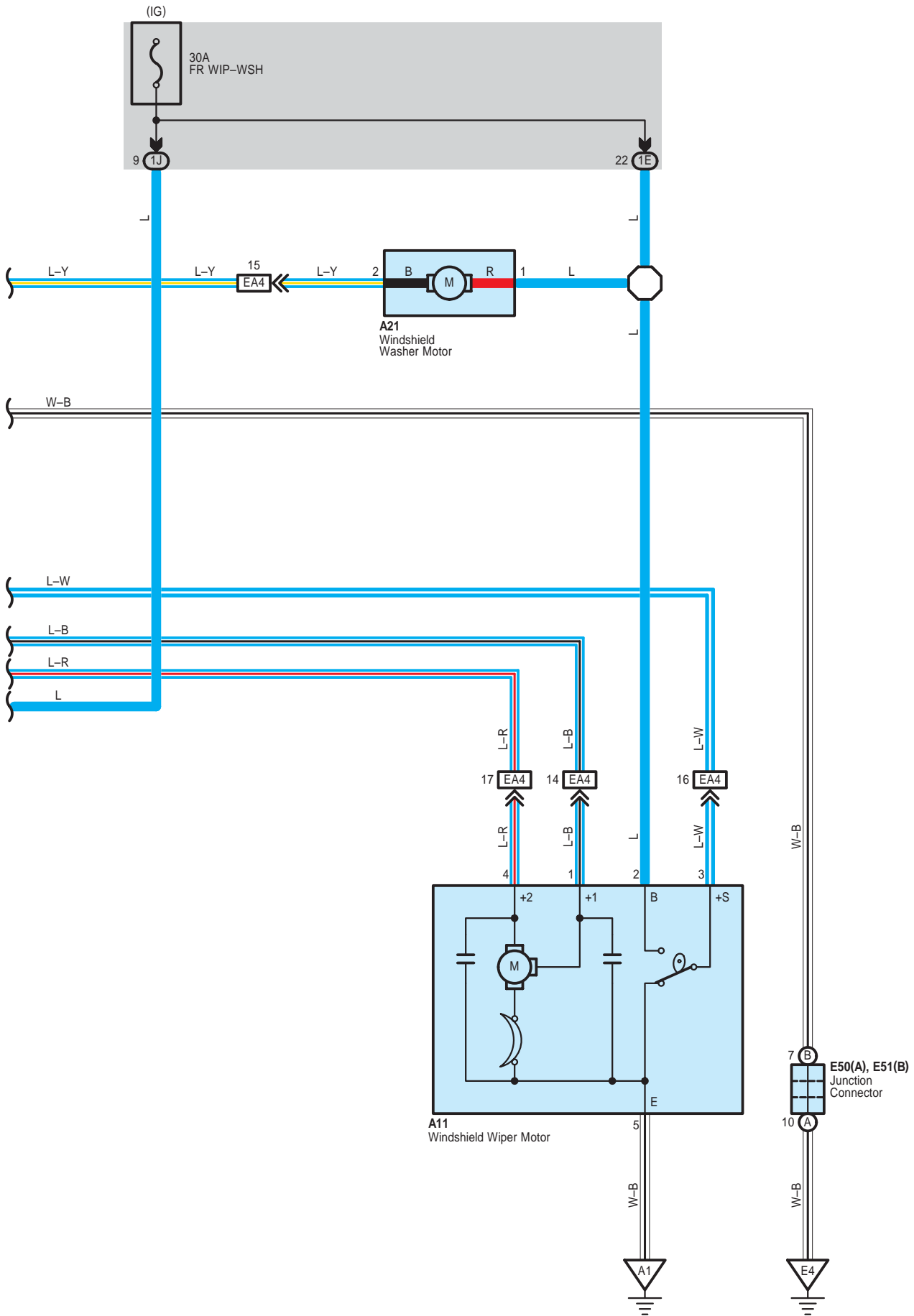

Front Wiper and Washer

 : **Parts Location**

Code	See Page	Code	See Page	Code	See Page
A11	38	E19	42	E51	B 44
A21	38	E50	A 44		

 : **Junction Block and Wire Harness Connector**

Code	See Page	Junction Block and Wire Harness (Connector Location)
1E	24	Engine Room Main Wire and Driver Side J/B (Lower Finish Panel)
1J	25	Instrument Panel Wire and Driver Side J/B (Lower Finish Panel)

 : **Connector Joining Wire Harness and Wire Harness**

Code	See Page	Joining Wire Harness and Wire Harness (Connector Location)
EA4	51	Instrument Panel Wire and Engine Room Main Wire (Left Kick Panel)

 : **Ground Points**

Code	See Page	Ground Points Location
A1	50	Left Fender Apron
E4	51	Left Kick Panel

Rear Wiper and Washer

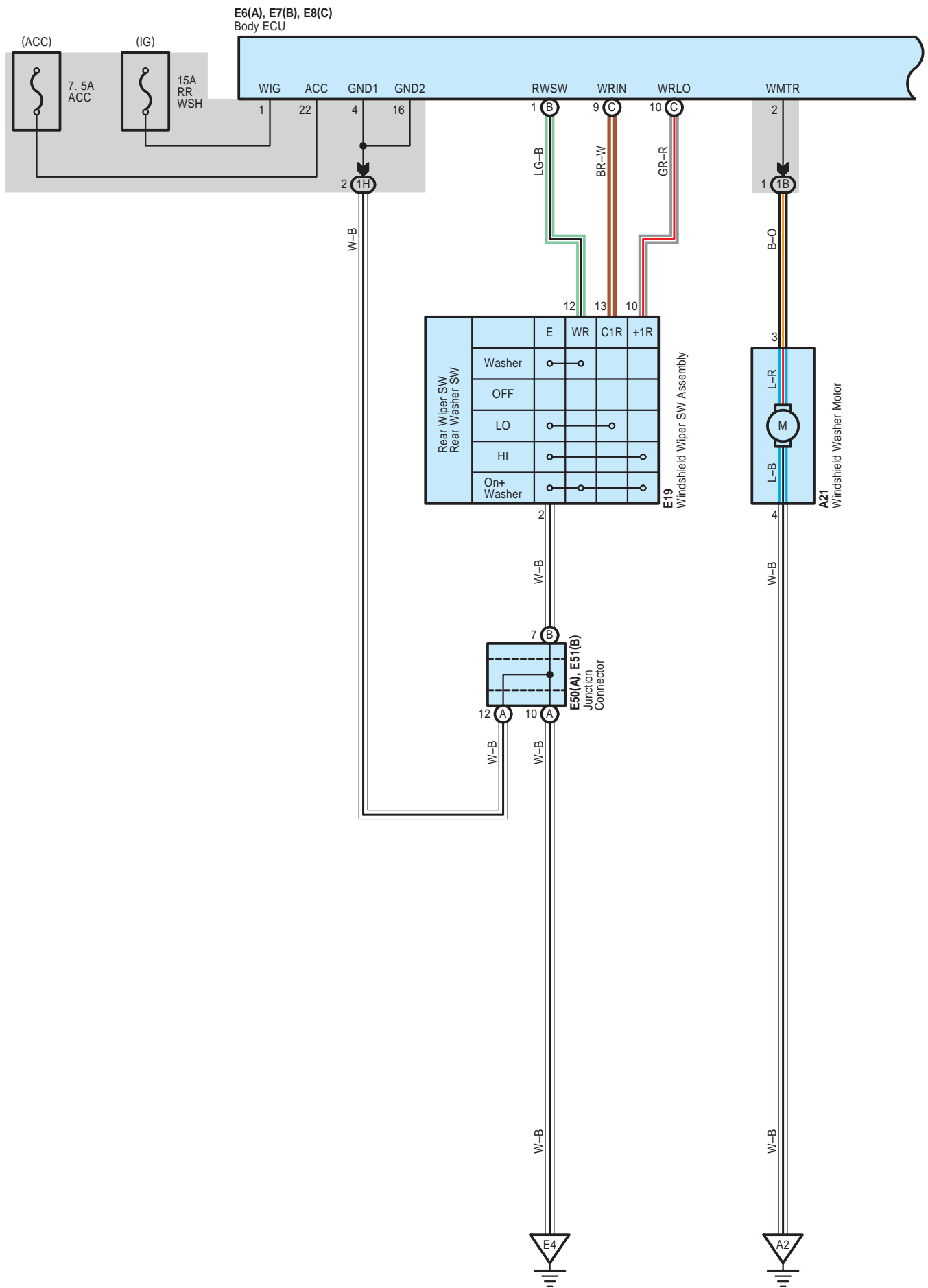

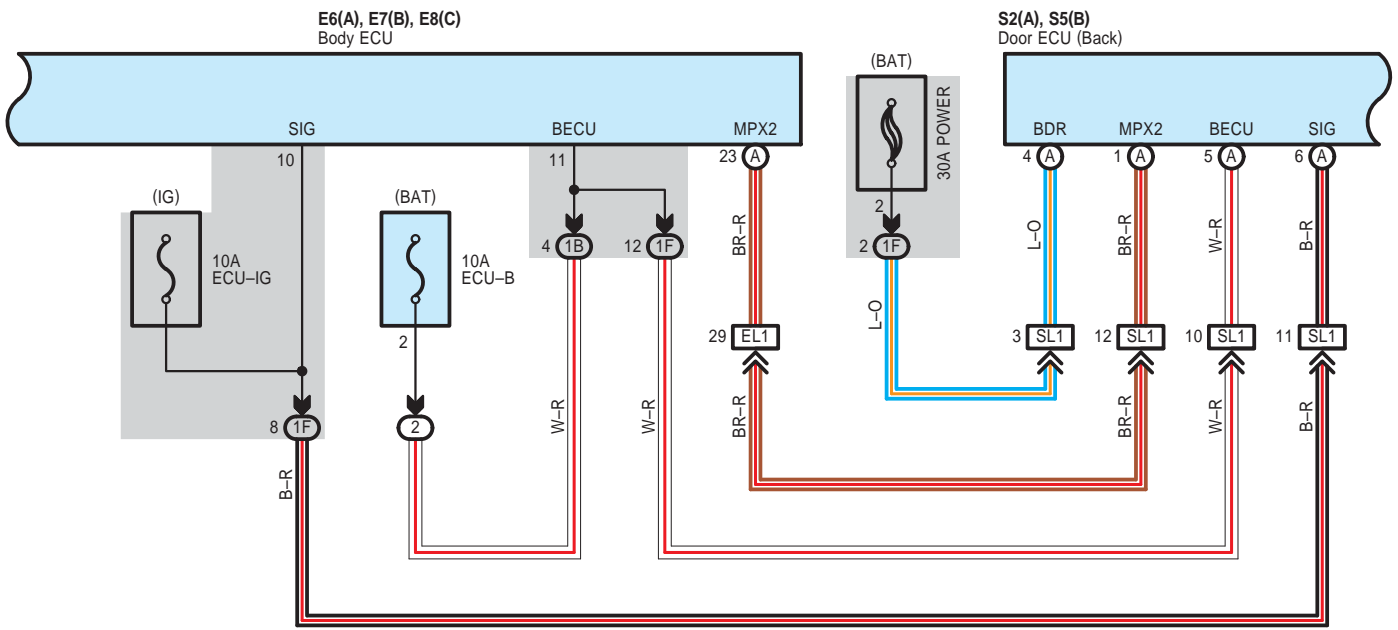

Rear Wiper and Washer

S2(A), S5(B)
Door ECU (Back)

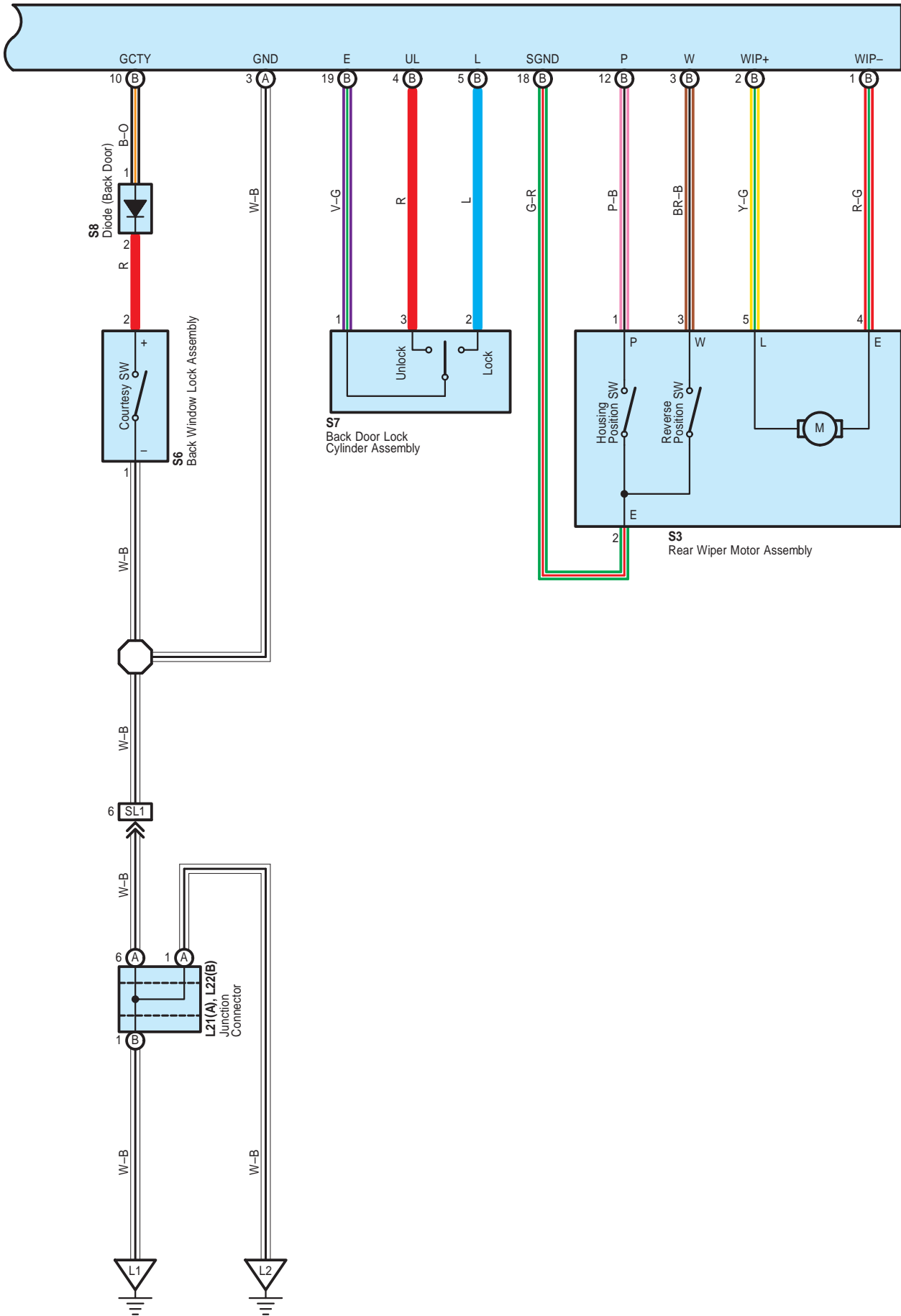

System Outline

Rear Wiper Operation Conditions

When all the following conditions are satisfied, the rear wiper operates if the rear wiper SW is at LO or HI position.

(1) Ignition SW ON

(2) When the back door glass hatch is closed.

* When the back door glass hatch is open, the rear wiper control is prohibited.

* If the back door glass hatch is opened during working of the rear wiper, the rear wiper is retracted forcibly. The rear wiper control resumes 3 seconds after the glass hatch is closed.

: Parts Location

Code	See Page	Code	See Page	Code	See Page			
A21	38	E50	A	44	S3	47		
E6	A	42	E51	B	44	S5	B	47
E7	B	42	L21	A	46	S6	47	
E8	C	42	L22	B	46	S7	47	
E19	42	S2	A	47	S8	47		

: Relay Blocks

Code	See Page	Relay Blocks (Relay Block Location)
2	22	Engine Room R/B No.2 (Engine Compartment Left)

: Junction Block and Wire Harness Connector

Code	See Page	Junction Block and Wire Harness (Connector Location)
1B	24	Engine Room Main Wire and Driver Side J/B (Lower Finish Panel)
1F	24	Floor No.2 Wire and Driver Side J/B (Lower Finish Panel)
1H	25	Instrument Panel Wire and Driver Side J/B (Lower Finish Panel)

: Connector Joining Wire Harness and Wire Harness

Code	See Page	Joining Wire Harness and Wire Harness (Connector Location)
EL1	51	Instrument Panel Wire and Floor No.2 Wire (Left Kick Panel)
SL1	52	Back Door No.1 Wire and Floor No.2 Wire (Left Quarter Panel)

: Ground Points

Code	See Page	Ground Points Location
A2	50	Right Fender Apron
E4	51	Left Kick Panel
L1	52	Floor Seat Crossmember LH
L2	52	Left Quarter Panel

Power Window

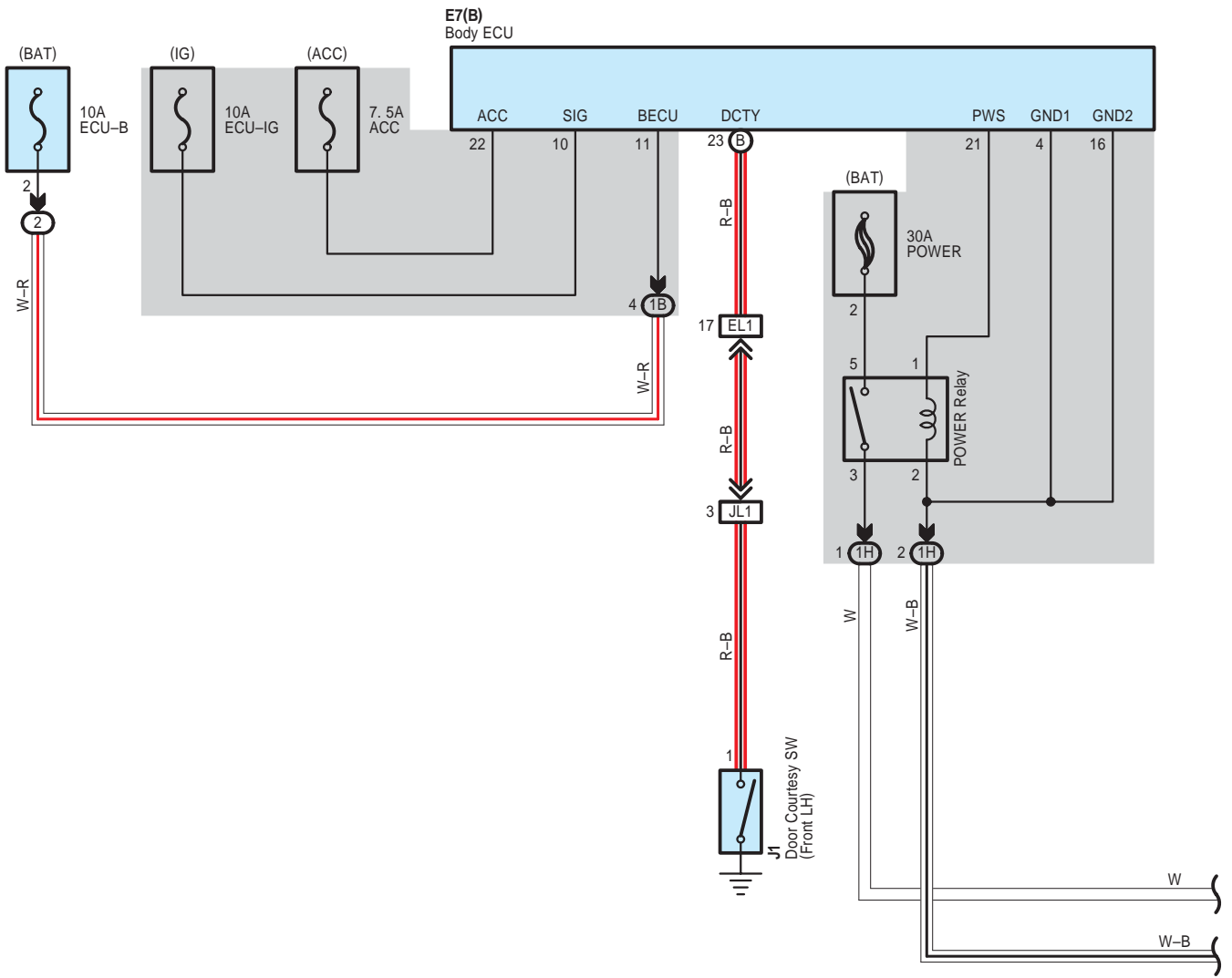

H5
Power Window Master SW

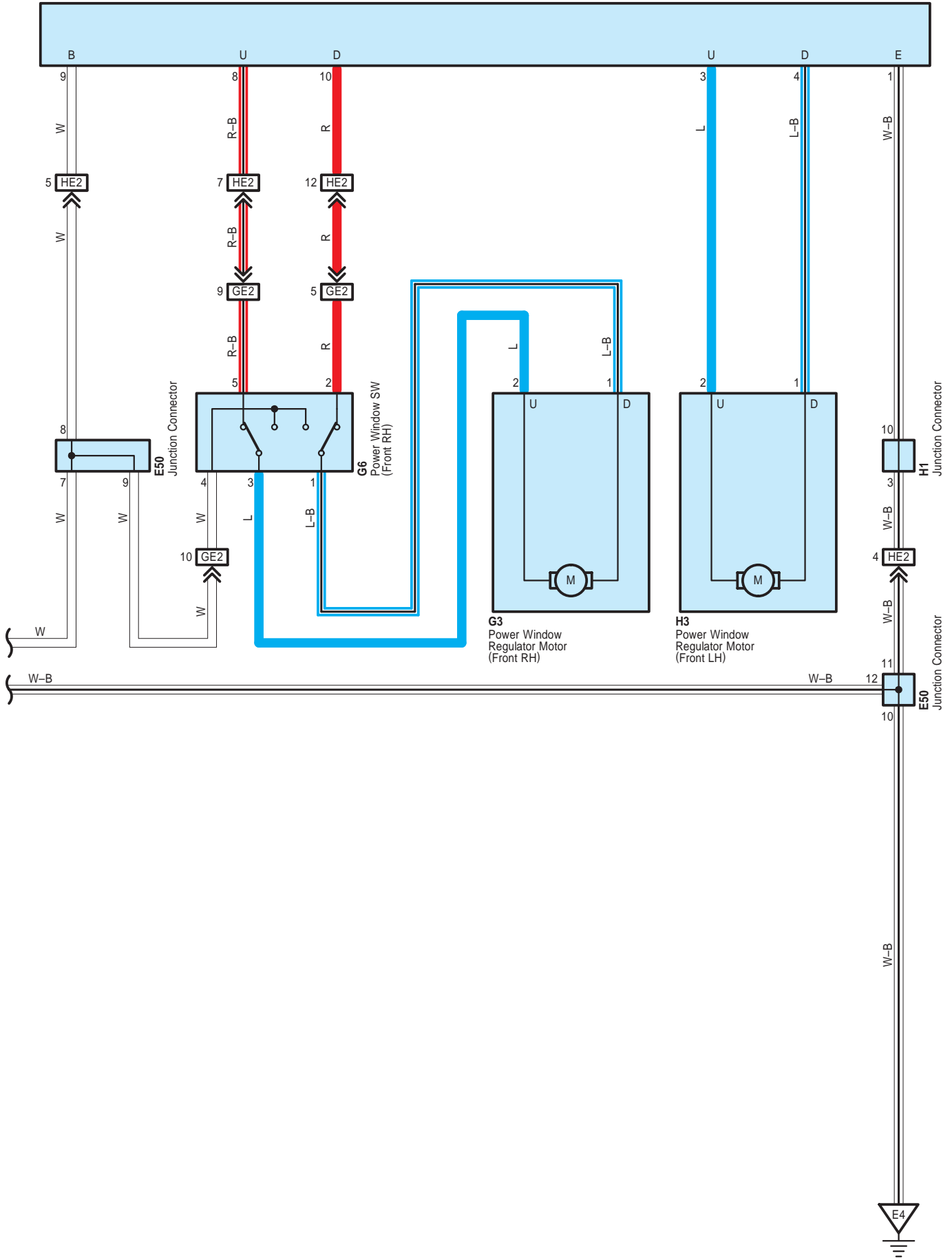

Power Window

: Parts Location

Code	See Page	Code	See Page	Code	See Page	
E7	B	42	G3	47	H3	47
E21	42	G6	47	H5	47	
E50	44	H1	47	J1	47	

: Relay Blocks

Code	See Page	Relay Blocks (Relay Block Location)
2	22	Engine Room R/B No.2 (Engine Compartment Left)

: Junction Block and Wire Harness Connector

Code	See Page	Junction Block and Wire Harness (Connector Location)
1B	24	Engine Room Main Wire and Driver Side J/B (Lower Finish Panel)
1H	25	Instrument Panel Wire and Driver Side J/B (Lower Finish Panel)
5D	28	Instrument Panel Wire and Center J/B LH (Instrument Panel LH)
5N		

: Connector Joining Wire Harness and Wire Harness

Code	See Page	Joining Wire Harness and Wire Harness (Connector Location)
EL1	51	Instrument Panel Wire and Floor No.2 Wire (Left Kick Panel)
GE2	51	Front Door RH Wire and Instrument Panel Wire (Right Kick Panel)
HE2	51	Front Door LH Wire and Instrument Panel Wire (Left Kick Panel)
JL1	52	Rear Door No.2 Wire and Floor No.2 Wire (Left Quarter Panel)

: Ground Points

Code	See Page	Ground Points Location
E4	51	Left Kick Panel

Door Lock Control

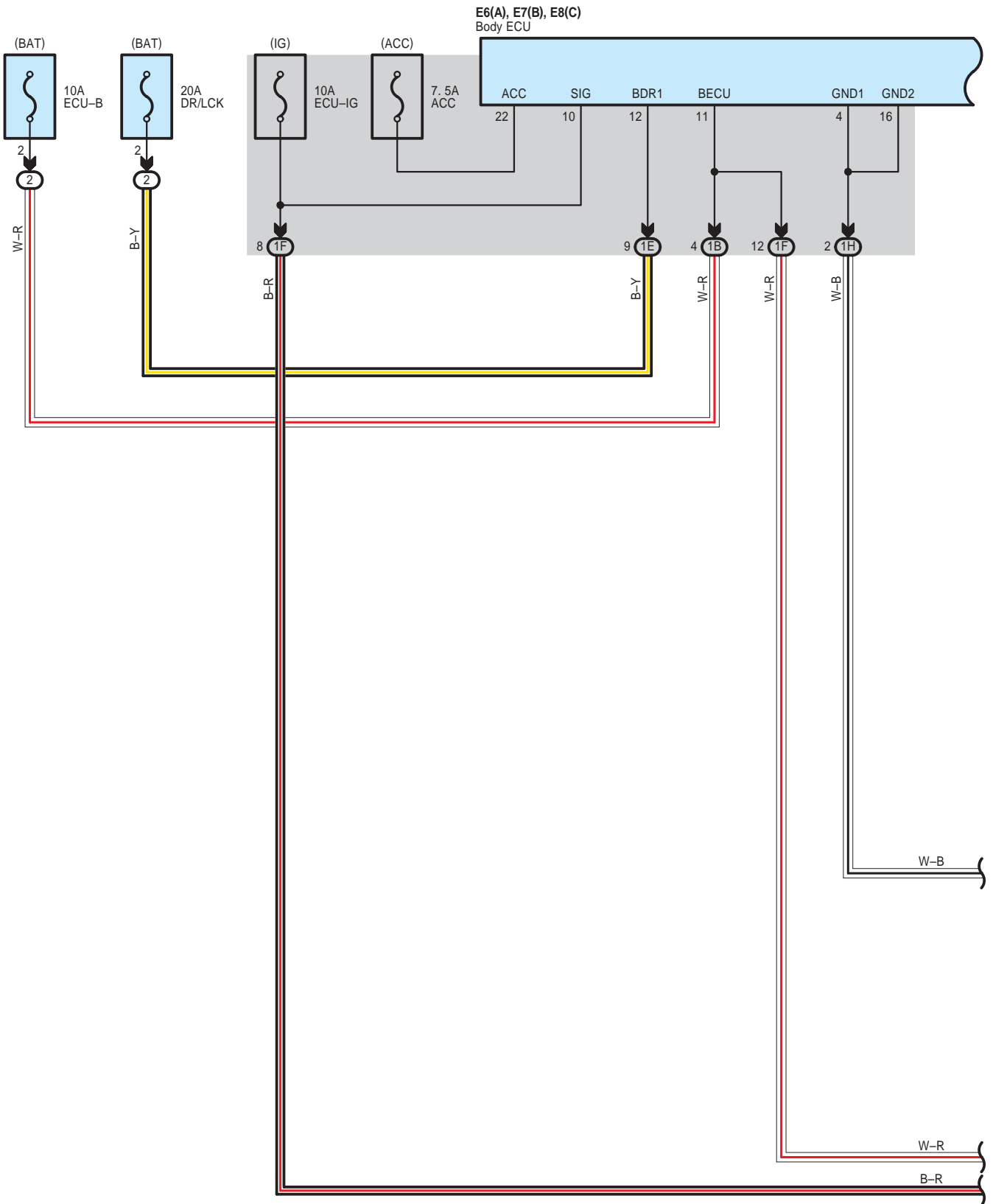

E6(A), E7(B), E8(C)
Body ECU

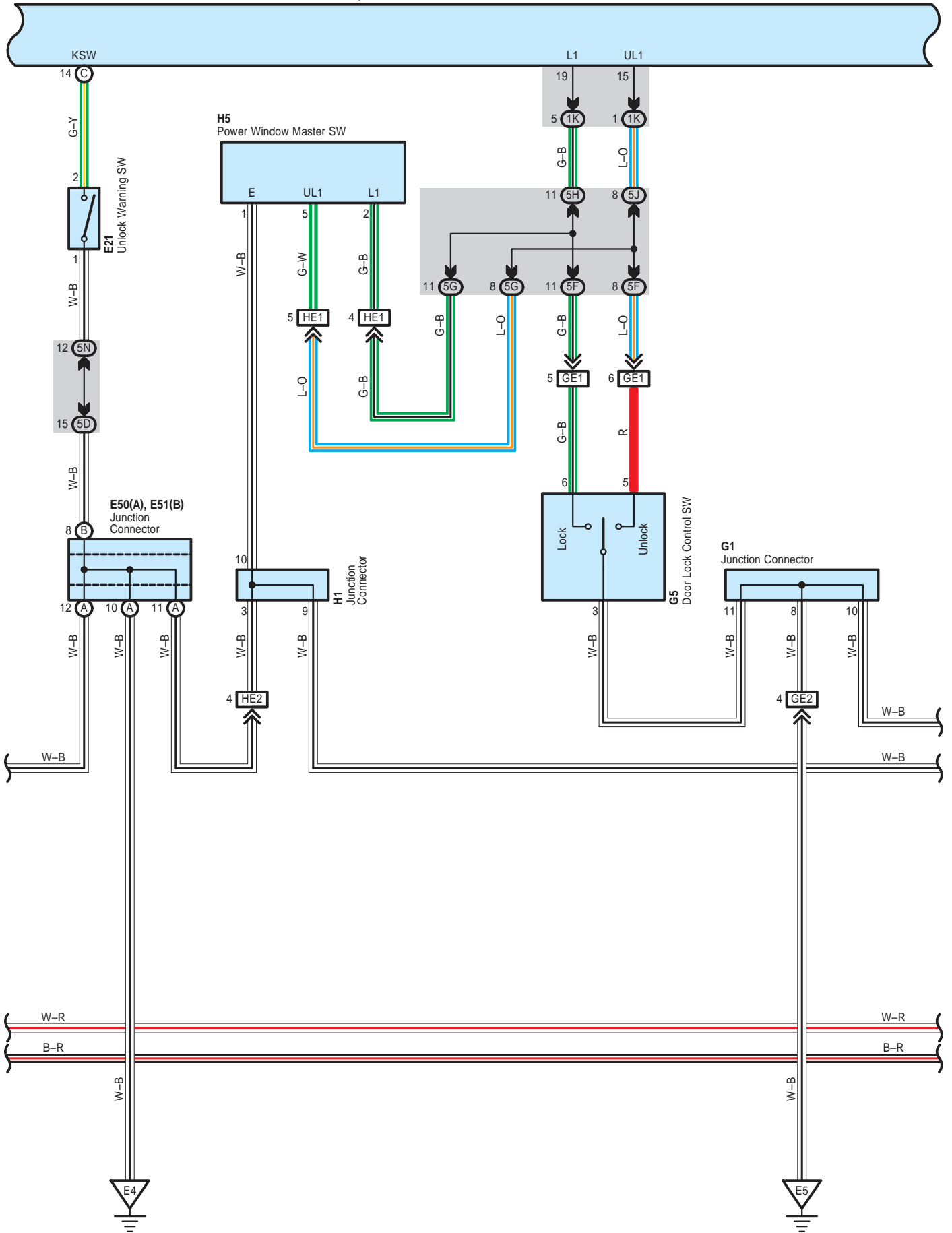

Door Lock Control

E6(A), E7(B), E8(C)
Body ECU

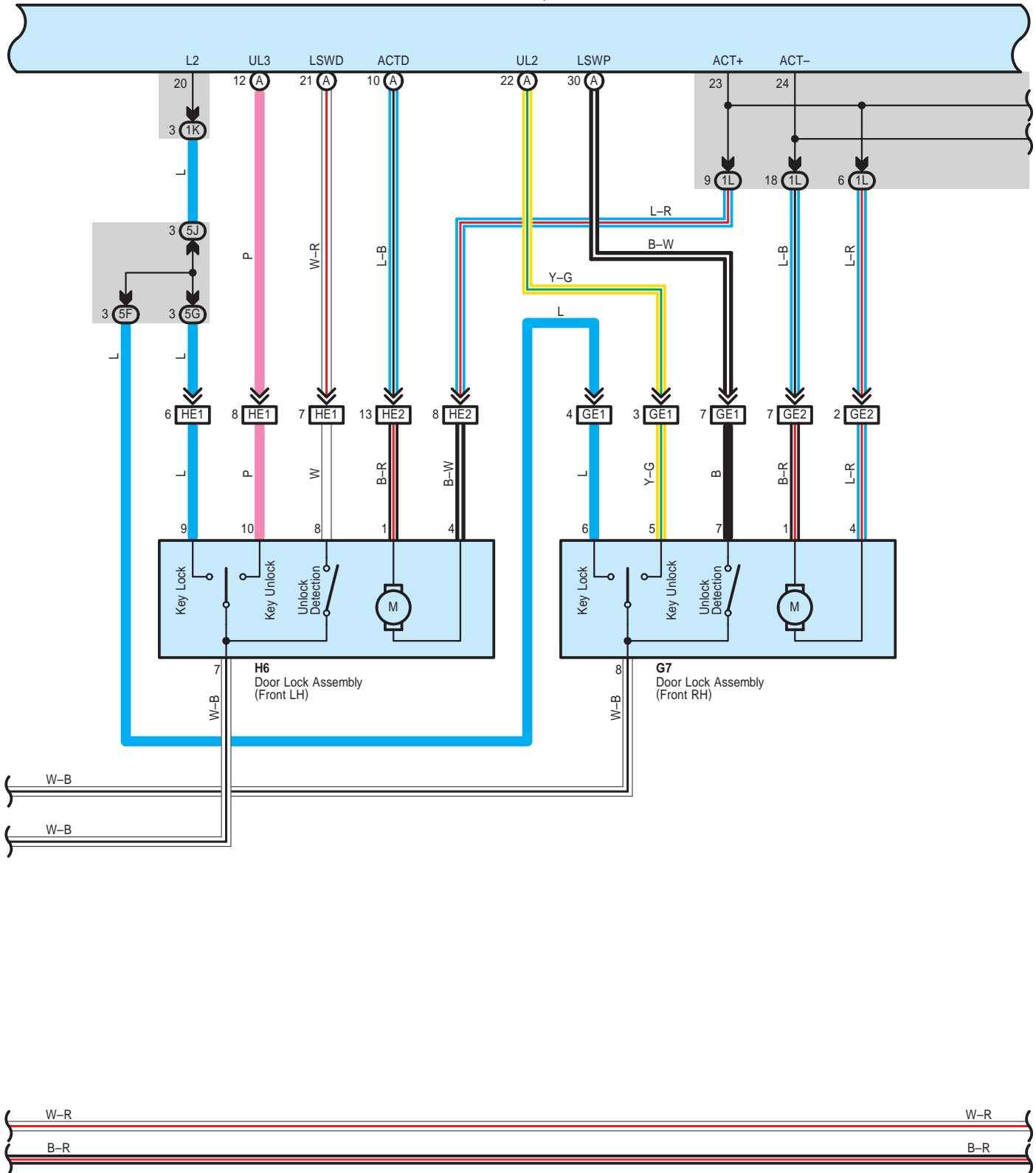

E6(A), E7(B), E8(C)
Body ECU

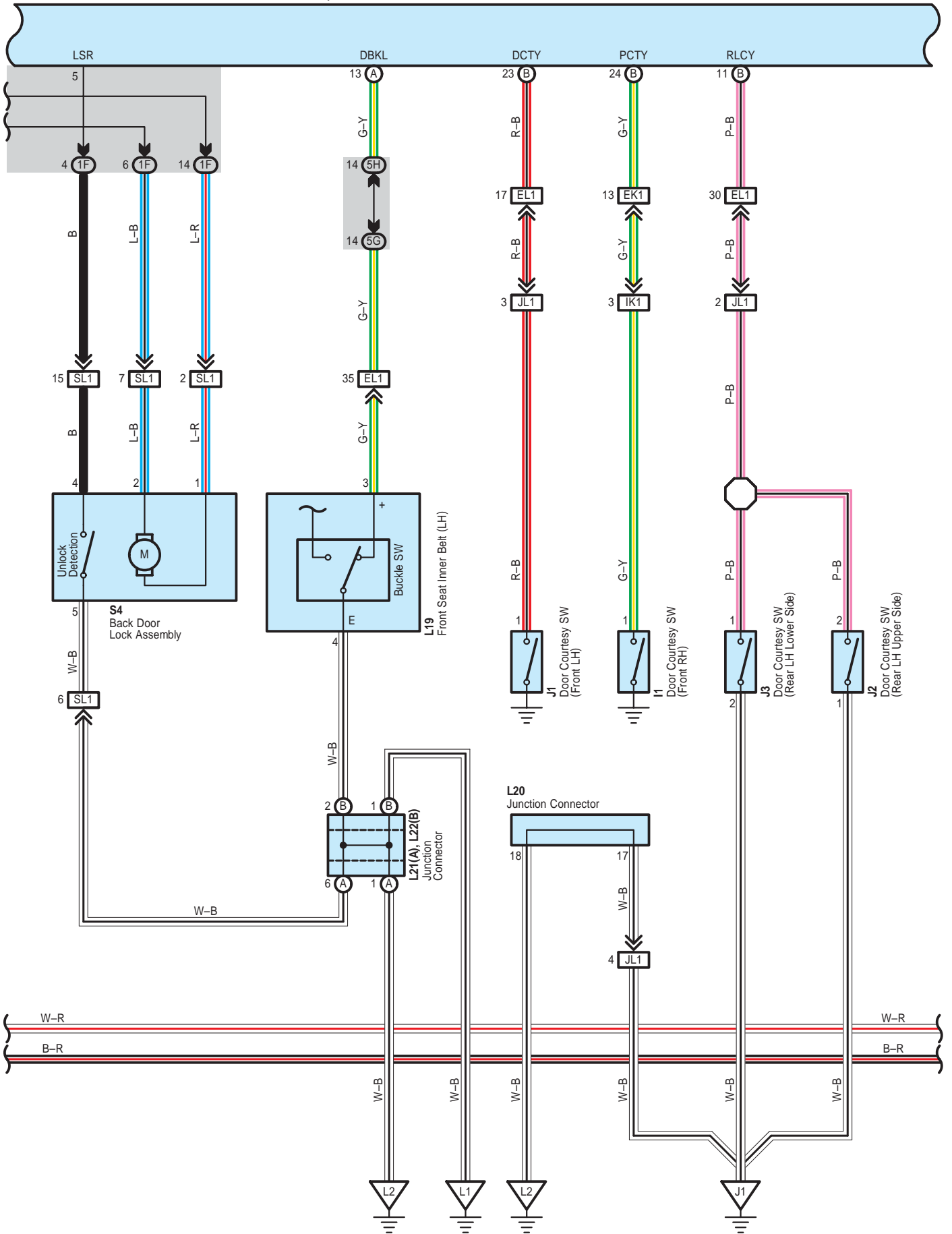

Door Lock Control

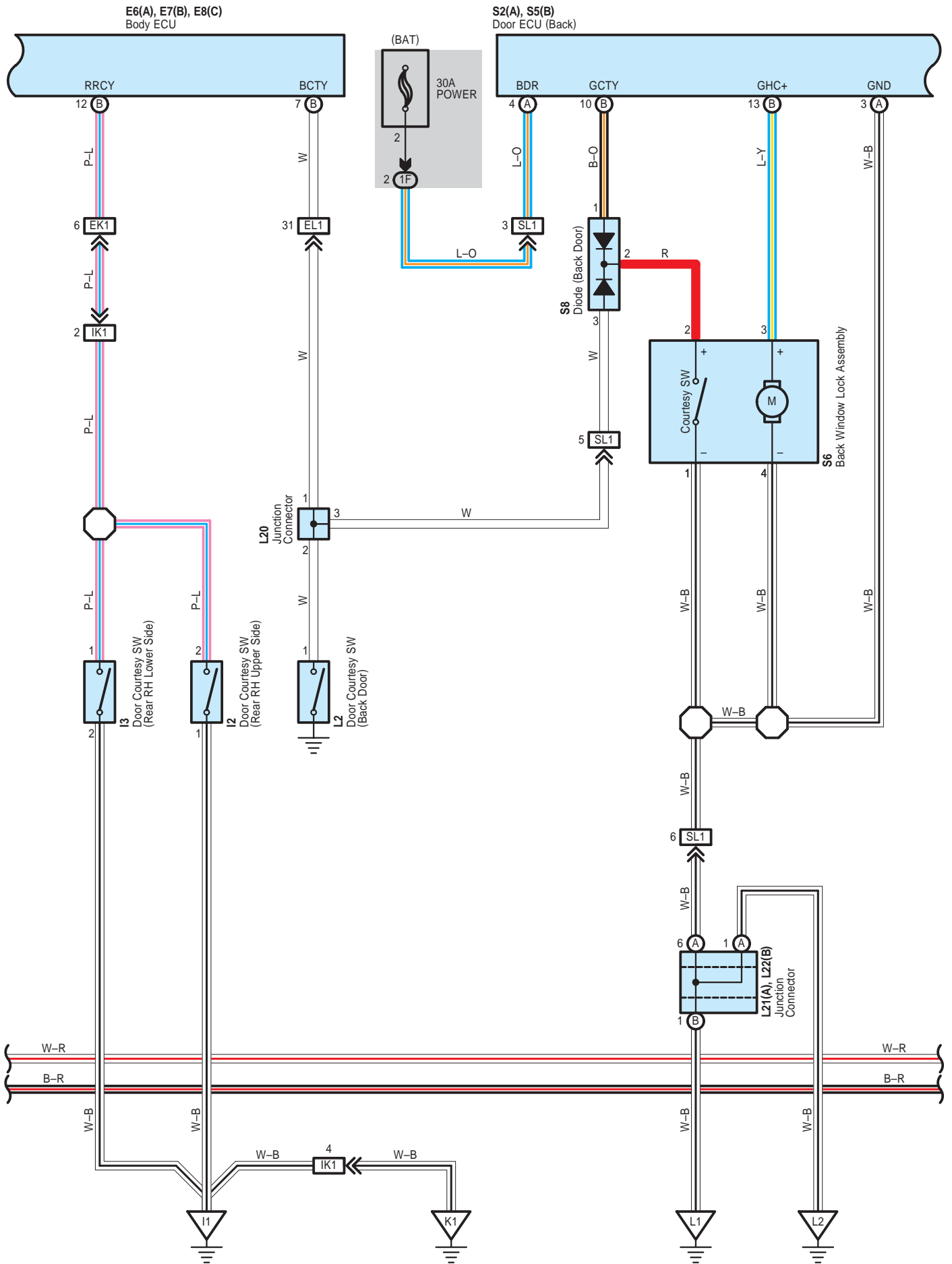

S2(A), S5(B)
Door ECU (Back)

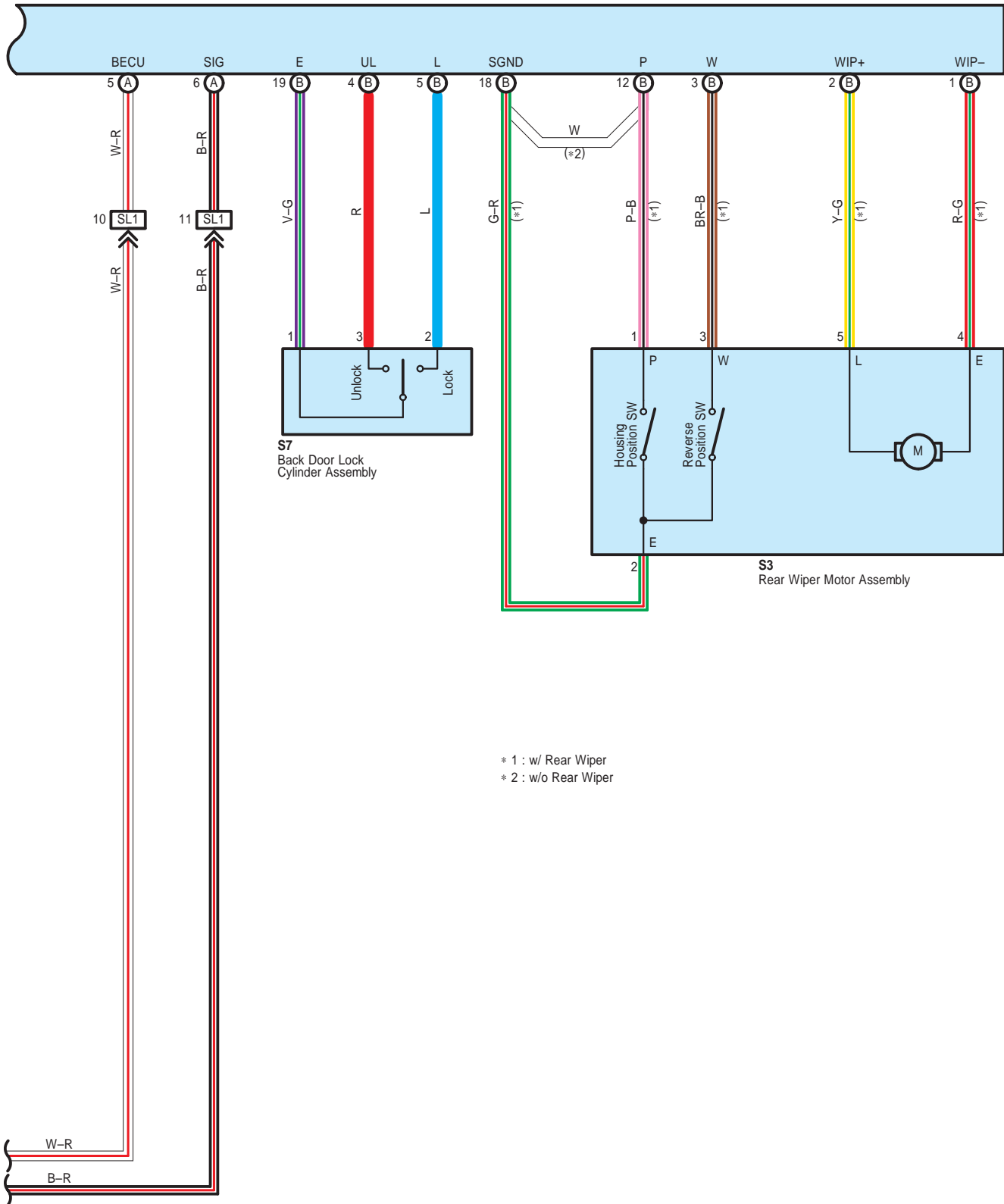

Door Lock Control

System Outline

The door lock control is controlled through the various signal input into the body ECU through communication control of the body ECU etc.

1. Manual Unlock Operation

When the door lock control SW of the driver's or passenger's side door is pushed to UNLOCK, the door will unlock.

2. Manual Lock Operation

When the door lock control SW of the driver's or passenger's side door is pushed to LOCK, the door will lock.

3. Door Key Unlock Operation

* Unlock operation from driver's side door

When the driver's side door is unlocked once using the ignition key, only the driver's side door is unlocked. If this operation is repeated within 3 seconds, all the other doors are unlocked.

* Unlock operation from passenger's side door

When the front passenger's side door is unlocked using the ignition key, all the other doors are unlocked, too.

4. Ignition Key Reminder Operation

When the door lock operation is made using the door knob with the ignition key remained inserted in the key cylinder and the door open, unlock operation is automatically made. Additionally, if lock operation is made with the door lock control SW or door key lock and unlock SW, unlock operation is automatically made after the lock operation has been completed.

5. Glass Hatch Opener Control

The glass hatch is opened when the back door key SW is kept on LOCK side for 0.8 second with the rear wiper in retracted condition.

○ : Parts Location

Code	See Page	Code	See Page	Code	See Page
E6	A 42	H5	47	L20	46
E7	B 42	H6	47	L21	A 46
E8	C 42	I1	47	L22	B 46
E21	42	I2	47	S2	A 47
E50	A 44	I3	47	S3	47
E51	B 44	J1	47	S4	47
G1	47	J2	47	S5	B 47
G5	47	J3	47	S6	47
G7	47	L2	46	S7	47
H1	47	L19	48	S8	47

○ : Relay Blocks

Code	See Page	Relay Blocks (Relay Block Location)
2	22	Engine Room R/B No.2 (Engine Compartment Left)

○ : Junction Block and Wire Harness Connector

Code	See Page	Junction Block and Wire Harness (Connector Location)
1B	24	Engine Room Main Wire and Driver Side J/B (Lower Finish Panel)
1E		
1F	24	Floor No.2 Wire and Driver Side J/B (Lower Finish Panel)
1H	25	Instrument Panel Wire and Driver Side J/B (Lower Finish Panel)
1K		
1L		
5D	28	Instrument Panel Wire and Center J/B LH (Instrument Panel LH)
5F		
5G		
5H		
5J		
5N		

 : Connector Joining Wire Harness and Wire Harness

Code	See Page	Joining Wire Harness and Wire Harness (Connector Location)
EK1	51	Instrument Panel Wire and Floor Wire (Right Kick Panel)
EL1	51	Instrument Panel Wire and Floor No.2 Wire (Left Kick Panel)
GE1	51	Front Door RH Wire and Instrument Panel Wire (Right Kick Panel)
GE2		
HE1	51	Front Door LH Wire and Instrument Panel Wire (Left Kick Panel)
HE2		
IK1	52	Rear Door No.1 Wire and Floor Wire (Right Quarter Panel)
JL1	52	Rear Door No.2 Wire and Floor No.2 Wire (Left Quarter Panel)
SL1	52	Back Door No.1 Wire and Floor No.2 Wire (Left Quarter Panel)

 : Ground Points

Code	See Page	Ground Points Location
E4	51	Left Kick Panel
E5	51	Right Kick Panel
I1	52	Access Door RH
J1	52	Access Door LH
K1	52	Floor Seat Crossmember RH
L1	52	Floor Seat Crossmember LH
L2	52	Left Quarter Panel

Wireless Door Lock Control

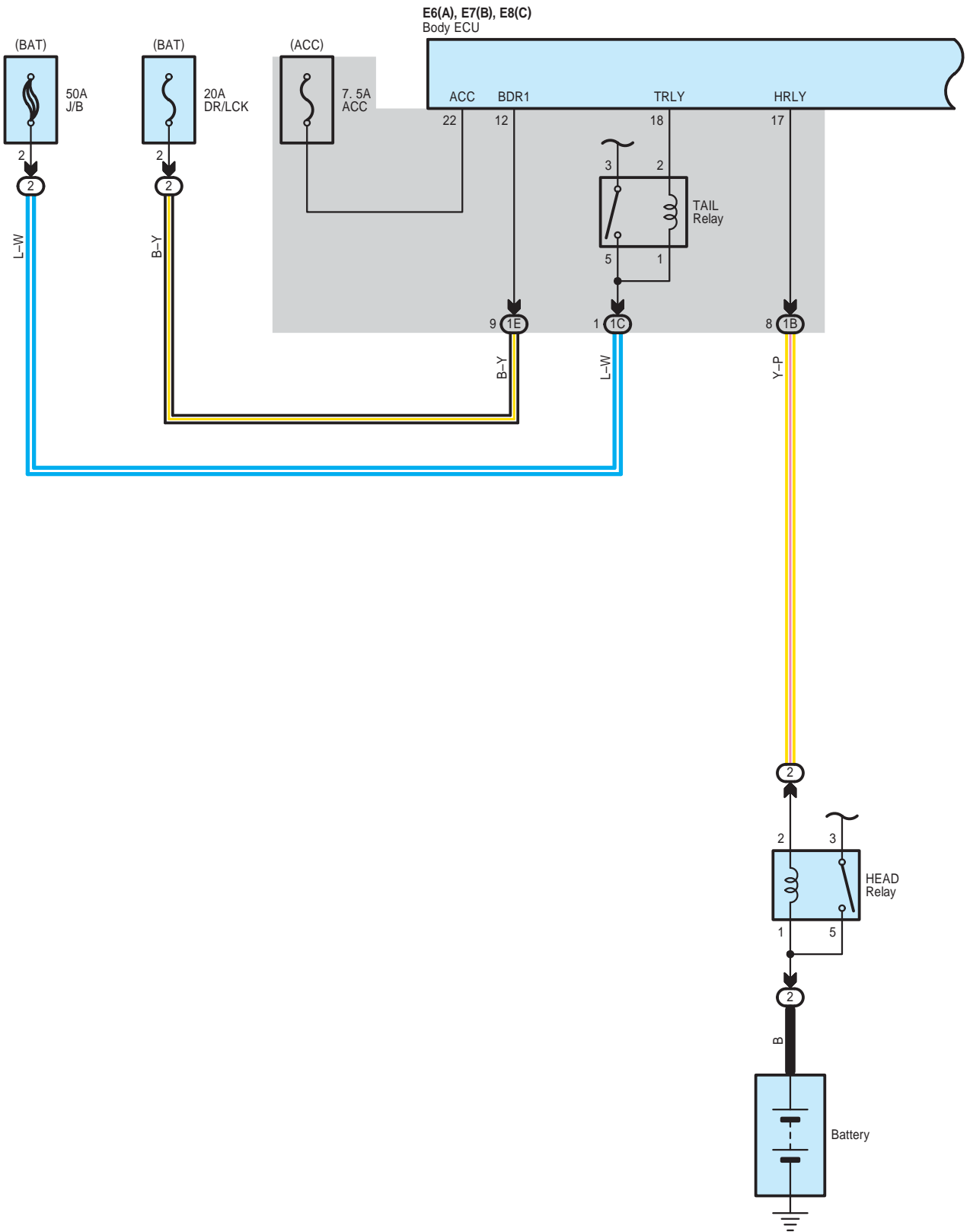

E6(A), E7(B), E8(C)
Body ECU

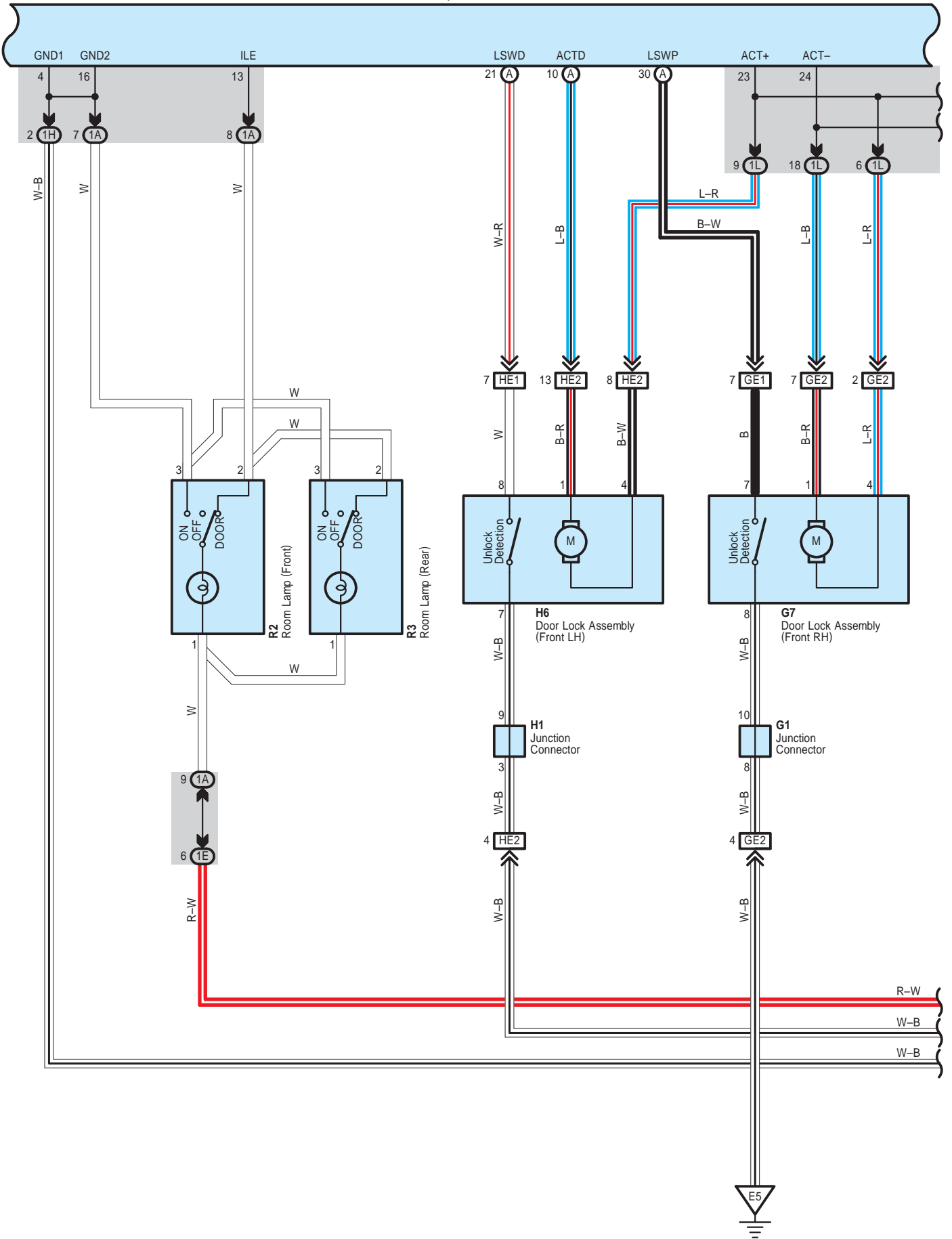

Wireless Door Lock Control

E6(A), E7(B), E8(C)
Body ECU

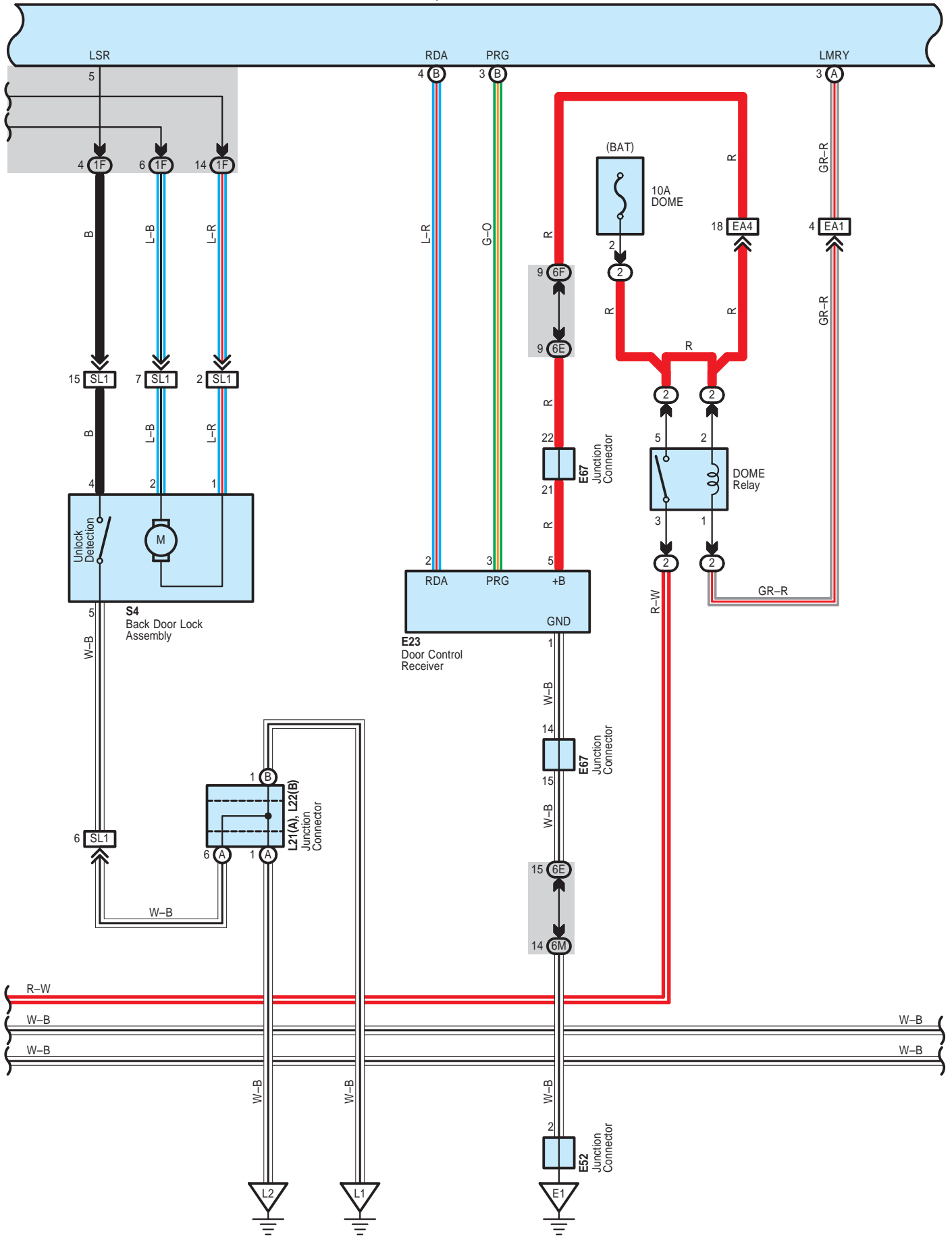

E6(A), E7(B), E8(C)
Body ECU

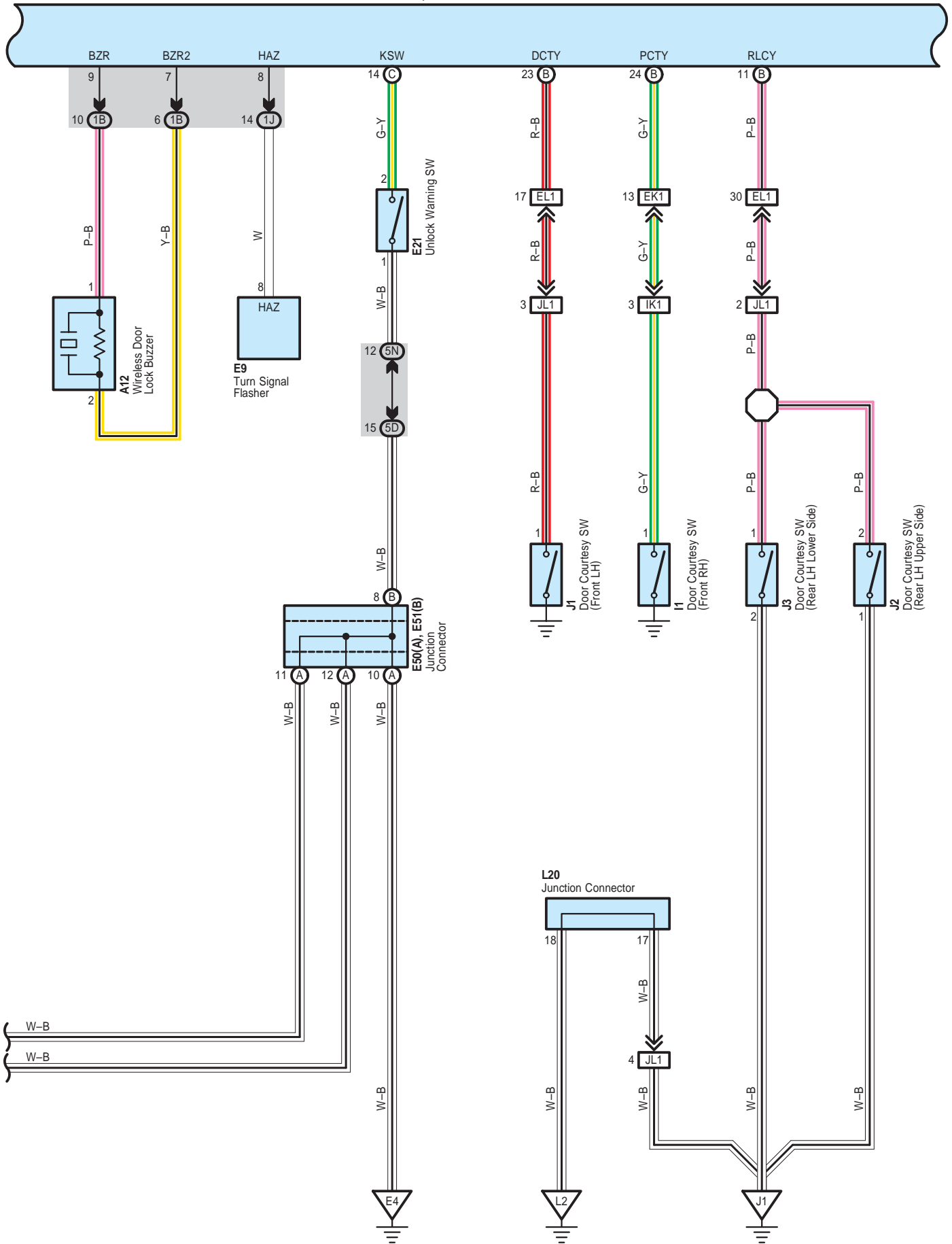

Wireless Door Lock Control

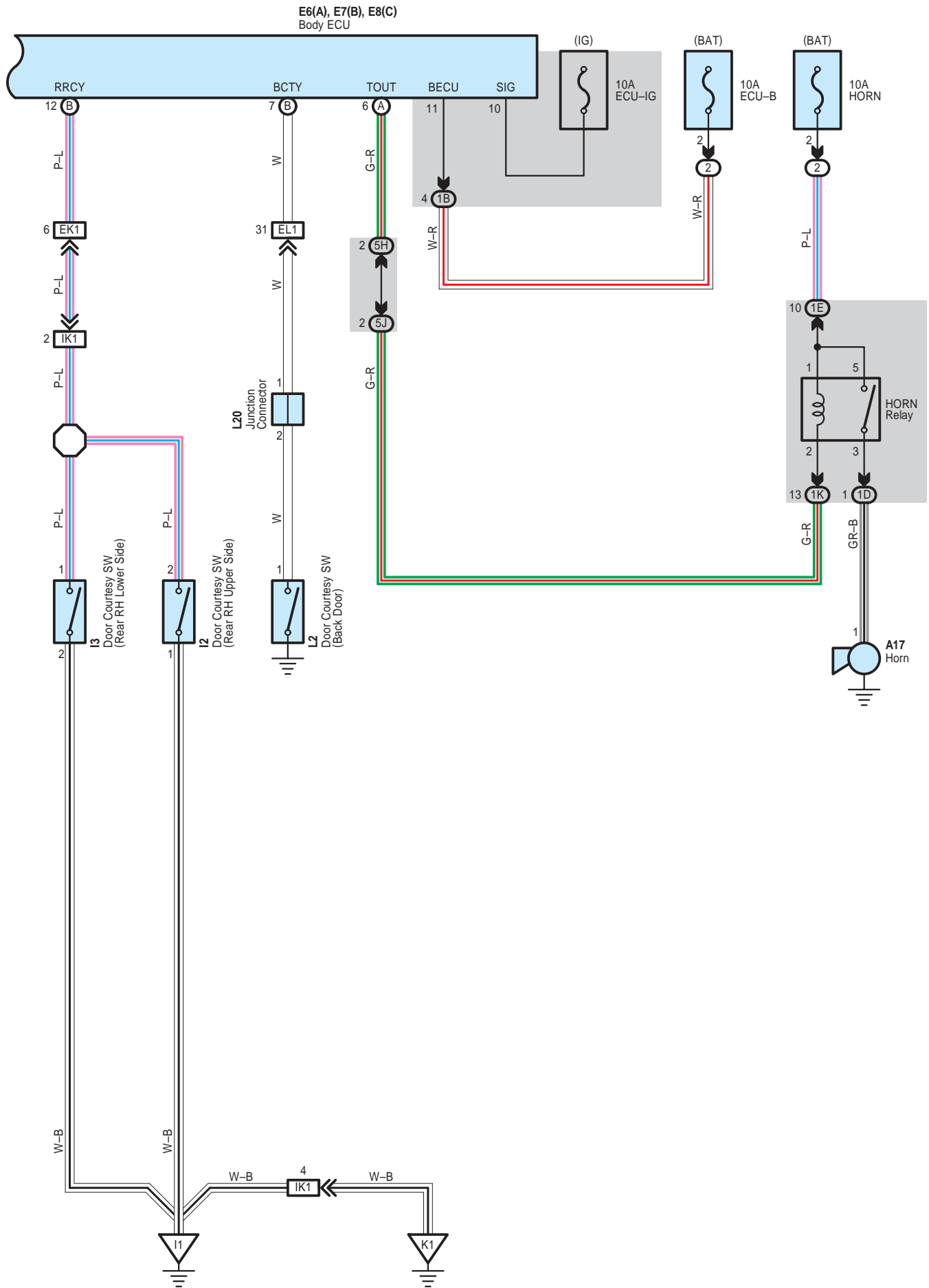

System Outline

Door lock control (Lock and unlock) and panic control is performed by remote control, without the ignition key inserted in the door key cylinder, using low-power electrical waves emitted by a transmitter.

1. Normal Operation

* Lock operation

When the lock SW on the transmitter is pressed, all the doors are locked.

* Unlock operation

When the unlock SW on the transmitter is pressed once, only the driver door is unlocked. When the unlock SW is pressed again within 3 seconds, all the doors are unlocked.

2. Auto Lock Function

When the door is not actually opened within 60 seconds after the door has been unlocked by the unlock SW on the transmitter, all the doors are automatically locked. If any of the following conditions are detected, the wireless door lock does not function.

* Any door is opened.

* The ignition key is inserted into the ignition SW.

* When the lock detection SW of all the doors are locked.

3. Wireless Door Lock Stop Function

If any of the following conditions are detected, the wireless door lock does not function.

Lock operation

* When any door is open (Door courtesy SW on)

* The ignition key is inserted into the ignition SW (Unlock warning SW on)

* Ignition SW is on

Unlock operation

* Ignition SW is on

4. Buzzer Sound Function

During lock operation, when the body ECU receives a lock signal from the door lock detection SW, the wireless door lock buzzer goes on once. During unlock operation, when the body ECU receives an unlock signal from the door lock detection SW, the wireless door lock buzzer goes on twice.

With any door open, when the body ECU receives a lock signal from the transmitter, the wireless door lock buzzer goes on for approx. 10 seconds. If the door is closed, or ignition SW is on, or if the unlock signal is received from the transmitter while the buzzer is on, the buzzer stops.

5. Visual Confirmation of Lock or Unlock

During lock operation, when the body ECU receives a lock signal from the door lock detection SW, the turn signal light is flashed once. During unlock operation, when the body ECU receives an unlock signal from the door lock detection SW, the turn signal light is flashed twice.

6. Remote Panic Operation

Panic will function when doors are locked or unlocked, open or closed. When the panic button (Transmitter) is pushed once, interior lights light up, and horn sounds and turn signal light, headlights and taillight flash. Then, the panic or the unlock button (Transmitter) is pushed once more, interior lights are turned off, sounding and flashing will stop. Panic will not function when ignition key is in ignition key cylinder.

7. Repeat Function

If the lock detection signal in response to the output signal is not received after the body ECU has output the lock signal, the lock signal is output again.

8. Illuminated Entry Function

When the body ECU detects the unlock state after the unlock operation has been made, it turns on the lights, such as the interior light for approx. 15 sec. If all the doors are locked during this operation, lighting is cancelled and the lights immediately fade out.

Wireless Door Lock Control

: Parts Location

Code		See Page	Code	See Page	Code	See Page
A12		38	E52	44	J2	47
A17		38	E67	44	J3	47
E6	A	42	G1	47	L2	46
E7	B	42	G7	47	L20	46
E8	C	42	H1	47	L21	A
E9		42	H6	47	L22	B
E21		42	I1	47	R2	47
E23		42	I2	47	R3	47
E50	A	44	I3	47	S4	47
E51	B	44	J1	47		

: Relay Blocks

Code	See Page	Relay Blocks (Relay Block Location)
2	22	Engine Room R/B No.2 (Engine Compartment Left)

: Junction Block and Wire Harness Connector

Code	See Page	Junction Block and Wire Harness (Connector Location)
1A	24	Roof Wire and Driver Side J/B (Lower Finish Panel)
1B	24	Engine Room Main Wire and Driver Side J/B (Lower Finish Panel)
1C		
1D		
1E		
1F		
1H	25	Instrument Panel Wire and Driver Side J/B (Lower Finish Panel)
1J		
1K		
1L		
5D	28	Instrument Panel Wire and Center J/B LH (Instrument Panel LH)
5H		
5J		
5N		
6E	32	Instrument Panel Wire and Center J/B RH (Instrument Panel RH)
6F		
6M		

: Connector Joining Wire Harness and Wire Harness

Code	See Page	Joining Wire Harness and Wire Harness (Connector Location)
EA1	51	Instrument Panel Wire and Engine Room Main Wire (Left Kick Panel)
EA4		
EK1	51	Instrument Panel Wire and Floor Wire (Right Kick Panel)
EL1	51	Instrument Panel Wire and Floor No.2 Wire (Left Kick Panel)
GE1	51	Front Door RH Wire and Instrument Panel Wire (Right Kick Panel)
GE2		
HE1	51	Front Door LH Wire and Instrument Panel Wire (Left Kick Panel)
HE2		
IK1	52	Rear Door No.1 Wire and Floor Wire (Right Quarter Panel)
JL1	52	Rear Door No.2 Wire and Floor No.2 Wire (Left Quarter Panel)
SL1	52	Back Door No.1 Wire and Floor No.2 Wire (Left Quarter Panel)



: Ground Points

Code	See Page	Ground Points Location
E1	51	Instrument Panel Brace RH
E4	51	Left Kick Panel
E5	51	Right Kick Panel
I1	52	Access Door RH
J1	52	Access Door LH
K1	52	Floor Seat Crossmember RH
L1	52	Floor Seat Crossmember LH
L2	52	Left Quarter Panel

ECT and A/T Indicator

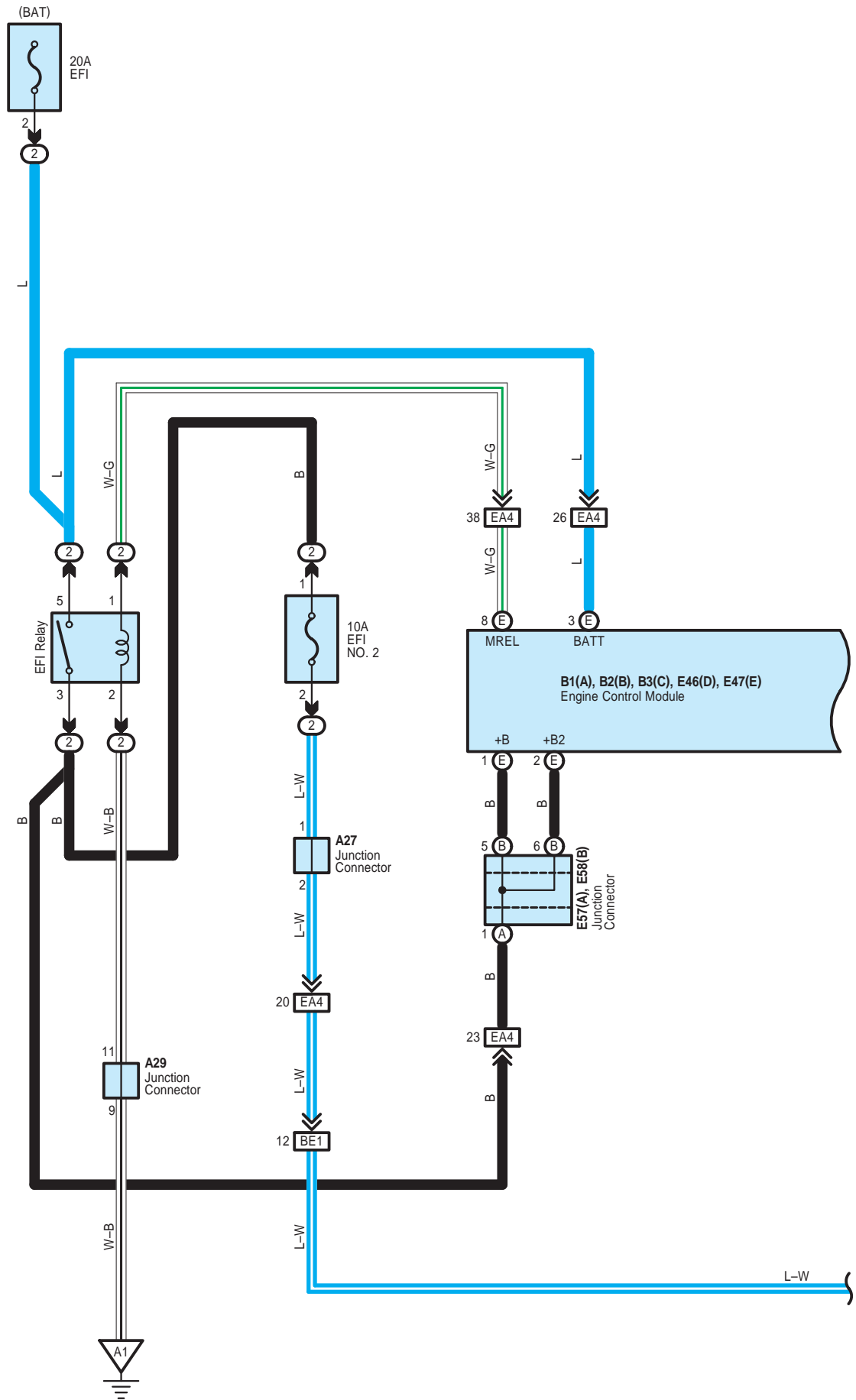

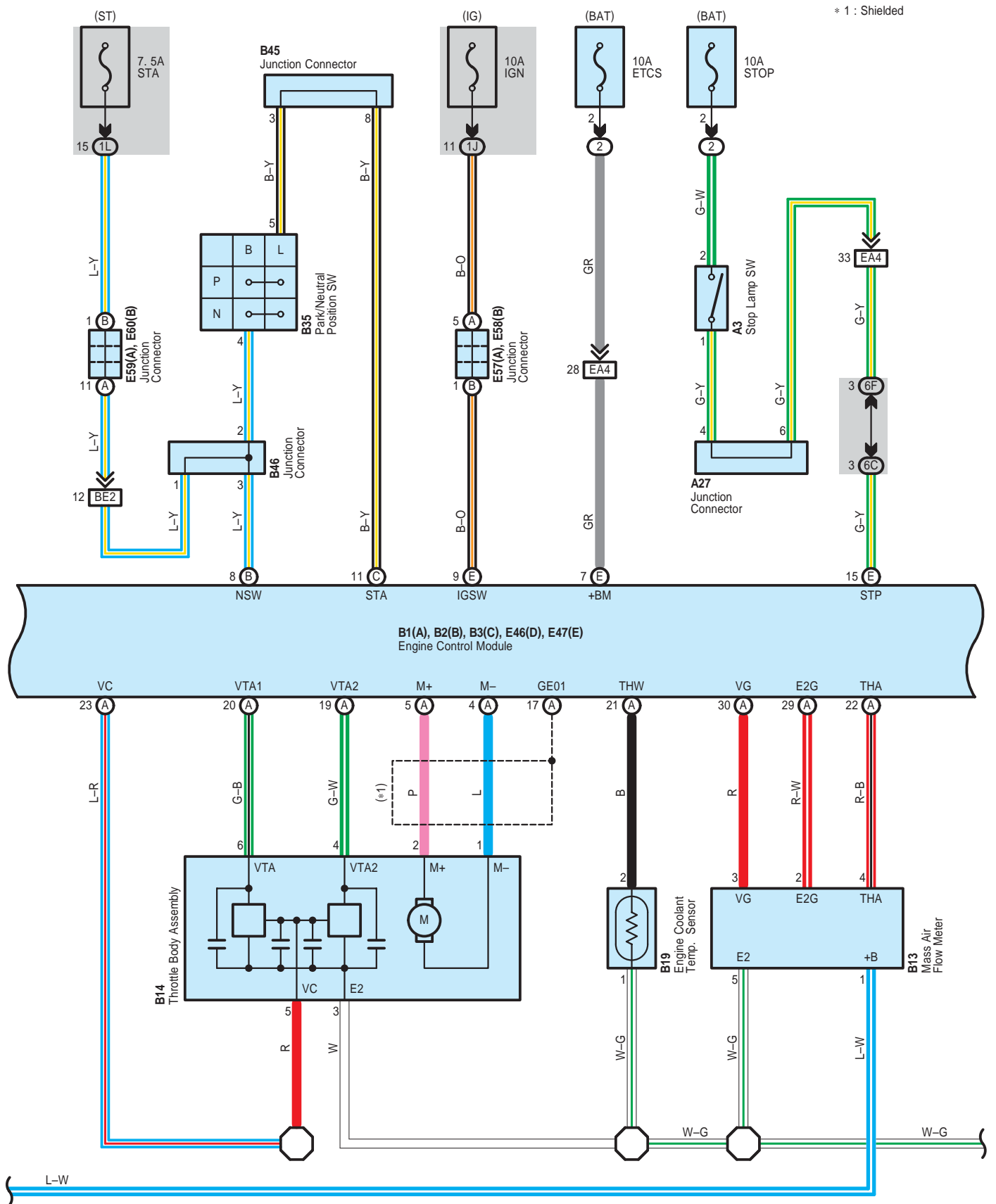

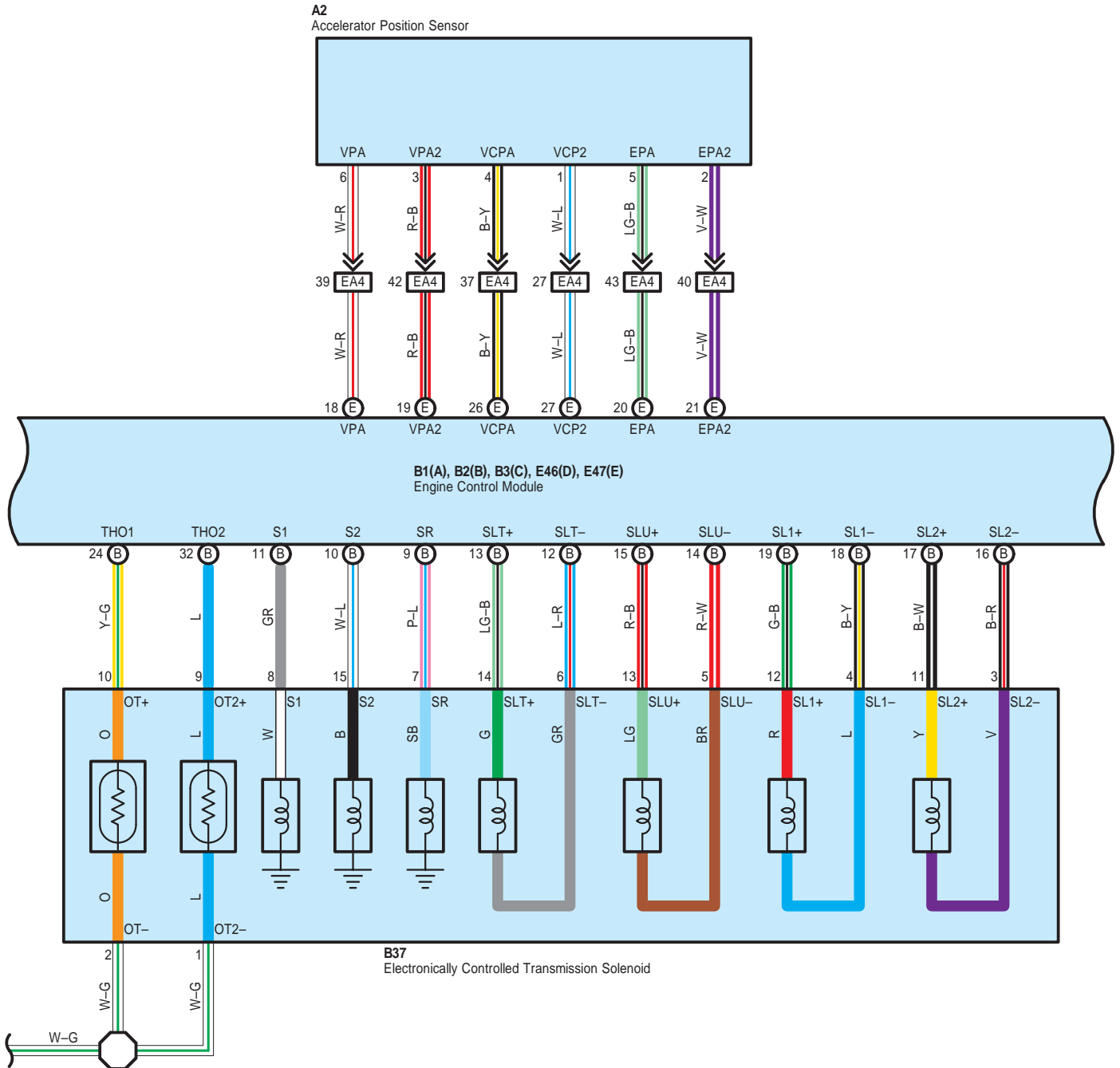

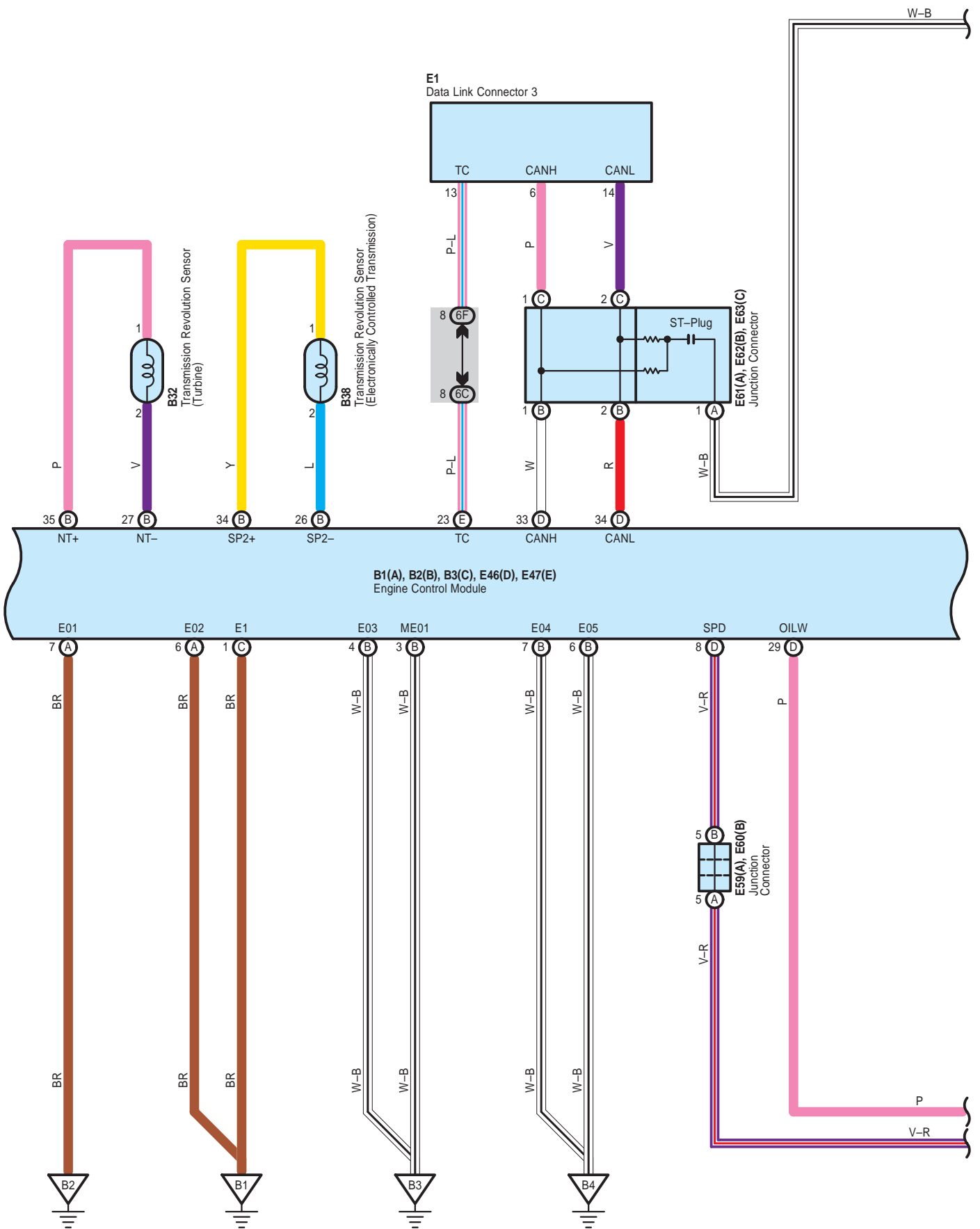

ECT and A/T Indicator

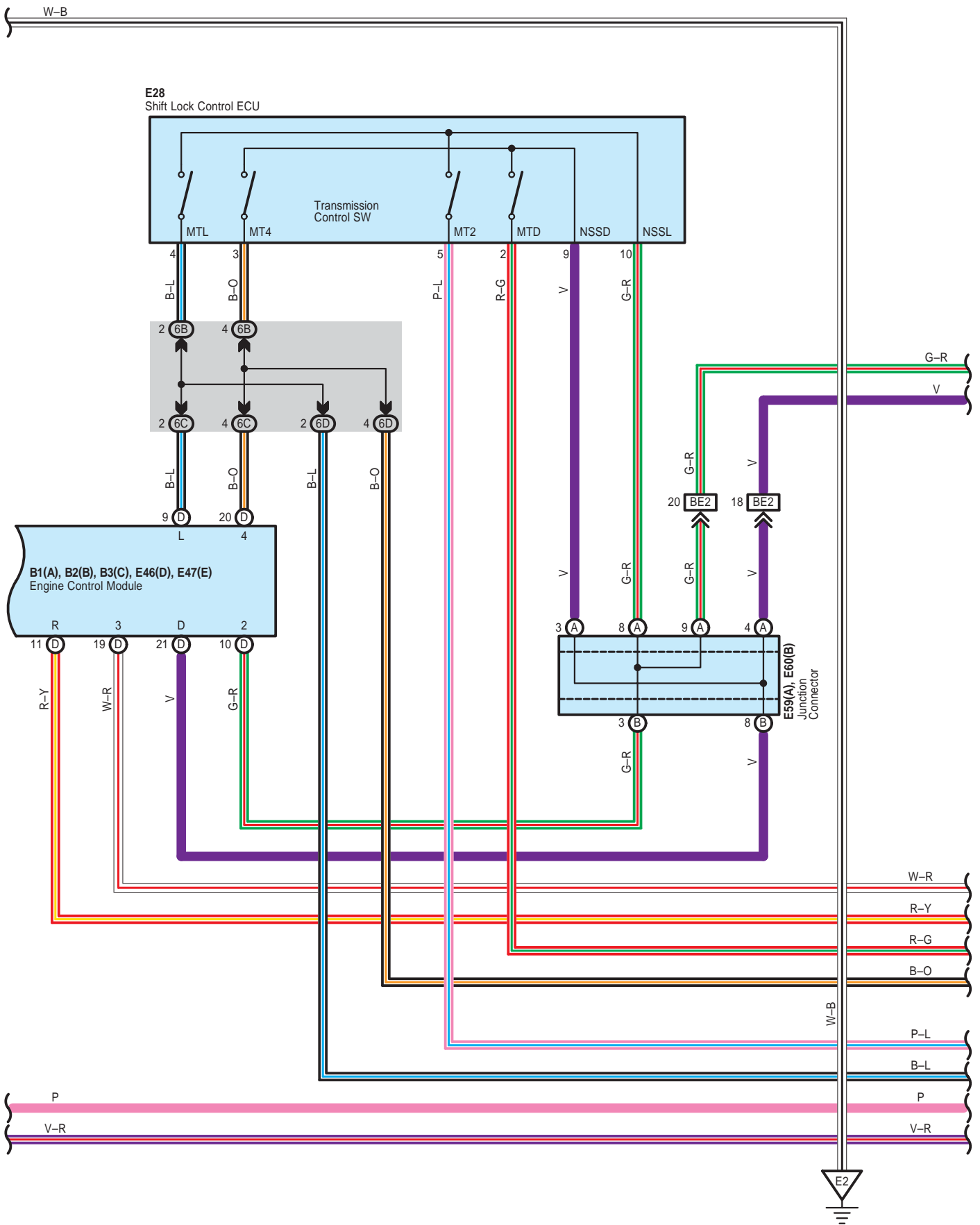

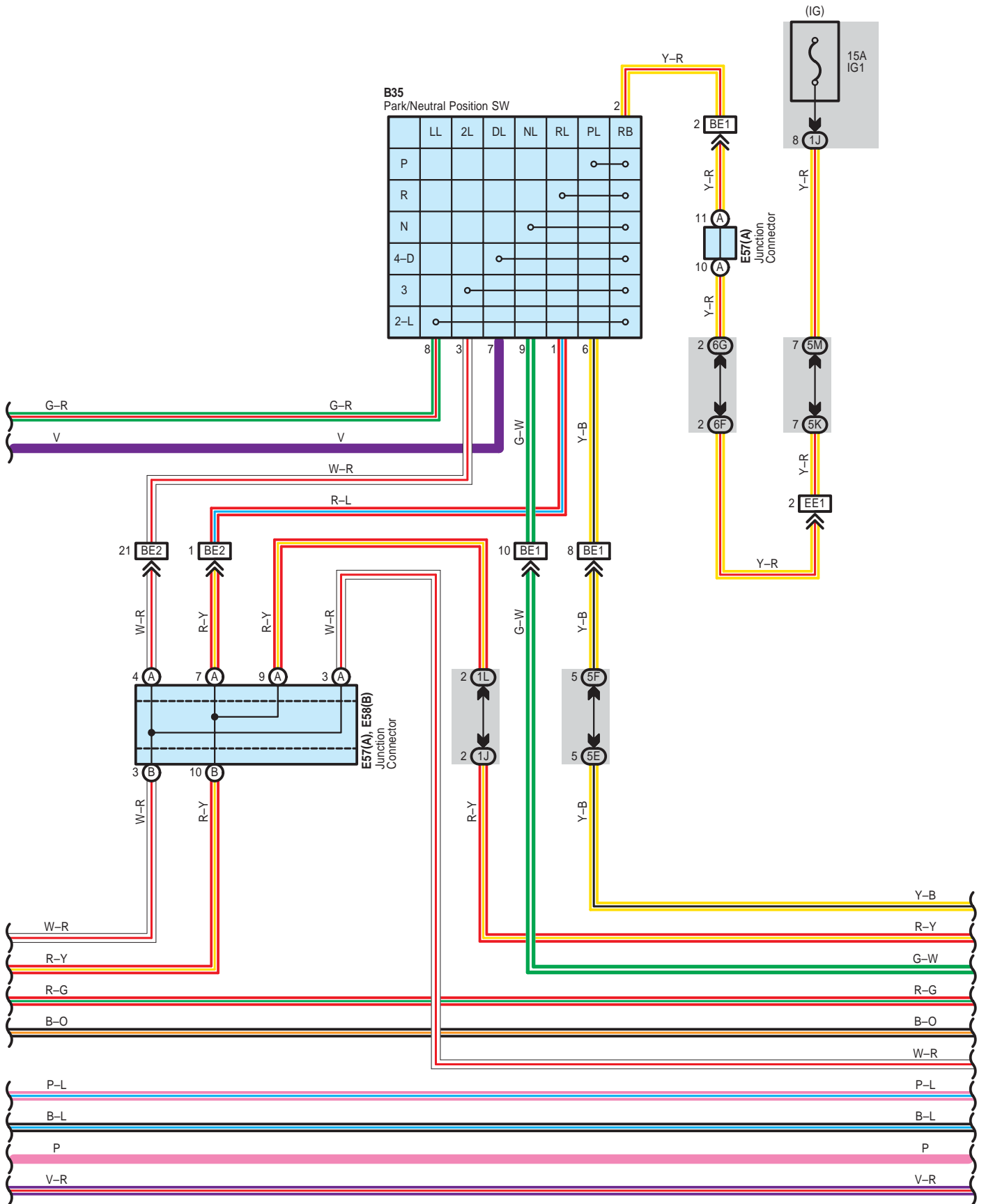

ECT and A/T Indicator

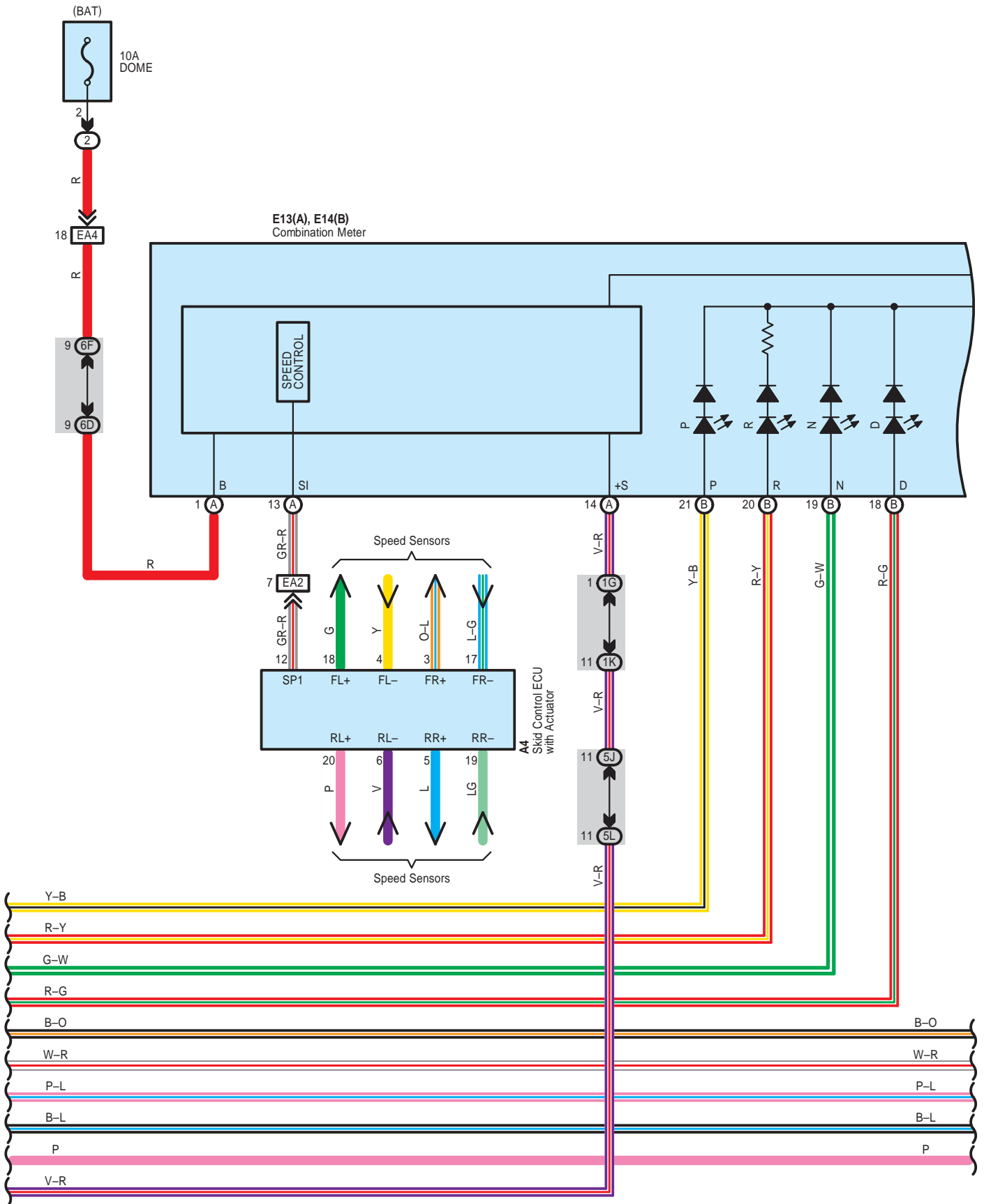

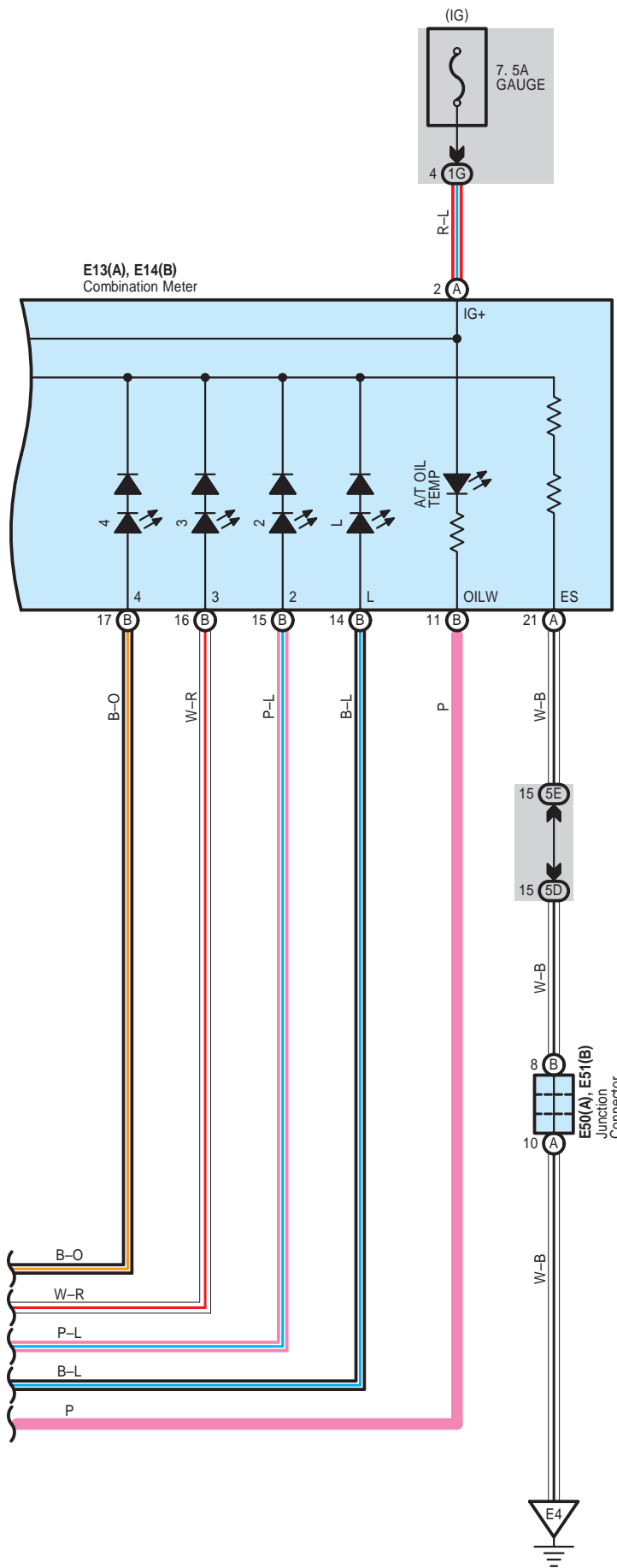

ECT and A/T Indicator

System Outline

Previous automatic transmissions have selected each gear shift using mechanically controlled throttle hydraulic pressure, governor hydraulic pressure and lock-up hydraulic pressure. The electronically controlled transmission, however, electrically controls the line pressure, throttle pressure, lock-up pressure and accumulator pressure etc. through the solenoid valve. The electronically controlled transmission is a system which precisely controls gear shift timing and lock-up timing in response to the vehicle's driving conditions and the engine condition detected by various sensors. It makes smooth driving possible by shift selection for each gear which is the most appropriate to the driving conditions at that time, and by preventing downing, squat and gear shift shock when starting off.

1. Gear Shift Operation

When driving, the engine warm up condition is input as a signal to TERMINAL THW of the engine control module from the engine coolant temp. sensor and the vehicle speed signal from vehicle speed sensor is input to TERMINAL SP2+ of the engine control module. At the same time, the throttle valve opening signal from the throttle position sensor is input to TERMINALS VTA1 and VTA2 of the engine control module as throttle angle signal.

Based on these signals, the engine control module selects the best shift position for the driving conditions and sends current to the electronically controlled transmission solenoid.

2. Line Hydraulic Pressure Control

The engine control module adjusts the line hydraulic pressure to the optimal level by controlling TERMINAL SLT+ of the module according to the engine torque data. This realizes the smooth gear shifting.

3. High Response Gear Shifting Control

The engine control module performs the high response engine torque up control to control the ignition-timing lag as well as opening the electronic throttle when shifting down. By doing this, the gear shifting is performed in a short period of time. Moreover, the engine control module uses the orifice switching control, which optimizes the speed of applying and reducing the hydraulic pressure. And it realizes the fine shifting condition by applying and reducing hydraulic pressure slowly when the gear shifting shock is important and quickly when the high response is required.

4. Clutch Hydraulic Pressure Control

The engine control module controls the clutch operation in the optimal timing and with the best hydraulic pressure according to the engine torque data and the number of the clutch revolution

5. Lock-Up and Flexible Lock-Up Control

The engine control module carries out the lock-up control by controlling the TERMINAL SLU+ of the module according to the shift position, vehicle speed, throttle opening degree and running conditions. The engine control module also steadily keeps applying the lock-up clutch a delicate slippage to improve the transmission efficiency (Fuel efficiency) of the torque converter.

6. Stop Lamp SW Circuit

If the brake pedal is depressed (Stop lamp SW on) when driving in lock-up condition, a signal is input to TERMINAL STP of the engine control module. The engine control module operates and cuts the current to the solenoid to release lock-up.

7. AI-Shift Control

The engine control module judges whether the road is downslope or upslope by detecting the throttle opening degree or the vehicle's speed. Moreover it can expect the winding roads by detecting the turning condition of the vehicle. The engine control module keeps unnecessary shifting up from the fourth gear from operating and carries out the automatic shifting down to the third gear in order to control the vehicle running according to the road conditions. The engine control module also reads the driver's intention during driving from his (her) accelerating operation and the running conditions of the vehicle. As a result of that, ideal shifting patters for each driver are automatically selected without any switching operations.

○ : Parts Location

Code	See Page	Code	See Page	Code	See Page
A2	45	B32	40	E47	E 43
A3	45	B35	40	E50	A 44
A4	38	B37	40	E51	B 44
A27	45	B38	40	E57	A 44
A29	38	B45	45	E58	B 44
B1	A 45	B46	45	E59	A 44
B2	B 45	E1	42	E60	B 44
B3	C 45	E13	A 42	E61	A 36, 44
B13	39	E14	B 42	E62	B 36, 44
B14	39	E28	43	E63	C 36, 44
B19	39	E46	D 43		

 : **Relay Blocks**

Code	See Page	Relay Blocks (Relay Block Location)
2	22	Engine Room R/B No.2 (Engine Compartment Left)

 : **Junction Block and Wire Harness Connector**

Code	See Page	Junction Block and Wire Harness (Connector Location)
1G	25	Instrument Panel Wire and Driver Side J/B (Lower Finish Panel)
1J		
1K		
1L		
5D	28	Instrument Panel Wire and Center J/B LH (Instrument Panel LH)
5E		
5F		
5J		
5K		
5L		
5M	32	Instrument Panel Wire and Center J/B RH (Instrument Panel RH)
6B		
6C		
6D		
6F		
6G		

 : **Connector Joining Wire Harness and Wire Harness**

Code	See Page	Joining Wire Harness and Wire Harness (Connector Location)
BE1	51	Engine Wire and Instrument Panel Wire (Upper the Glove Box)
BE2		
EA2	51	Instrument Panel Wire and Engine Room Main Wire (Left Kick Panel)
EA4		
EE1	51	Instrument Panel Wire and Instrument Panel Wire (Instrument Panel RH)

 : **Ground Points**

Code	See Page	Ground Points Location
A1	50	Left Fender Apron
B1	50	Rear Side of Right Bank Cylinder Block
B2		
B3	50	Rear Side of Left Bank Cylinder Block
B4		
E2	51	Instrument Panel Brace LH
E4	51	Left Kick Panel

Cruise Control

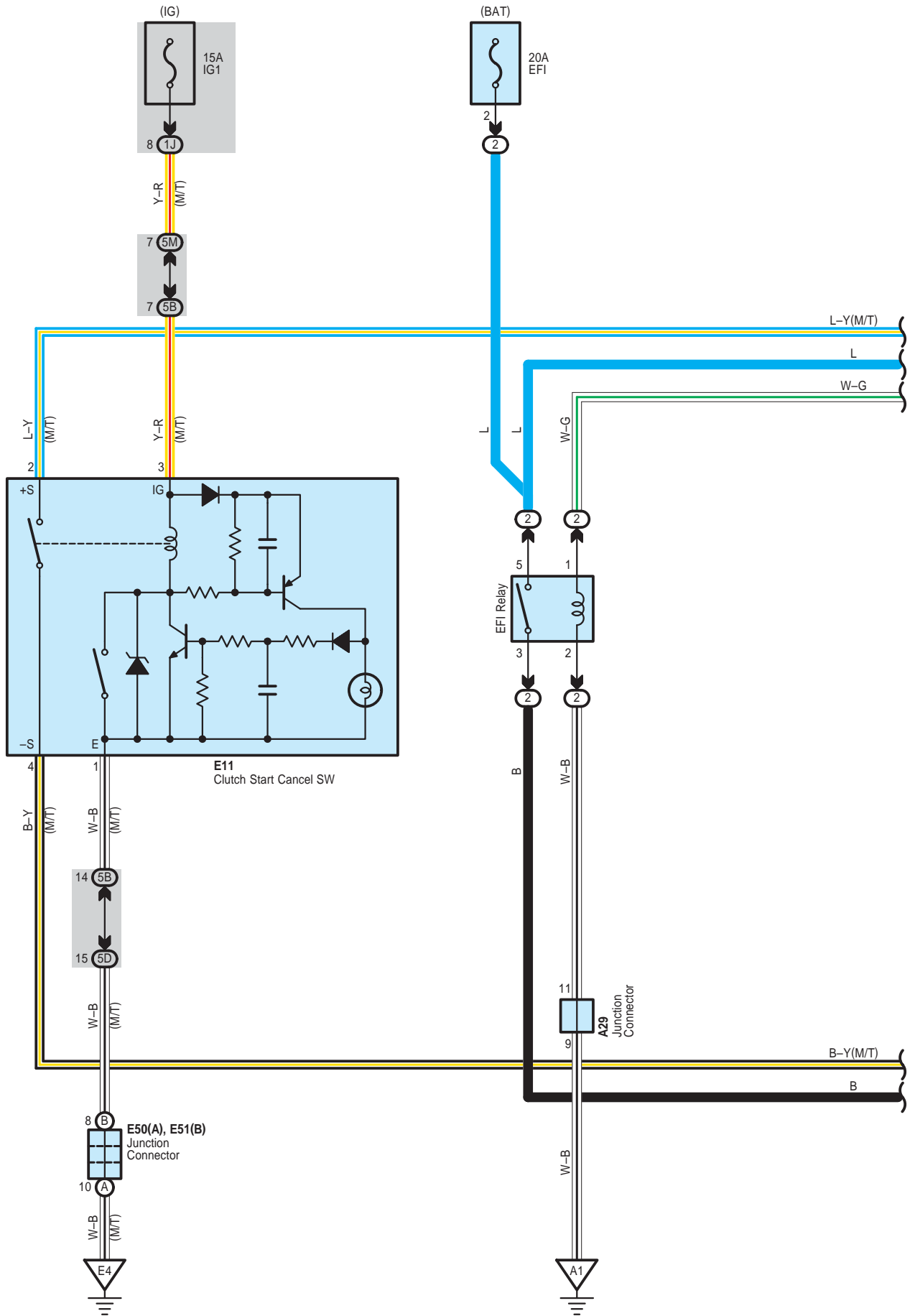

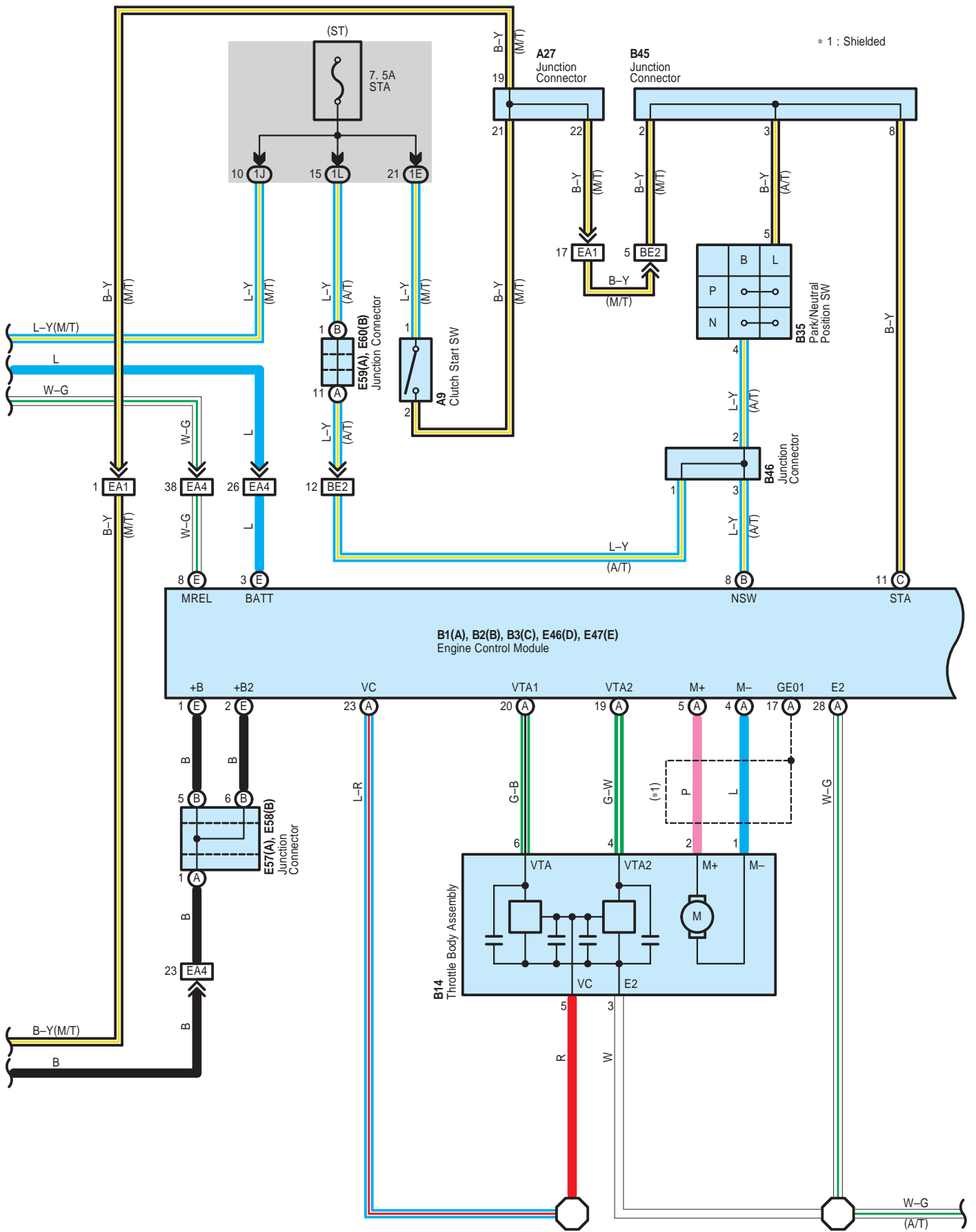

Cruise Control

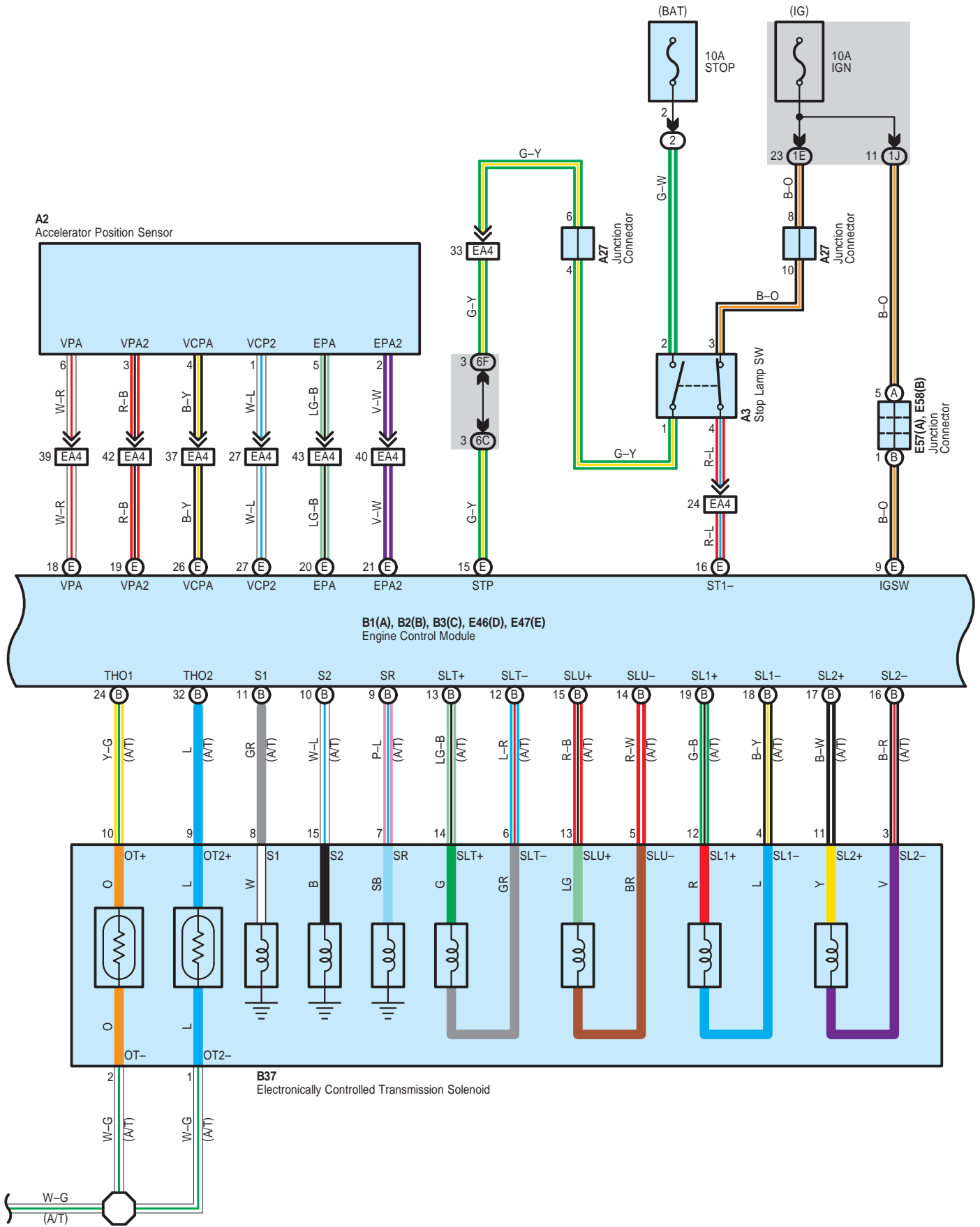

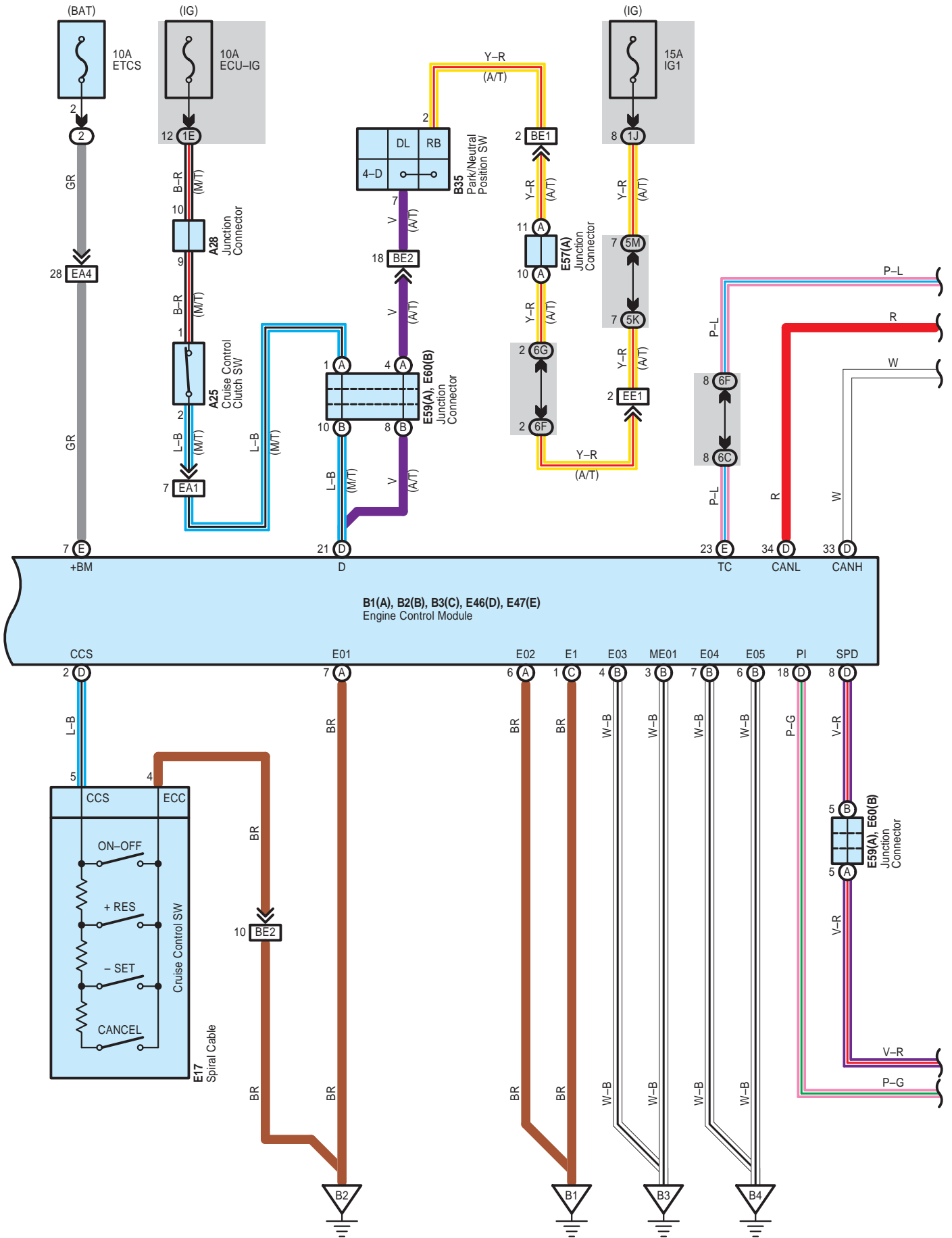

Cruise Control

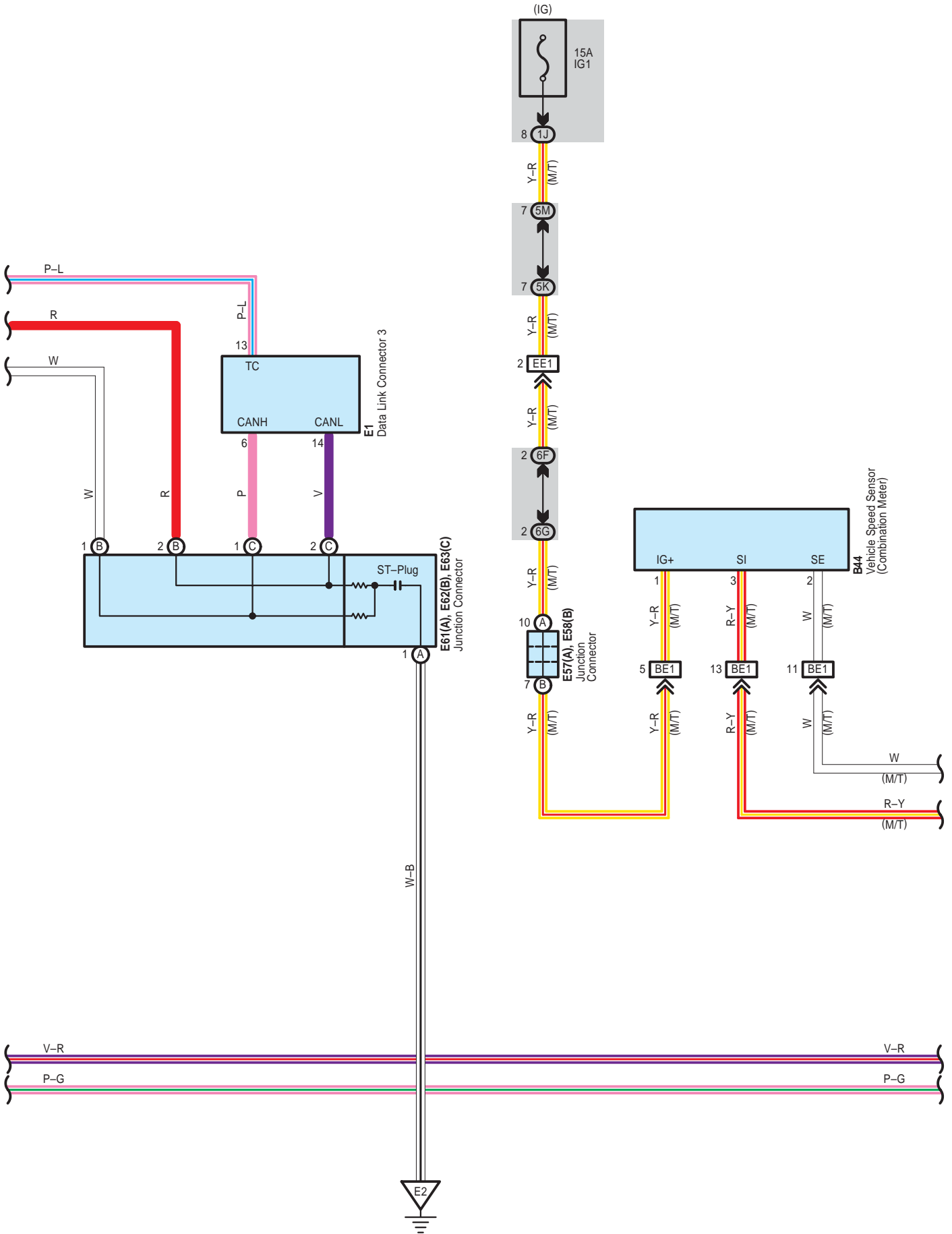

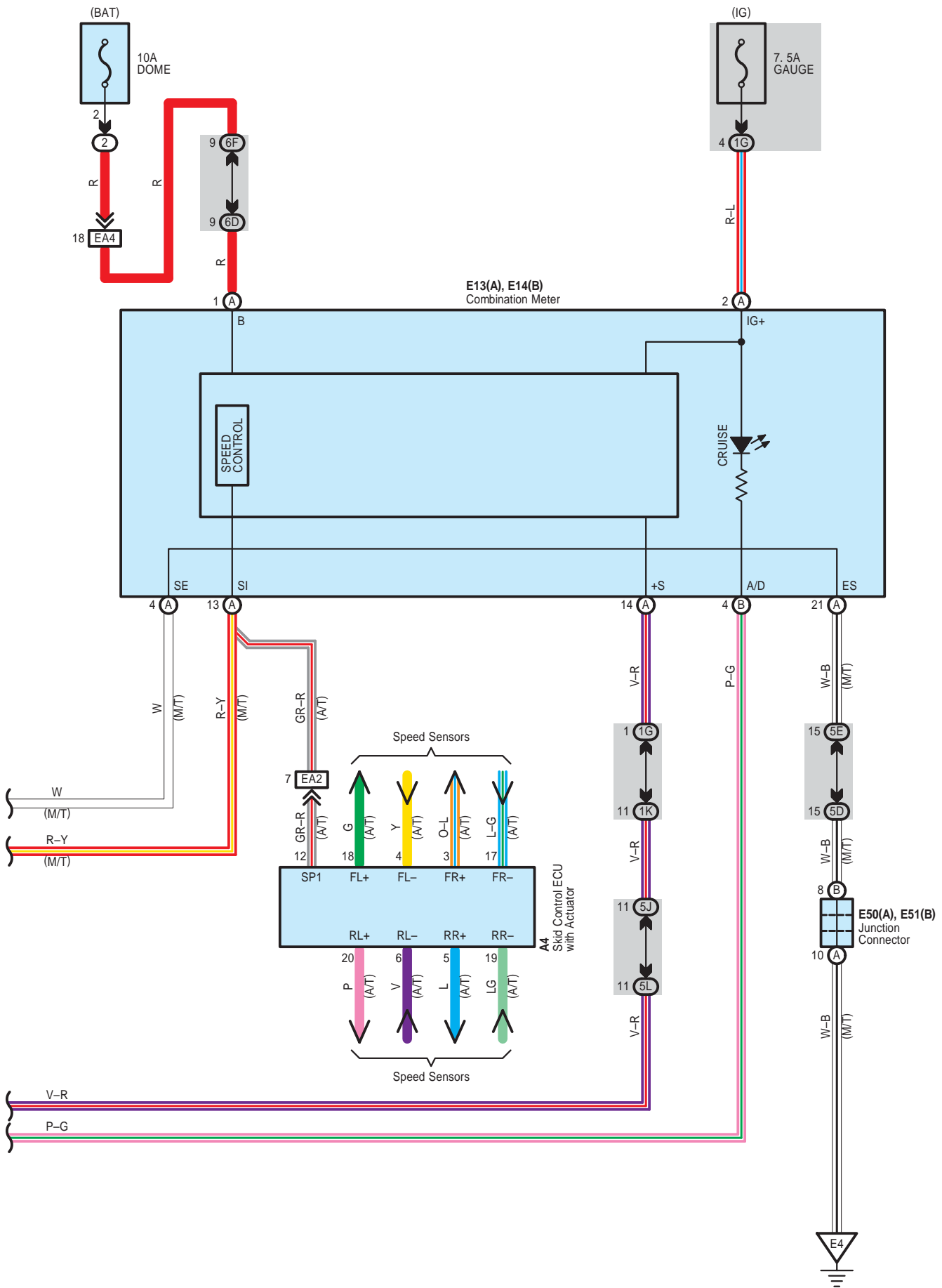

Cruise Control

System Outline

The cruise control system is a constant vehicle speed controller in which the opening of the engine throttle valve is adjusted automatically with control of the SW at hand without depressing the accelerator pedal when a driver wishes to drive at a constant speed on a highway.

1. Constant Speed Control

When actual vehicle speed is faster than the set vehicle speed, a signal is sent to the electric throttle motor to rotate in order to close the throttle valve. On the contrary, when the vehicle speed is slower than the set vehicle speed, a signal is sent to the electric throttle motor to rotate in order to open the throttle valve.

2. Setting

When operating the – SET SW with the ON–OFF SW ON (Within the settable range of the vehicle speed: Above the low speed limit and below the high speed limit), the vehicle speed at which the SW is turned OFF is stored in the memory and the vehicle is controlled to drive constantly at that speed.

3. Coast, Tap Down

<Coast>

When the – SET SW is kept ON during driving under the cruise control, the coast control makes the cruise control request opening 'Zero' (Note: the throttle valve is not completely closed due to idle speed control, etc.) to decelerate and stores the vehicle speed in the memory at which the SW is turned OFF and controls the vehicle to drive constantly at that speed.

<Tap down>

When the – SET SW is turned ON momentarily (Approx. 0.6 sec.), the set vehicle speed decelerates in approximately 1.6 km/h steps by each SW operation. In the tap down operation with more than 5 km/h difference between the set vehicle speed and actual vehicle speed, the vehicle speed at which the SW is turned OFF is stored in the memory and the vehicle is controlled to drive constantly at that speed.

4. Acceleration, Tap Up

<Acceleration>

When the + RES SW is kept ON during driving under the cruise control, the acceleration control rotates the electric throttle motor to open the throttle valve to control the vehicle to accelerate with constant acceleration. The vehicle speed at which the SW is turned OFF is stored in the memory and the vehicle is controlled to drive constantly at that speed.

<Tap up>

When the + RES SW is turned ON momentarily (Approx. 0.6 sec.), the set vehicle speed accelerates in approximately 1.6 km/h steps by each SW operation. When difference between the set vehicle speed and actual vehicle speed is more than 5 km/h, the tap up operation does not change the set vehicle speed.

5. Low Speed Limit

It means the lower limit speed in the settable speed range and is set to be approximately 40 km/h. The cruise control cannot be set if the vehicle speed is slower than the low speed limit. When the vehicle speed drops below the low speed limit during driving under the cruise control, the cruise control is cancelled but the set speed is retained to be available.

6. High Speed Limit

It means the higher limit speed in the settable speed range and is set to be approximately 200 km/h. The cruise control cannot be set if the vehicle speed is faster than the high speed limit. The vehicle cannot be accelerated above the high speed limit with the + RES SW operation.

7. Cancel

When the following signals are input during driving under the cruise control, the cruise control is cancelled.

- (1) Stop lamp SW ON
- (2) CANCEL SW ON in the control SW
- (3) ON–OFF SW OFF
- (4) D position circuit ON to OFF in the park/neutral position SW (Shift position is shifted from D, 4 to N, 3, 2, L.) (A/T)
- (5) Cruise control clutch SW OFF (Clutch pedal depressed) (M/T)

8. Resume

When the vehicle speed stays at more than the low speed limit after the cruise control is canceled with above signals (Except (3) ON–OFF SW OFF), the cruise control resumes operation to reach the vehicle speed that was set at the time the driver canceled the cruise control with constant acceleration by operating the + RES SW from OFF to ON.

9. Over Drive Control

During driving with cruise control, the overdrive function might be released on climbing hills. When climbing hill is judged to finish from throttle opening information, the overdrive function is returned after the overdrive resume timer. If the overdrive function is cut during acceleration or resume control, the overdrive function is returned after acceleration or resume control is completed.

10. Auto Cancel

- (1) The set vehicle speed is erased in the memory and the cruise control is cancelled in the following conditions. Until the ON-OFF SW is turned ON again, the cruise operation indicator blinks and the control will not be effective.
 - * When the stop lamp SW is disconnected and short-circuit.
 - * When the vehicle speed signal is abnormal
 - * When the electronic throttle parts are abnormal
- (2) The set vehicle speed is erased in the memory and the cruise control is cancelled in the following conditions. Until the ON-OFF SW is turned ON again, the cruise operation indicator blinks and the control will not be effective unless the ignition SW is turned OFF.
 - * When the stop lamp SW input circuit is abnormal
 - * When the cancel circuit is abnormal
- (3) The set vehicle speed is erased in the memory and the cruise control is cancelled in the following conditions.
 - * When the vehicle speed drops below the speed which is the set speed minus 16km/h. (Set speed erased)
- (4) The cruise control is cancelled in the following conditions.
 - * When the vehicle speed is slower than the low speed limit. (Set speed retained)

○ : Parts Location

Code		See Page	Code		See Page	Code		See Page
A2		45	B14		39	E46	D	43
A3		45	B35		40	E47	E	43
A4		38	B37		40	E50	A	44
A9		45	B44		40	E51	B	44
A25		45	B45		45	E57	A	44
A27		45	B46		45	E58	B	44
A28		38	E1		42	E59	A	44
A29		38	E11		42	E60	B	44
B1	A	45	E13	A	42	E61	A	36, 44
B2	B	45	E14	B	42	E62	B	36, 44
B3	C	45	E17		42	E63	C	36, 44

○ : Relay Blocks

Code	See Page	Relay Blocks (Relay Block Location)
2	22	Engine Room R/B No.2 (Engine Compartment Left)

Cruise Control

: Junction Block and Wire Harness Connector

Code	See Page	Junction Block and Wire Harness (Connector Location)
1E	24	Engine Room Main Wire and Driver Side J/B (Lower Finish Panel)
1G	25	Instrument Panel Wire and Driver Side J/B (Lower Finish Panel)
1J		
1K		
1L		
5B		
5D	28	Instrument Panel Wire and Center J/B LH (Instrument Panel LH)
5E		
5J		
5K		
5L		
5M		
6C	32	Instrument Panel Wire and Center J/B RH (Instrument Panel RH)
6D		
6F		
6G		

: Connector Joining Wire Harness and Wire Harness

Code	See Page	Joining Wire Harness and Wire Harness (Connector Location)
BE1	51	Engine Wire and Instrument Panel Wire (Upper the Glove Box)
BE2		
EA1	51	Instrument Panel Wire and Engine Room Main Wire (Left Kick Panel)
EA2		
EA4		
EE1	51	Instrument Panel Wire and Instrument Panel Wire (Instrument Panel RH)

: Ground Points

Code	See Page	Ground Points Location
A1	50	Left Fender Apron
B1	50	Rear Side of Right Bank Cylinder Block
B2		
B3	50	Rear Side of Left Bank Cylinder Block
B4		
E2	51	Instrument Panel Brace LH
E4	51	Left Kick Panel

ABS, TRAC, VSC and Auto LSD

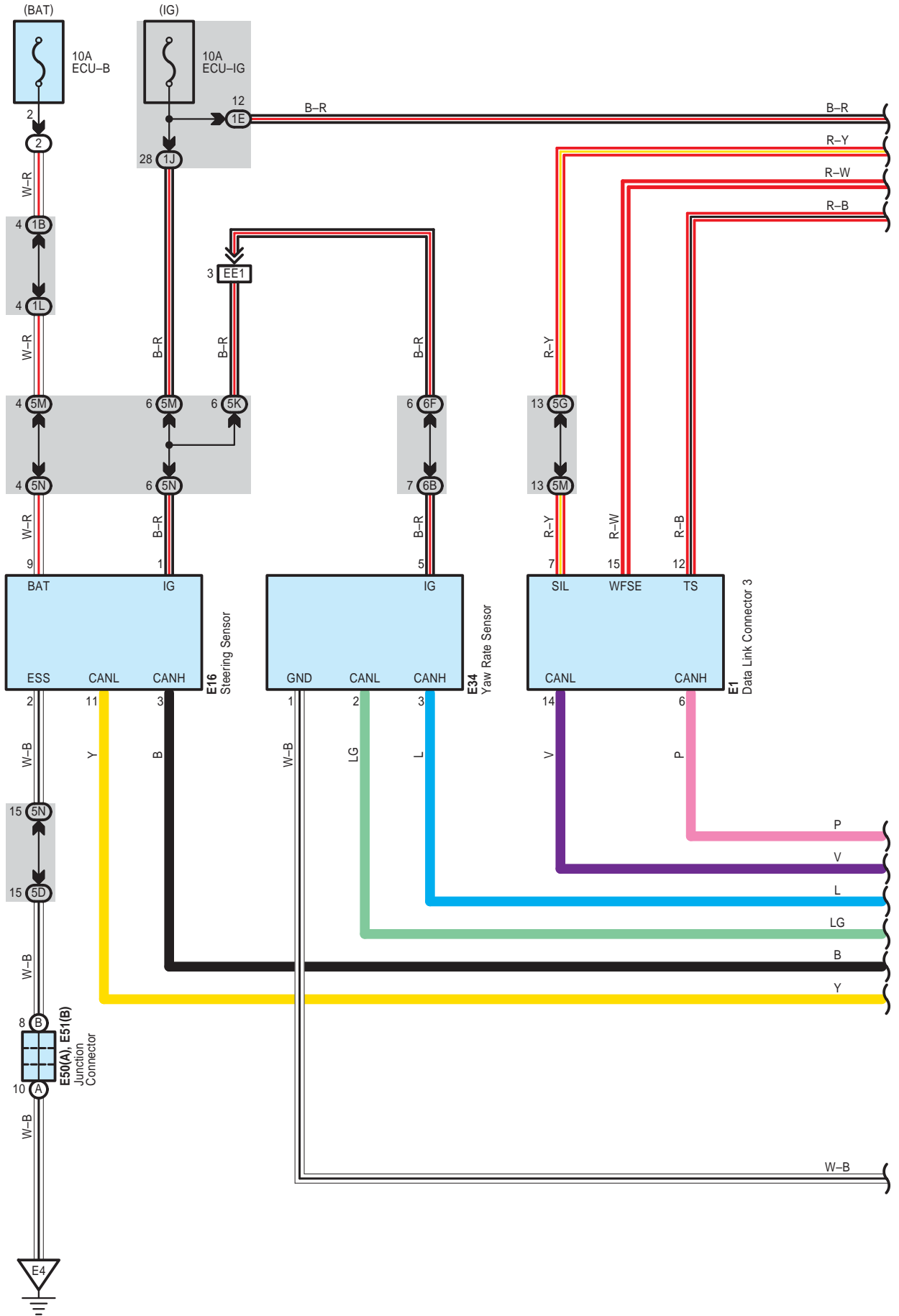

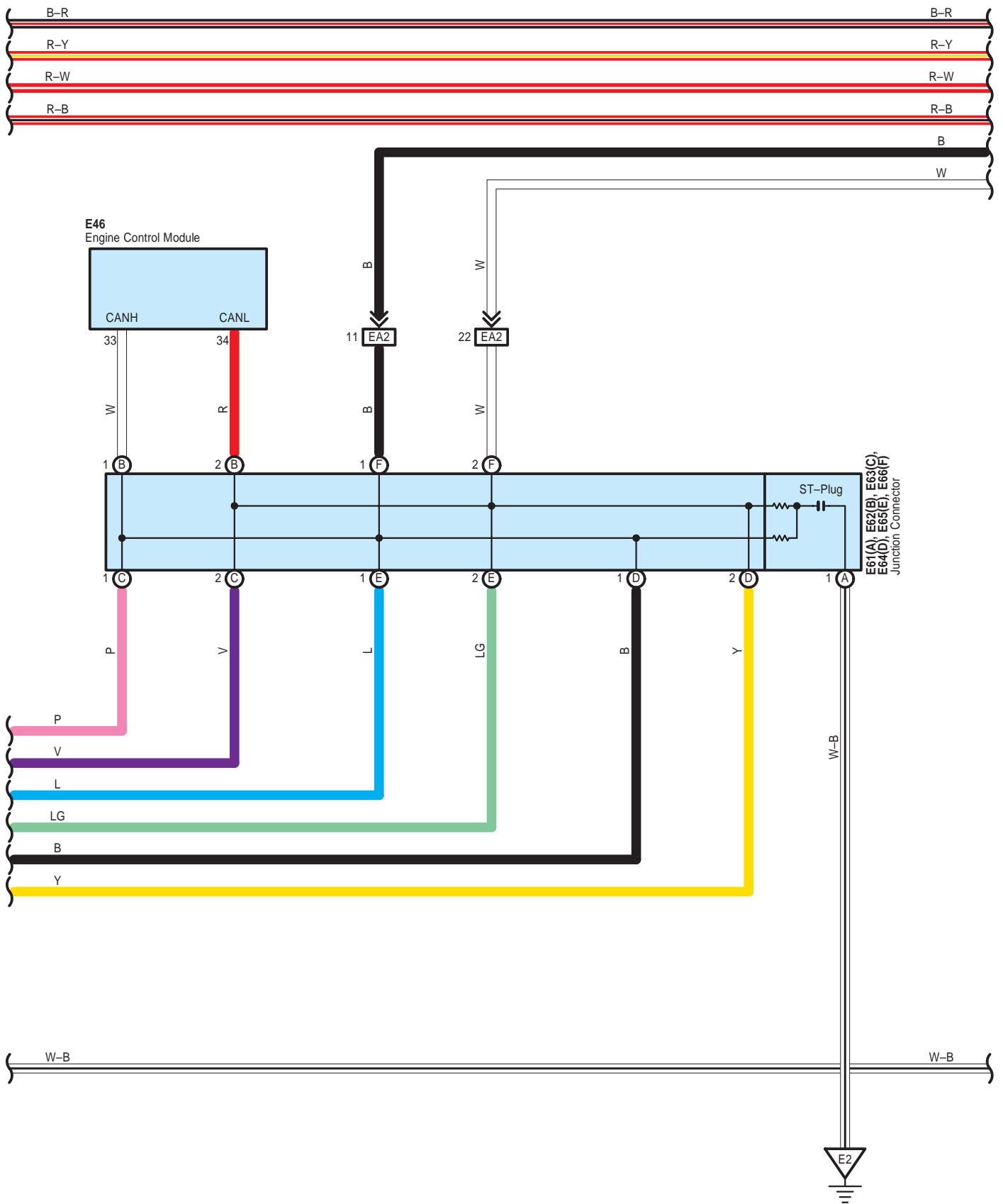

ABS, TRAC, VSC and Auto LSD

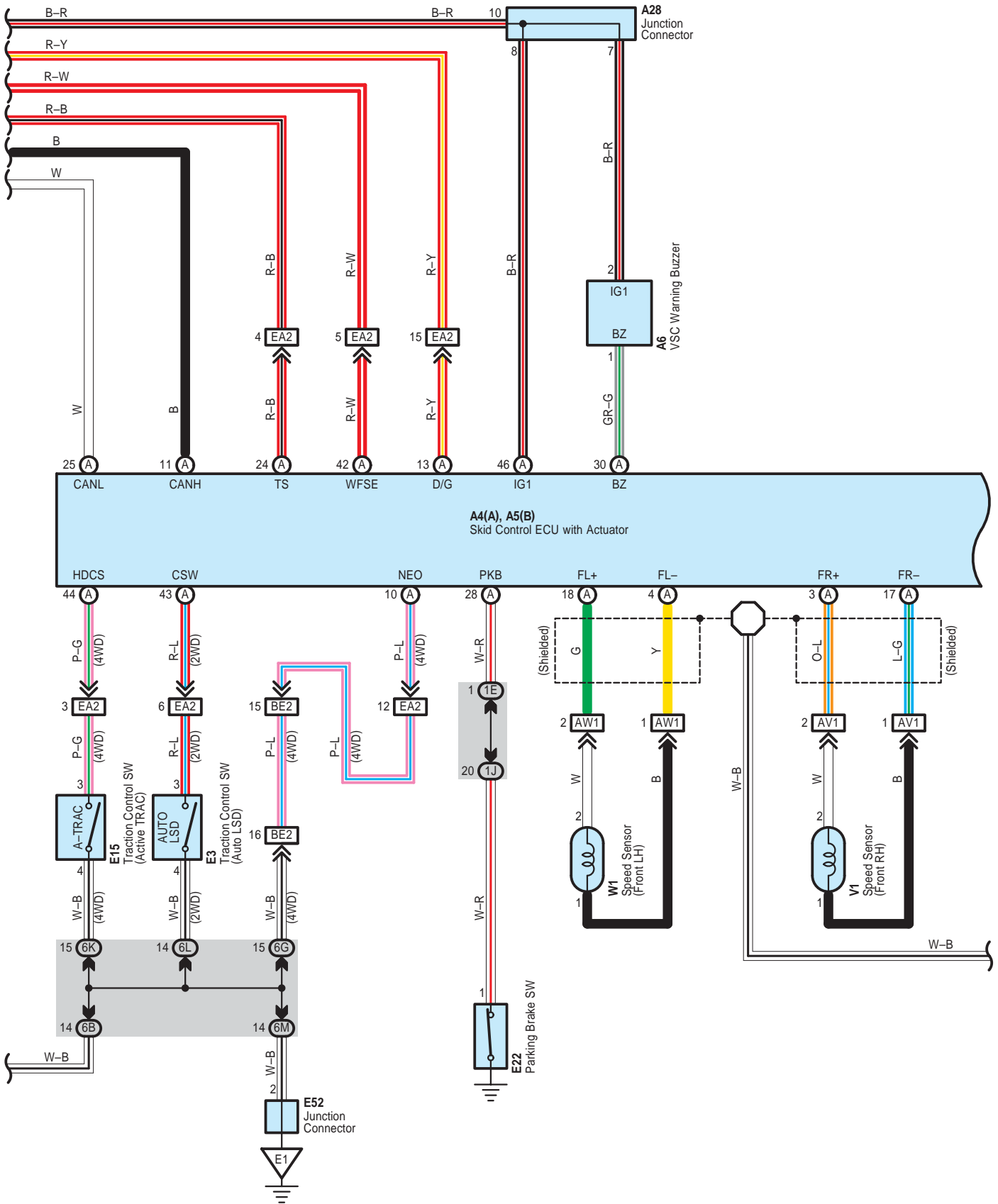

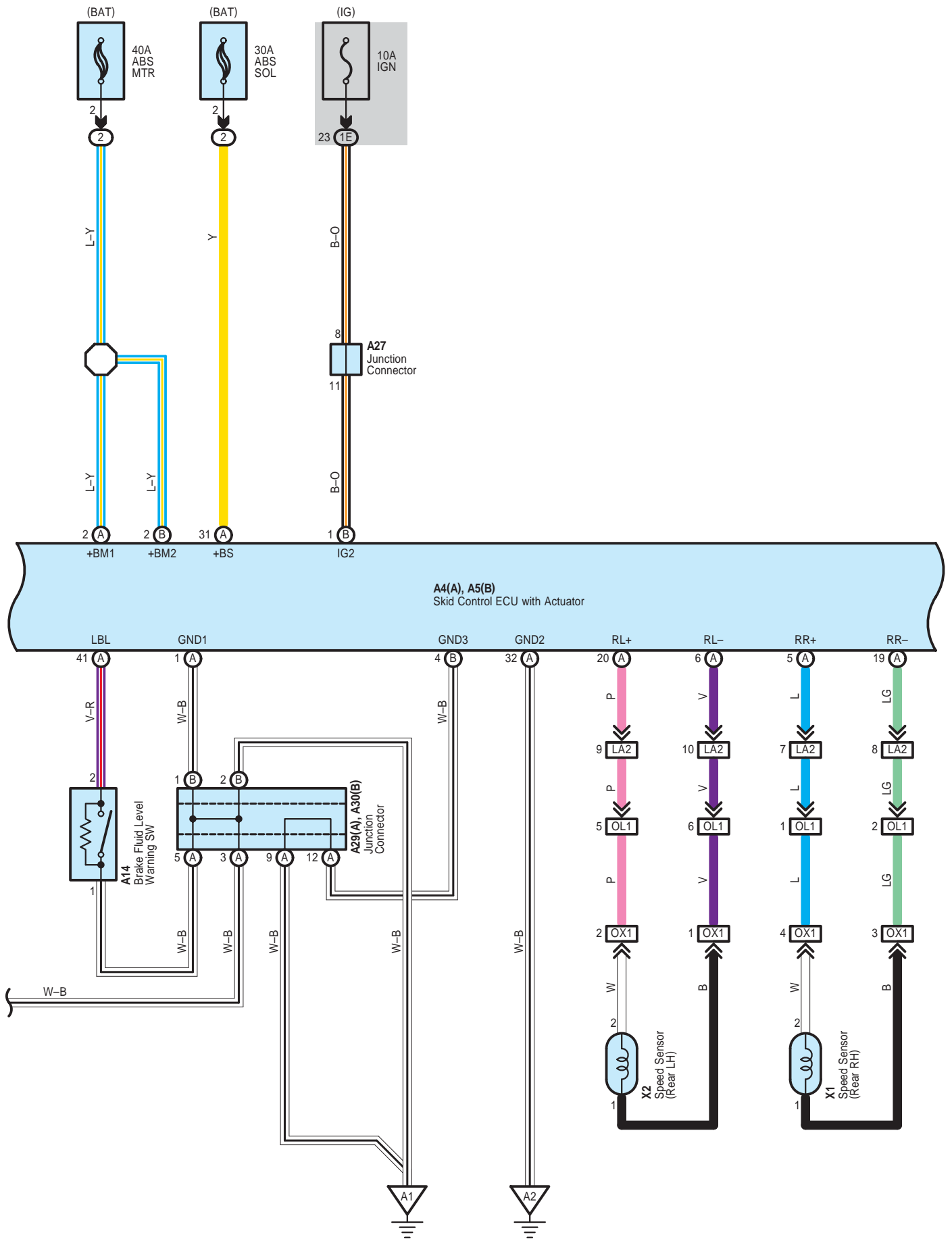

ABS, TRAC, VSC and Auto LSD

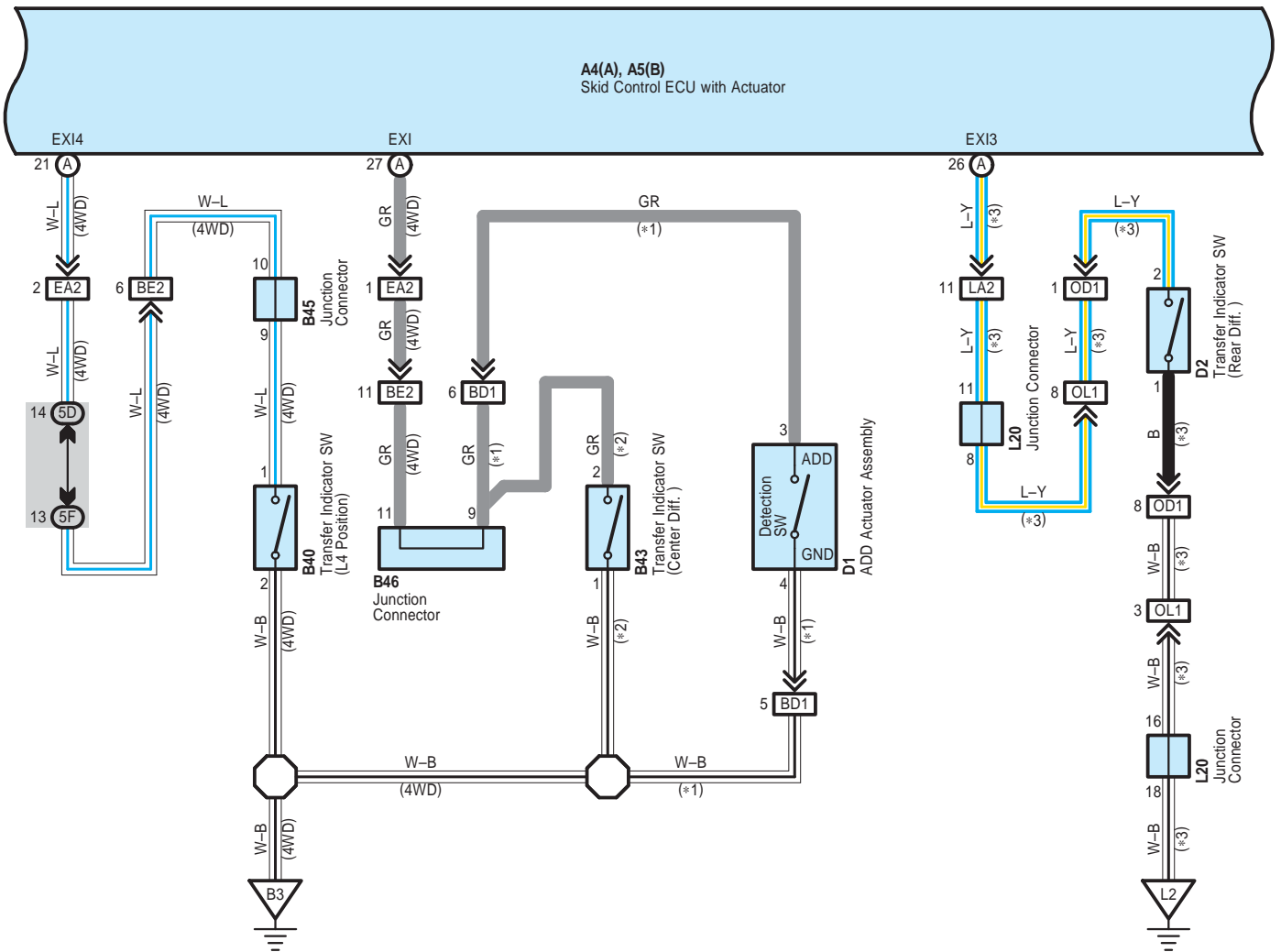

- * 1 : A/T 4WD
- * 2 : M/T 4WD
- * 3 : w/ Rear Diff. Lock
- * 4 : 4WD, 2WD w/ Rear Diff. Lock

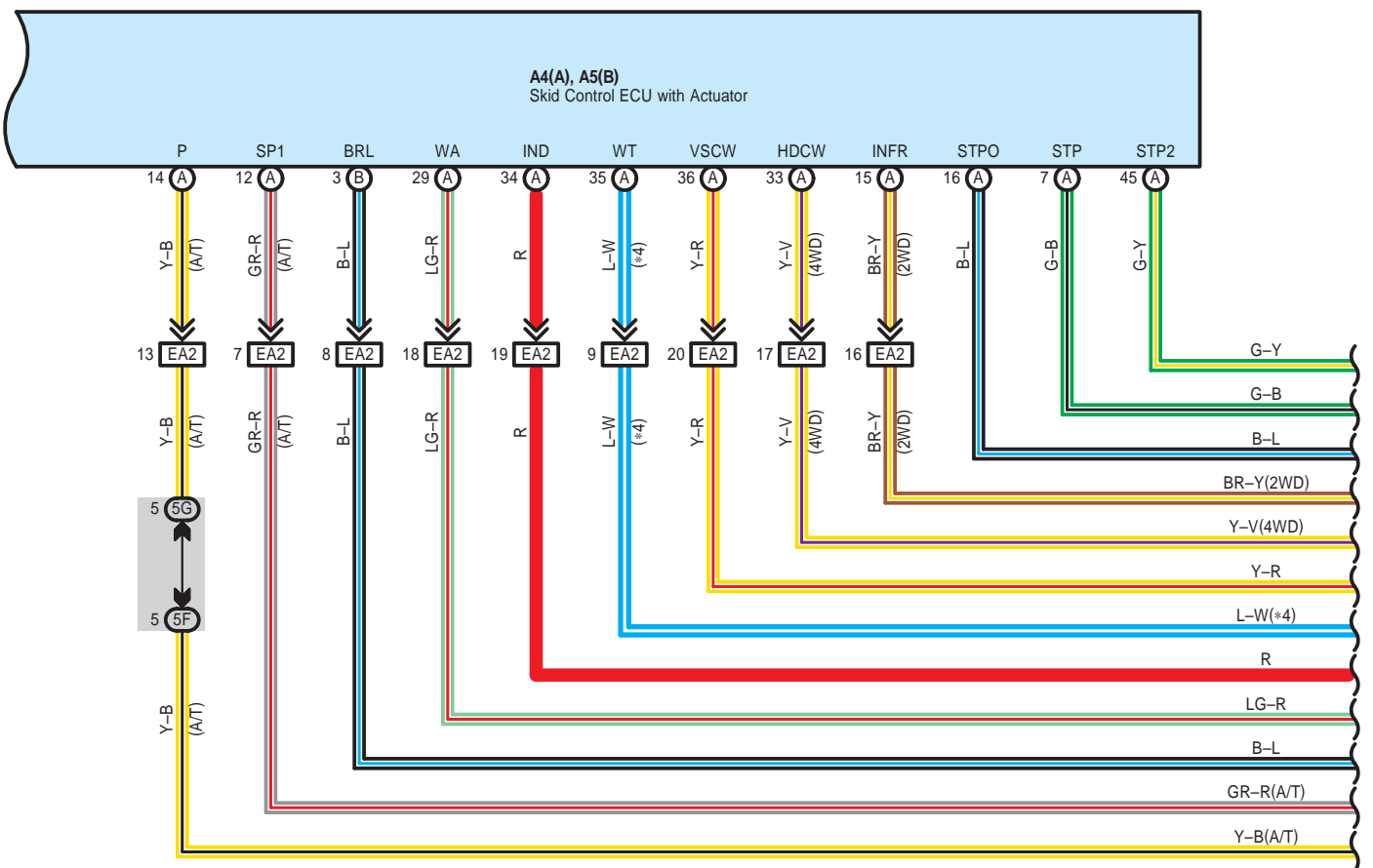

ABS, TRAC, VSC and Auto LSD

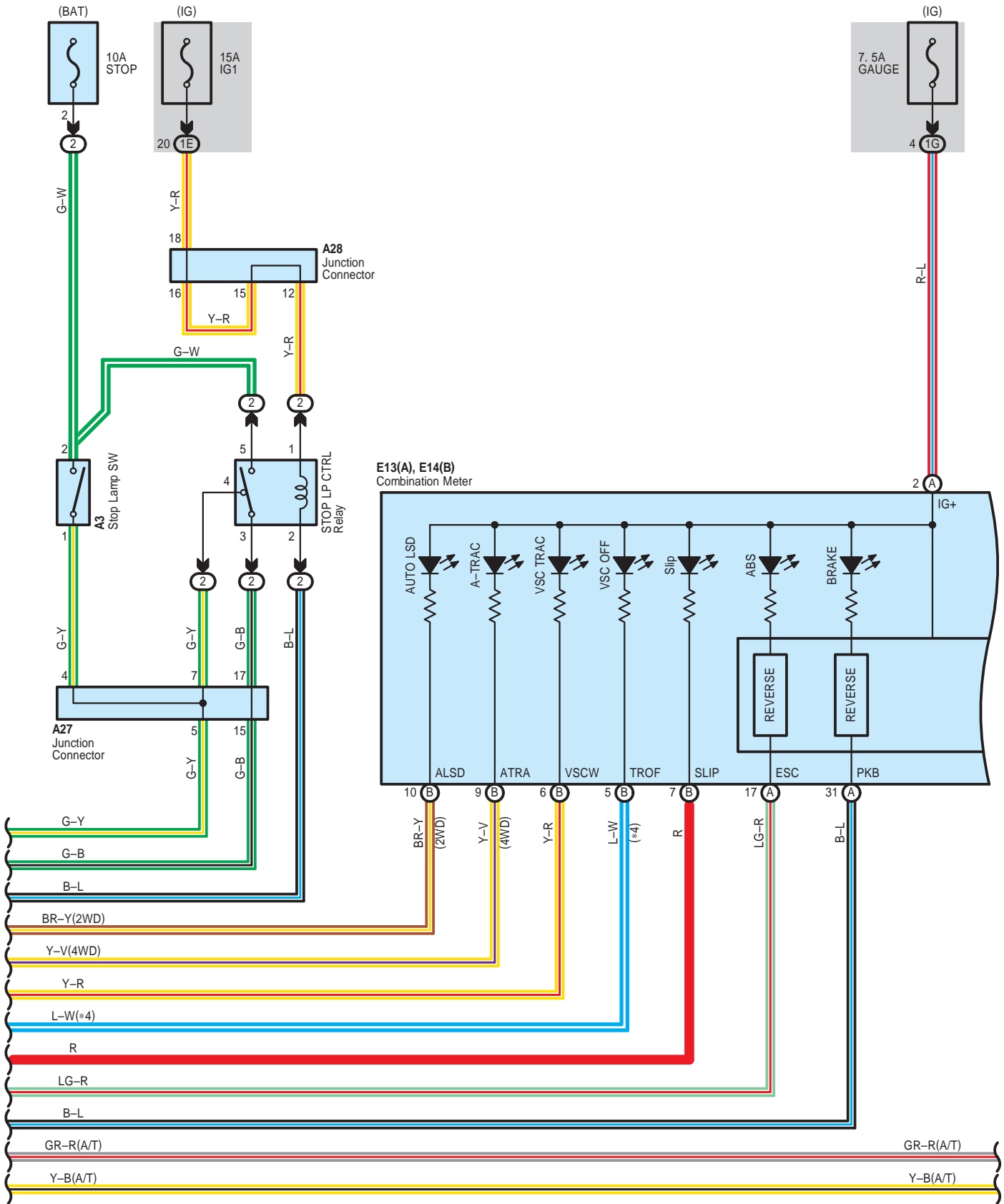

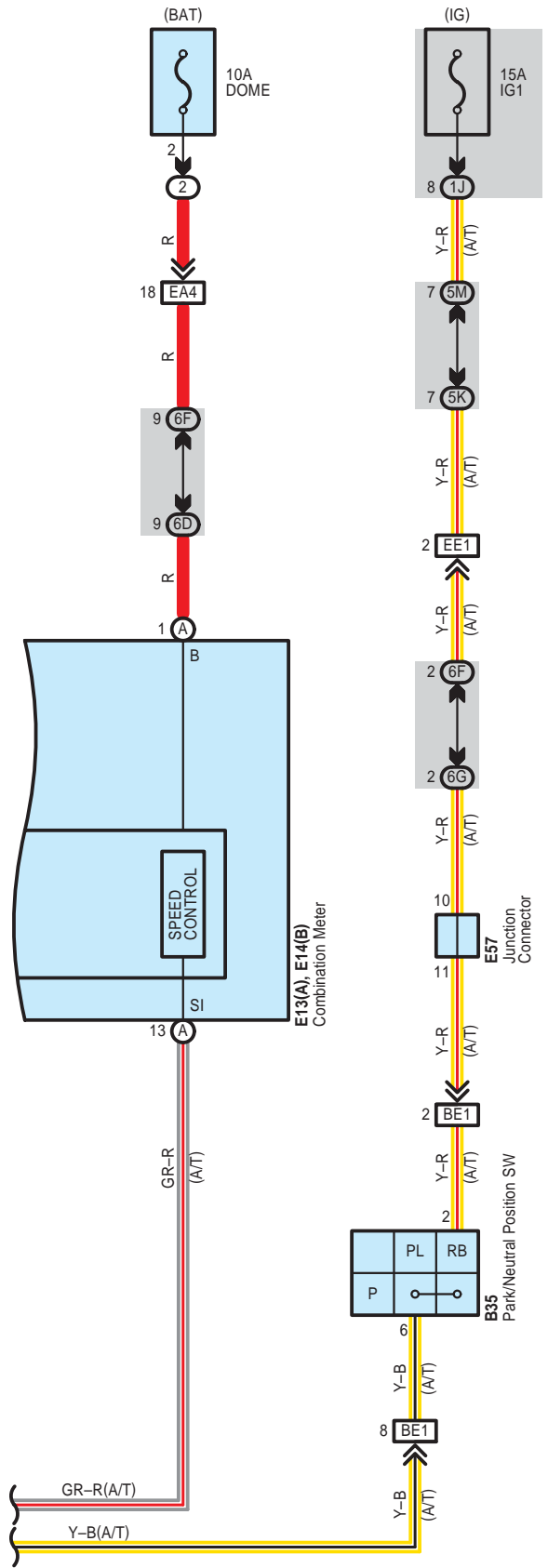

* 4 : 4WD, 2WD w/ Rear Diff. Lock

ABS, TRAC, VSC and Auto LSD

System Outline

1. VSC (Vehicle Stability Control)

It is a system to prevent unstable behavior of the vehicle by controlling the brake of each wheel and engine output automatically after detecting skid caused by sudden steering operation and on slippery roads with the sensors.

VSC is not a system to enhance vehicle's marginal performance but to return the vehicle state back to the stable operation range when it enters in the operation marginal range.

2. ABS with EBD (Electronic Brake Force Distribution)

ABS detects the wheel speed at braking and prevents the tire lock at braking by controlling brake fluid pressure of the four wheels automatically. It is a system to ensure vehicle's stability and steering effect. By preventing the tire lock, cornering force is used efficiently.

ABS is effective to avoid the risk when the vehicle is steered during braking and the spin when the vehicle is braked with one side wheels on icy road and the other on asphalt road.

Besides conventional ABS functions, ABS with EBD controls appropriate brake force distribution between front and rear wheels, and left and right wheels regardless of load change such as vehicle weight with and without load, which ensures good braking performance

3. Brake Assist

The brake assist system interprets a quick push of the brake pedal as emergency braking and supplements the brake power applied if the driver has not stepped hard enough on the brake pedal.

4. Active TRAC (4WD)

In active traction control system, brake fluid pressure is controlled on slipped wheels by acceleration with 4WD in off-road driving and driving force which may be lost by acceleration slip is distributed to each wheels, resulting in excellent LSD effect.

5. TRAC

It is a function to ensure vehicle stability and driving force by preventing the drive wheels from slipping when starting off or accelerating on a slippery surface by controlling the brake fluid pressure and engine output automatically.

6. Auto LSD (2WD)

Auto LSD fulfills LSD functions by using the TRAC system. Comparing with TRAC, it controls focusing on how easily the vehicle can get out of the stuck condition and ensures to get out when one tire comes off the ground and to start off on roads with large travel resistance such as sandy roads.

○ : Parts Location

Code	See Page	Code	See Page	Code	See Page
A3	45	D1	41	E57	44
A4	A 38	D2	47	E61	A 36, 44
A5	B 38	E1	42	E62	B 36, 44
A6	45	E3	42	E63	C 36, 44
A14	38	E13	A 42	E64	D 36, 44
A27	45	E14	B 42	E65	E 36, 44
A28	38	E15	42	E66	F 36, 44
A29	A 38	E16	42	L20	46
A30	B 38	E22	42	V1	41
B35	40	E34	43	W1	41
B40	40	E46	43	X1	47
B43	40	E50	A 44	X2	47
B45	45	E51	B 44		
B46	45	E52	44		

○ : Relay Blocks

Code	See Page	Relay Blocks (Relay Block Location)
2	22	Engine Room R/B No.2 (Engine Compartment Left)

 : Junction Block and Wire Harness Connector

Code	See Page	Junction Block and Wire Harness (Connector Location)
1B	24	Engine Room Main Wire and Driver Side J/B (Lower Finish Panel)
1E		
1G	25	Instrument Panel Wire and Driver Side J/B (Lower Finish Panel)
1J		
1L		
5D	28	Instrument Panel Wire and Center J/B LH (Instrument Panel LH)
5F		
5G		
5K		
5M		
5N		
6B	32	Instrument Panel Wire and Center J/B RH (Instrument Panel RH)
6D		
6F		
6G		
6K		
6L		
6M		

 : Connector Joining Wire Harness and Wire Harness

Code	See Page	Joining Wire Harness and Wire Harness (Connector Location)
AV1	50	Engine Room Main Wire and Skid Control Sensor Front RH Wire (Right Fender Apron)
AW1	50	Engine Room Main Wire and Skid Control Sensor Front LH Wire (Near the Engine Room R/B No.2)
BD1	50	Engine Wire and Differential Wire (Near the Front Differential)
BE1	51	Engine Wire and Instrument Panel Wire (Upper the Glove Box)
BE2		
EA2	51	Instrument Panel Wire and Engine Room Main Wire (Left Kick Panel)
EA4		
EE1	51	Instrument Panel Wire and Instrument Panel Wire (Instrument Panel RH)
LA2	51	Floor No.2 Wire and Engine Room Main Wire (Left Kick Panel)
OD1	52	Frame Wire and Differential Wire (No.6 Crossmember)
OL1	52	Frame Wire and Floor No.2 Wire (Under the Rear Seat)
OX1	52	Frame Wire and Skid Control Sensor Rear Wire (No.5 Crossmember)

 : Ground Points

Code	See Page	Ground Points Location
A1	50	Left Fender Apron
A2	50	Right Fender Apron
B3	50	Rear Side of Left Bank Cylinder Block
E1	51	Instrument Panel Brace RH
E2	51	Instrument Panel Brace LH
E4	51	Left Kick Panel
L2	52	Left Quarter Panel

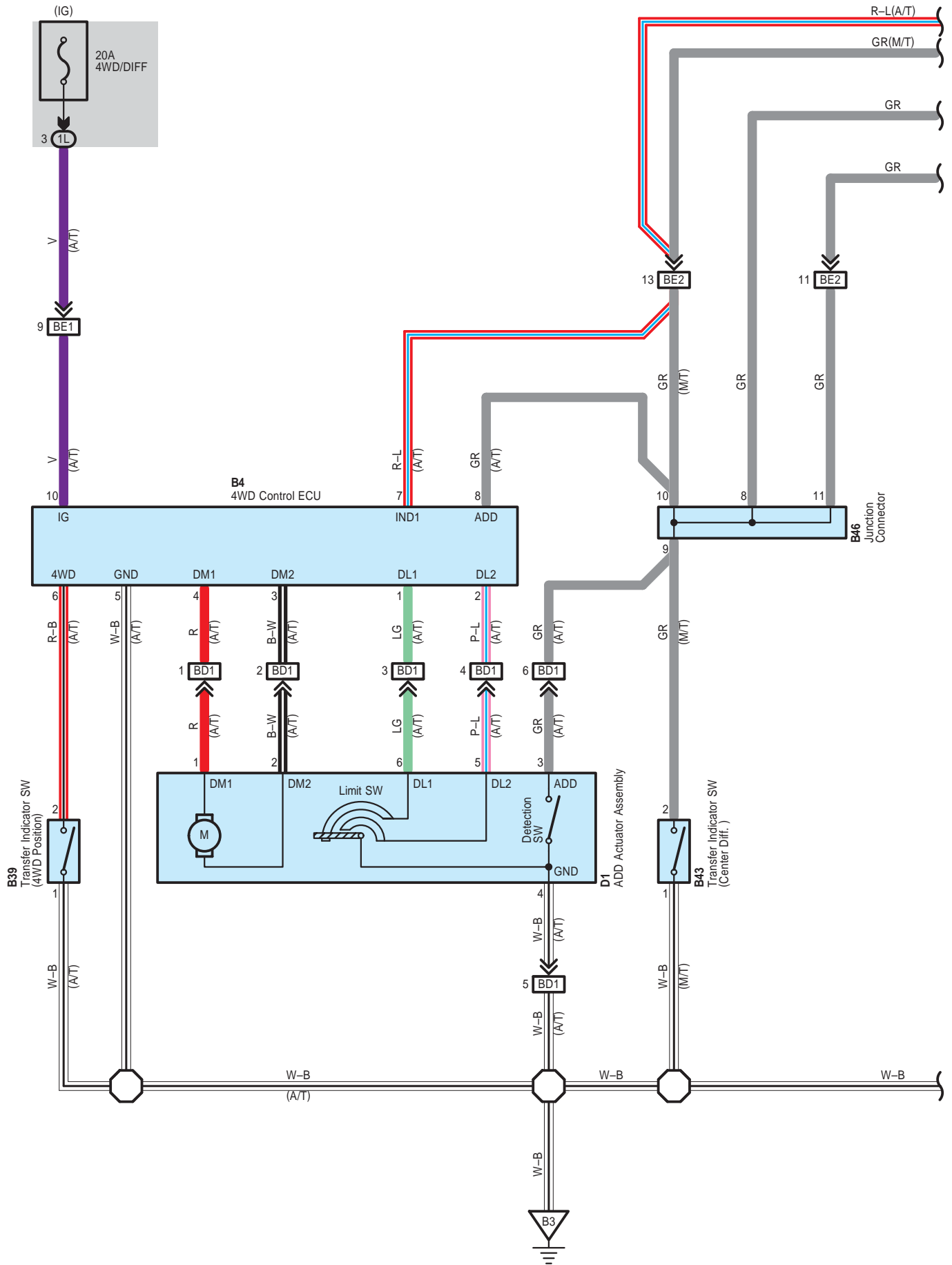

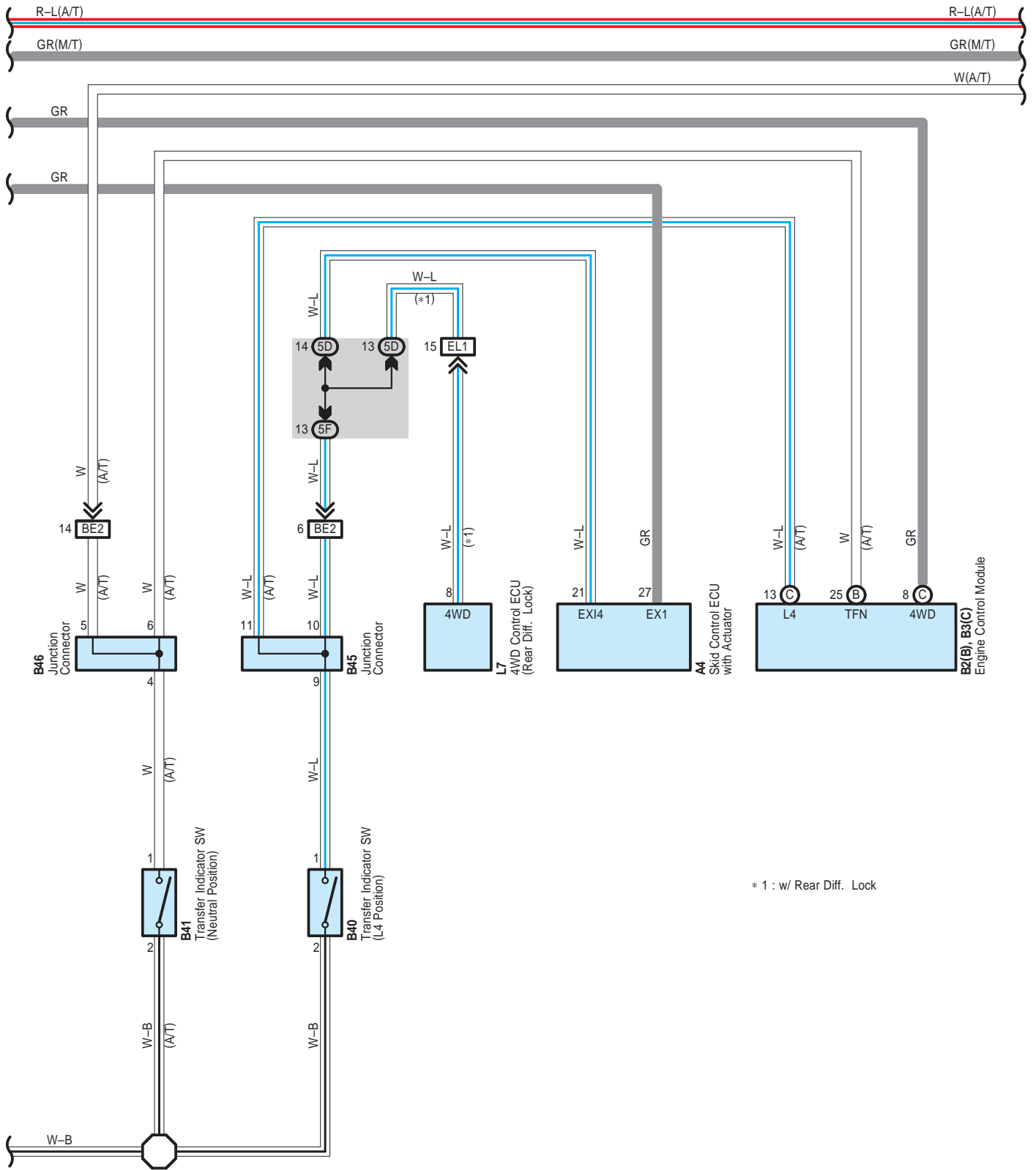

* 1 : w/ Rear Diff. Lock

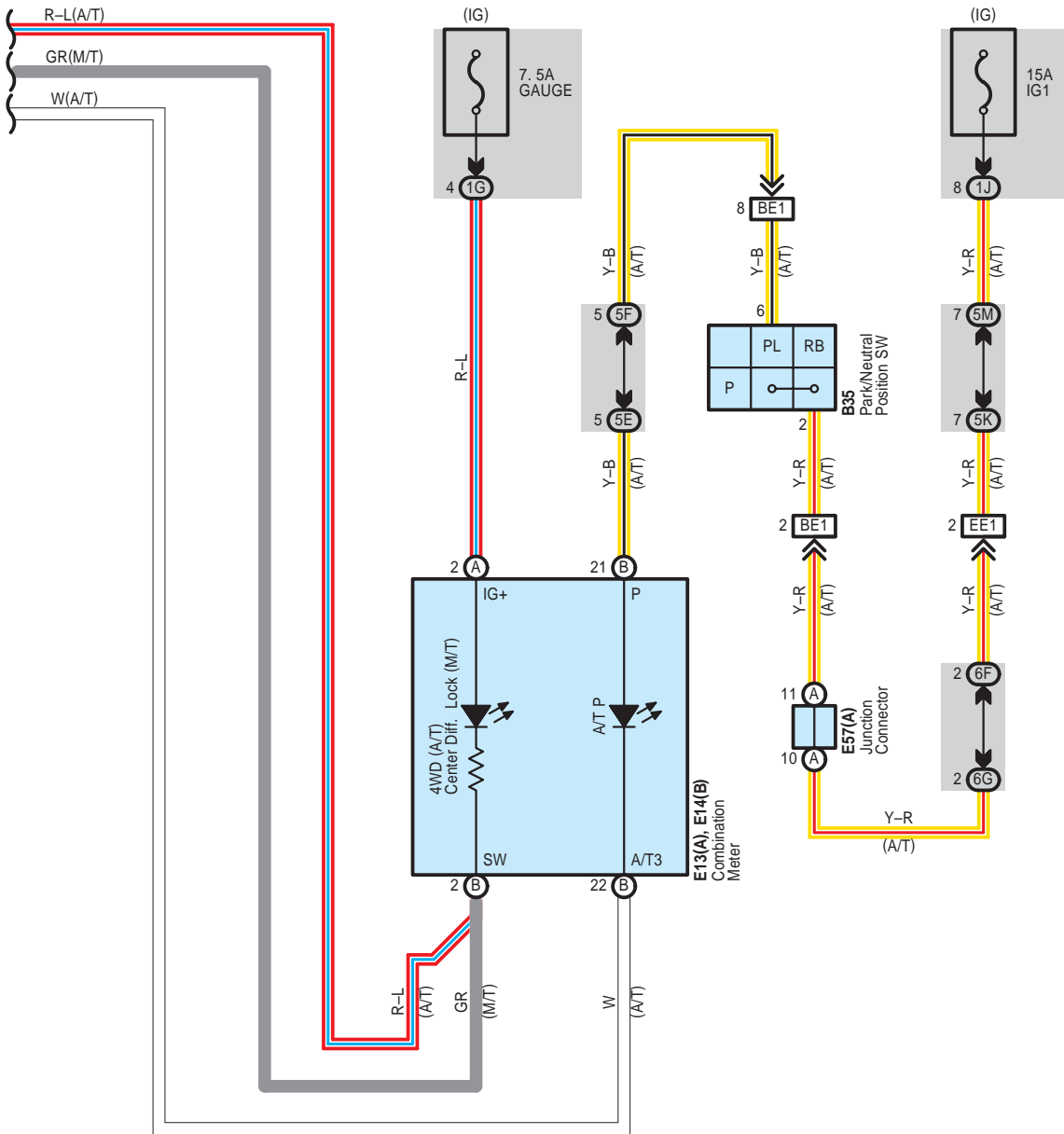

 : **Parts Location**

Code	See Page	Code	See Page	Code	See Page
A4	38	B40	40	E13	A 42
B2	B 45	B41	40	E14	B 42
B3	C 45	B43	40	E57	A 44
B4	45	B45	45	L7	45
B35	40	B46	45		
B39	40	D1	41		

 : **Junction Block and Wire Harness Connector**

Code	See Page	Junction Block and Wire Harness (Connector Location)
1G	25	Instrument Panel Wire and Driver Side J/B (Lower Finish Panel)
1J		
1L		
5D	28	Instrument Panel Wire and Center J/B LH (Instrument Panel LH)
5E		
5F		
5K		
5M	32	Instrument Panel Wire and Center J/B RH (Instrument Panel RH)
6F		
6G		

 : **Connector Joining Wire Harness and Wire Harness**

Code	See Page	Joining Wire Harness and Wire Harness (Connector Location)
BD1	50	Engine Wire and Differential Wire (Near the Front Differential)
BE1	51	Engine Wire and Instrument Panel Wire (Upper the Glove Box)
BE2		
EE1	51	Instrument Panel Wire and Instrument Panel Wire (Instrument Panel RH)
EL1	51	Instrument Panel Wire and Floor No.2 Wire (Left Kick Panel)

 : **Ground Points**

Code	See Page	Ground Points Location
B3	50	Rear Side of Left Bank Cylinder Block

Rear Differential Lock

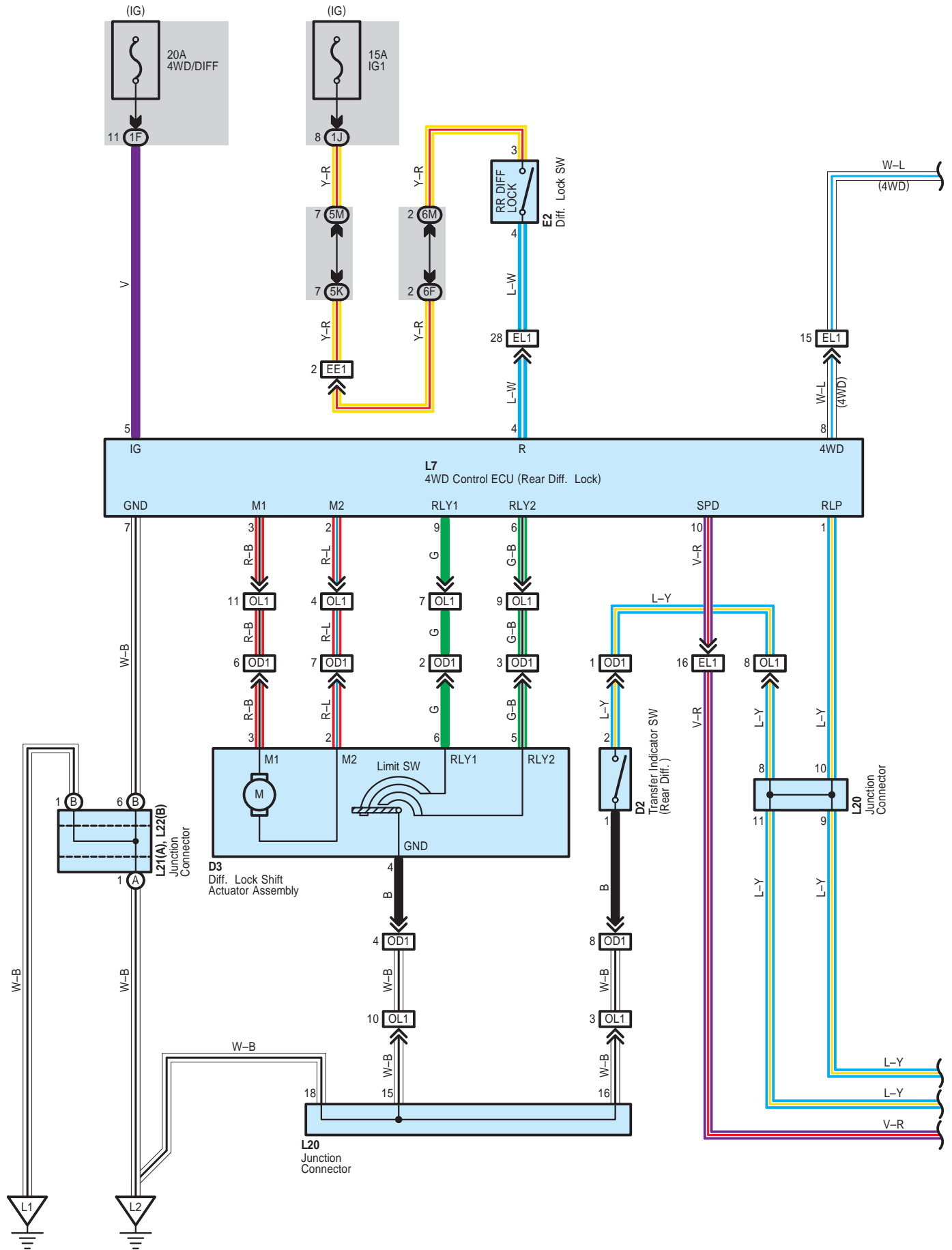

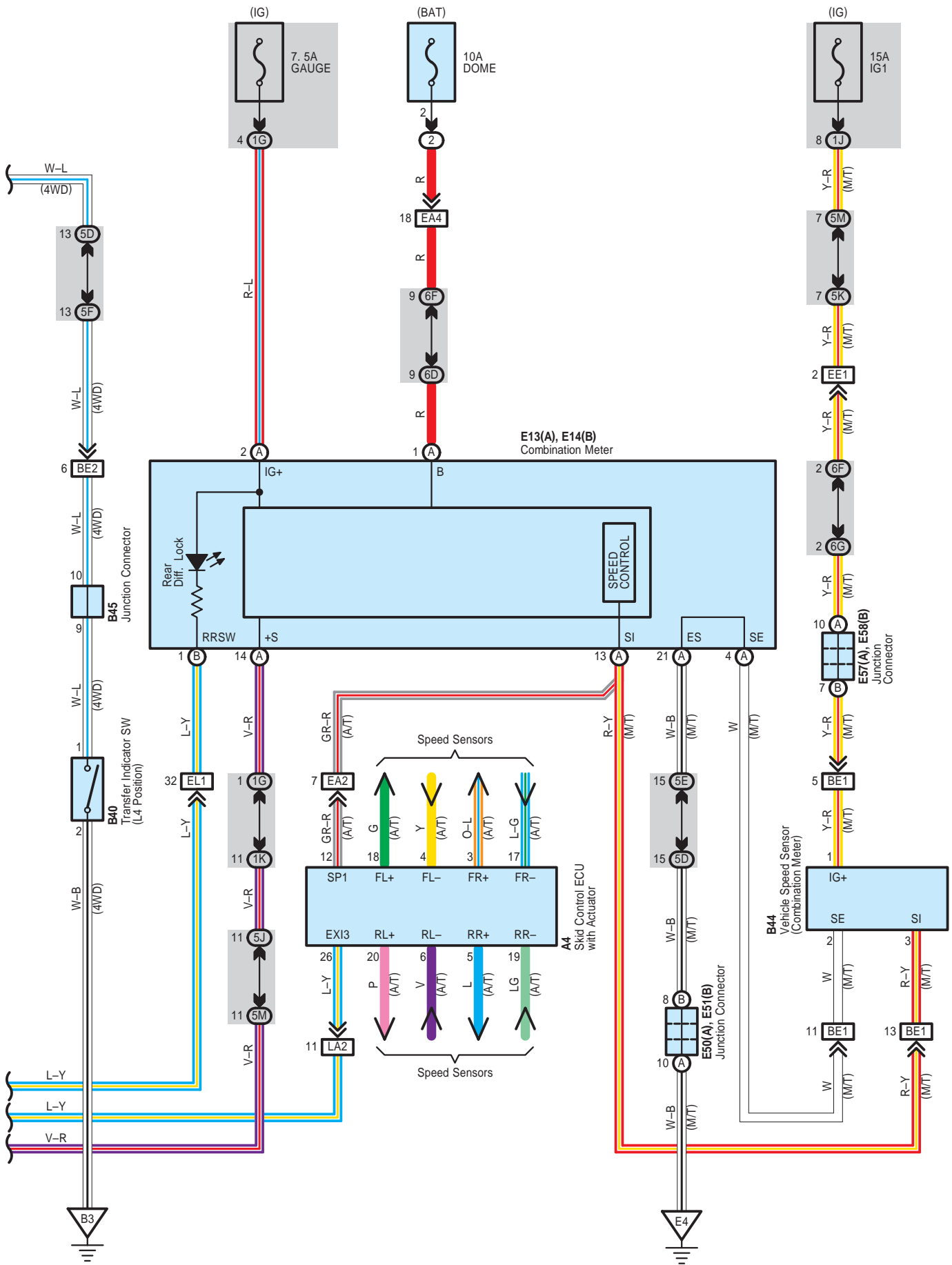

Rear Differential Lock

: Parts Location

Code	See Page	Code	See Page	Code	See Page
A4	38	E2	42	E58	B 44
B40	40	E13	A 42	L7	45
B44	40	E14	B 42	L20	46
B45	45	E50	A 44	L21	A 46
D2	47	E51	B 44	L22	B 46
D3	47	E57	A 44		

: Relay Blocks

Code	See Page	Relay Blocks (Relay Block Location)
2	22	Engine Room R/B No.2 (Engine Compartment Left)

: Junction Block and Wire Harness Connector

Code	See Page	Junction Block and Wire Harness (Connector Location)
1F	24	Floor No.2 Wire and Driver Side J/B (Lower Finish Panel)
1G	25	Instrument Panel Wire and Driver Side J/B (Lower Finish Panel)
1J		
1K		
5D	28	Instrument Panel Wire and Center J/B LH (Instrument Panel LH)
5E		
5F		
5J		
5K		
5M		
6D	32	Instrument Panel Wire and Center J/B RH (Instrument Panel RH)
6F		
6G		
6M		

: Connector Joining Wire Harness and Wire Harness

Code	See Page	Joining Wire Harness and Wire Harness (Connector Location)
BE1	51	Engine Wire and Instrument Panel Wire (Upper the Glove Box)
BE2		
EA2	51	Instrument Panel Wire and Engine Room Main Wire (Left Kick Panel)
EA4		
EE1	51	Instrument Panel Wire and Instrument Panel Wire (Instrument Panel RH)
EL1	51	Instrument Panel Wire and Floor No.2 Wire (Left Kick Panel)
LA2	51	Floor No.2 Wire and Engine Room Main Wire (Left Kick Panel)
OD1	52	Frame Wire and Differential Wire (No.6 Crossmember)
OL1	52	Frame Wire and Floor No.2 Wire (Under the Rear Seat)

: Ground Points

Code	See Page	Ground Points Location
B3	50	Rear Side of Left Bank Cylinder Block
E4	51	Left Kick Panel
L1	52	Floor Seat Crossmember LH
L2	52	Left Quarter Panel

NOTICE: When inspecting or repairing the SRS, perform service in accordance with the following precautionary instructions and the procedure, and precautions in the Repair Manual applicable for the model year.

- Malfunction symptoms of the SRS are difficult to confirm, so the DTCs become the most important source of information when troubleshooting. When troubleshooting the SRS, always inspect the DTCs before disconnecting the battery.
- **Work must be started more than 90 seconds after the ignition SW is turned to the "LOCK" position and the negative (-) terminal cable is disconnected from the battery.**
(The SRS is equipped with a back-up power source so that if work is started within 90 seconds from disconnecting the negative (-) terminal cable of the battery, the SRS may deploy.)
- When the negative (-) terminal cable is disconnected from the battery, the memory of the clock and audio system will be cleared. So before starting work, make a record of the contents in the audio memory system. When work is finished, reset the audio systems as they were before and adjust the clock. Some vehicles have power tilt steering, power telescopic steering, power seat and power outside rear view mirror which are all equipped with memory function. However, it is not possible to make a record of these memory contents. So when the work is finished, it will be necessary to explain it to your customer, and ask the customer to adjust the features and reset the memory. To avoid erasing the memory in each system, never use a back-up power supply from outside the vehicle.
- Before repair, remove the airbag sensor if shocks are likely to be applied to the sensor during repair.
- Do not expose the following parts directly to hot air or flame;
- Even in cases of a minor collision where the SRS does not deploy, the following parts should be inspected;
- Never use SRS parts from another vehicle. When replacing parts, replace with new parts.
- For the purpose of reuse, never disassemble and repair the following parts.
- If the following parts have been dropped, or have cracks, dents and other defects in their case, bracket, and connector, replace with new one.
- Use a volt/ohmmeter with high impedance (10 k Ω /V minimum) for troubleshooting electrical circuits of the system.
- Information labels are attached to the periphery of the SRS components. Follow the instructions of the notice.
- After work on the SRS is completed, check the SRS warning light.
- If the vehicle is equipped with a mobile communication system, refer to the precaution in the IN section of the Repair Manual.

- * Steering wheel pad
- * Front passenger airbag assembly
- * Side airbag assembly
- * Curtain shield airbag assembly
- * Seat belt pretensioner
- * Center airbag sensor assembly
- * Front airbag sensor assembly
- * Side airbag sensor assembly
- * Rear airbag sensor assembly

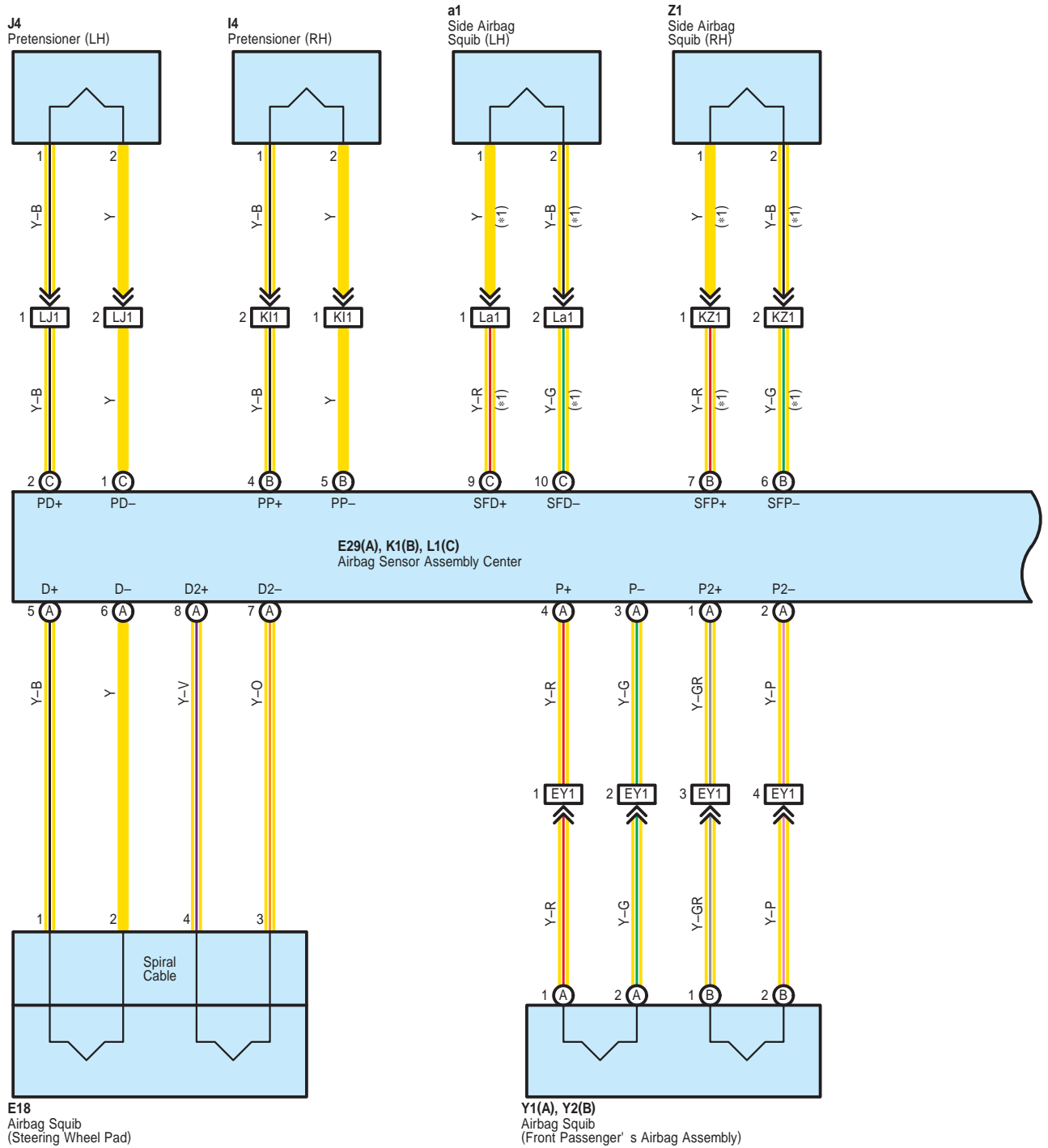

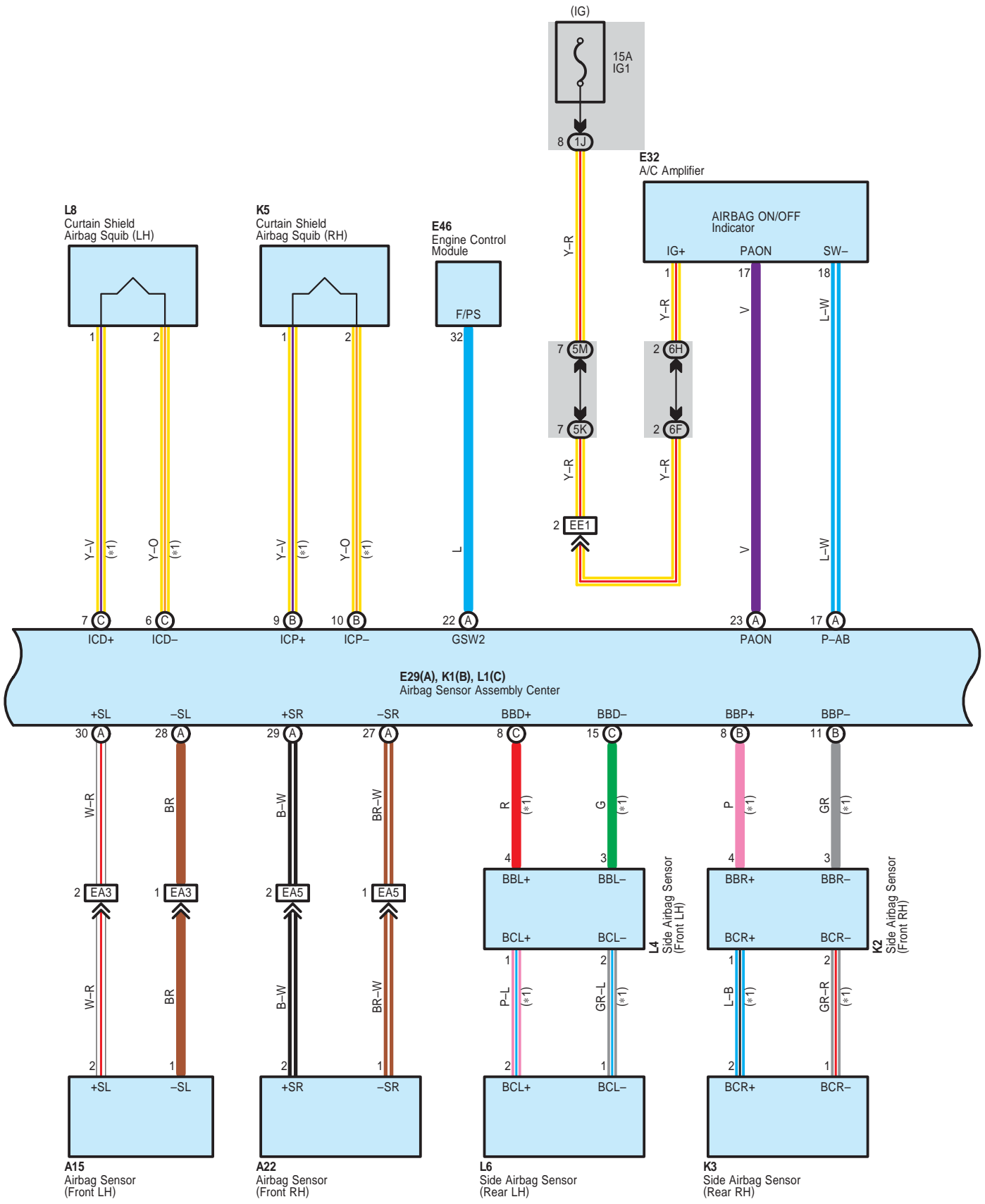

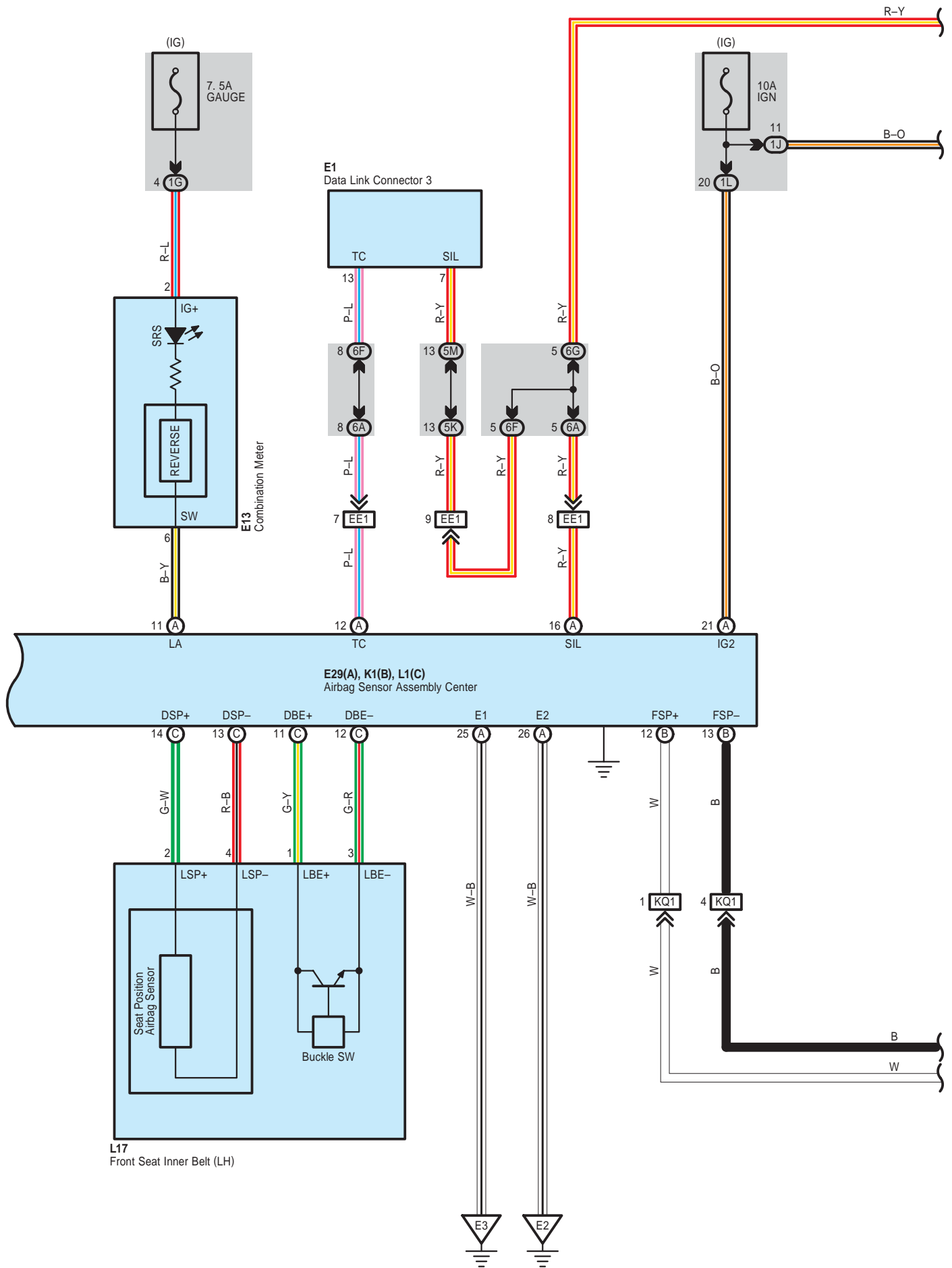

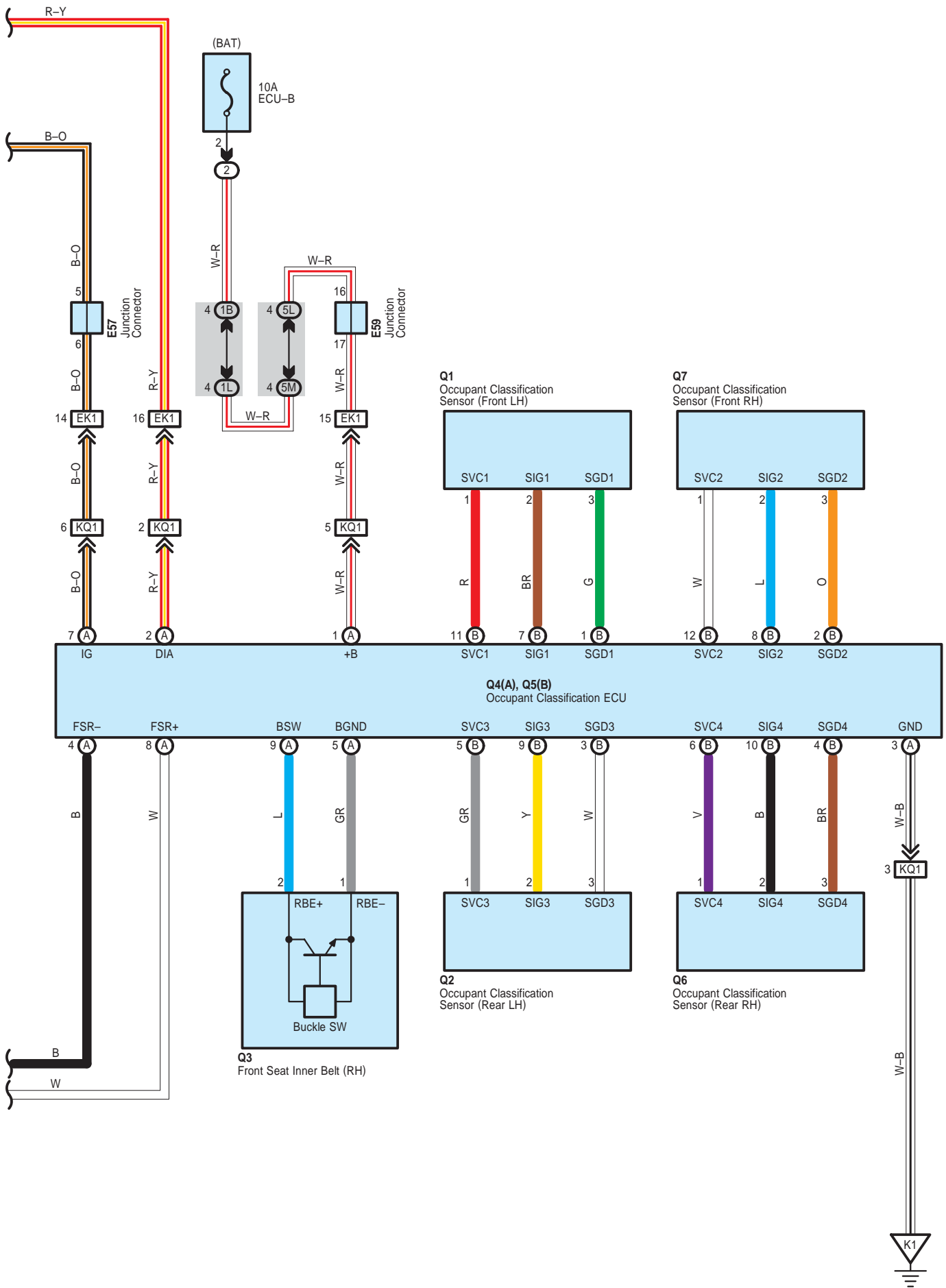

System Outline

- * The system reaches an ignition judgment to deploy the following device based on the signals received from the front airbag sensor and deceleration sensor.
 - Driver Airbag
 - Front Passenger Airbag
 - Seat Belt Pretensioner
- * The system reaches an ignition judgment to deploy the following device based on the signals received from the side airbag sensors.
 - Side Airbags
 - Curtain Shield Airbags
- * The dual-stage SRS airbag system has been used for the driver and front passenger airbags. This system controls the optimal airbag inflation by judging the extent of impact, seat position (driver seat) and whether or not the seat belt is fastened(driver seat) and information from the Front Passenger Occupant Classification System.
- * The front passenger occupant classification system judges whether the front passenger seat is occupied by an adult or child (with child seat) or is unoccupied, according to the load applied to the front passenger seat and whether the seat belt is buckled. Based on the results, it restricts the deployment of the front passenger airbag, front passenger side airbag, and front passenger seat belt pretensioner. In addition, the system informs the driver of the result of the judgment through the use of the AIRBAG ON/OFF indicator lights.
- * The airbag sensor assembly transmits a signal to the Engine Control Module in order to stop the fuel pump.

○ : Parts Location

Code	See Page	Code	See Page	Code	See Page
A15	38	J4	47	Q2	48
A22	38	K1 B	45	Q3	48
E1	42	K2	46	Q4 A	48
E13	42	K3	46	Q5 B	48
E18	42	K5	46	Q6	48
E29 A	43	L1 C	45	Q7	48
E32	43	L4	46	Y1 A	45
E46	43	L6	46	Y2 B	45
E57	44	L8	46	Z1	48
E59	44	L17	48	a1	48
I4	47	Q1	48		

○ : Relay Blocks

Code	See Page	Relay Blocks (Relay Block Location)
2	22	Engine Room R/B No.2 (Engine Compartment Left)

○ : Junction Block and Wire Harness Connector

Code	See Page	Junction Block and Wire Harness (Connector Location)
1B	24	Engine Room Main Wire and Driver Side J/B (Lower Finish Panel)
1G	25	Instrument Panel Wire and Driver Side J/B (Lower Finish Panel)
1J		
1L		
5K	28	Instrument Panel Wire and Center J/B LH (Instrument Panel LH)
5L		
5M		
6A	32	Instrument Panel Wire and Center J/B RH (Instrument Panel RH)
6F		
6G		
6H		

 : Connector Joining Wire Harness and Wire Harness

Code	See Page	Joining Wire Harness and Wire Harness (Connector Location)
EA3	51	Instrument Panel Wire and Engine Room Main Wire (Left Kick Panel)
EA5	51	Instrument Panel Wire and Engine Room Main Wire (Right Kick Panel)
EE1	51	Instrument Panel Wire and Instrument Panel Wire (Instrument Panel RH)
EK1	51	Instrument Panel Wire and Floor Wire (Right Kick Panel)
EY1	51	Instrument Panel Wire and Instrument Panel Wire Assembly (Upper the Glove Box)
KI1	52	Floor Wire and Rear Door No.1 Wire (Right Quarter Panel)
KQ1	53	Floor Wire and Seat No.1 Wire (Under the Front Seat RH)
KZ1	53	Floor Wire and Seat Airbag RH Wire (Under the Front Seat RH)
LJ1	52	Floor No.2 Wire and Rear Door No.2 Wire (Left Quarter Panel)
La1	53	Floor No.2 Wire and Seat Airbag LH Wire (Under the Front Seat LH)

 : Ground Points

Code	See Page	Ground Points Location
E2	51	Instrument Panel Brace LH
E3	51	Instrument Panel Brace RH
K1	52	Floor Seat Crossmember RH

Shift Lock

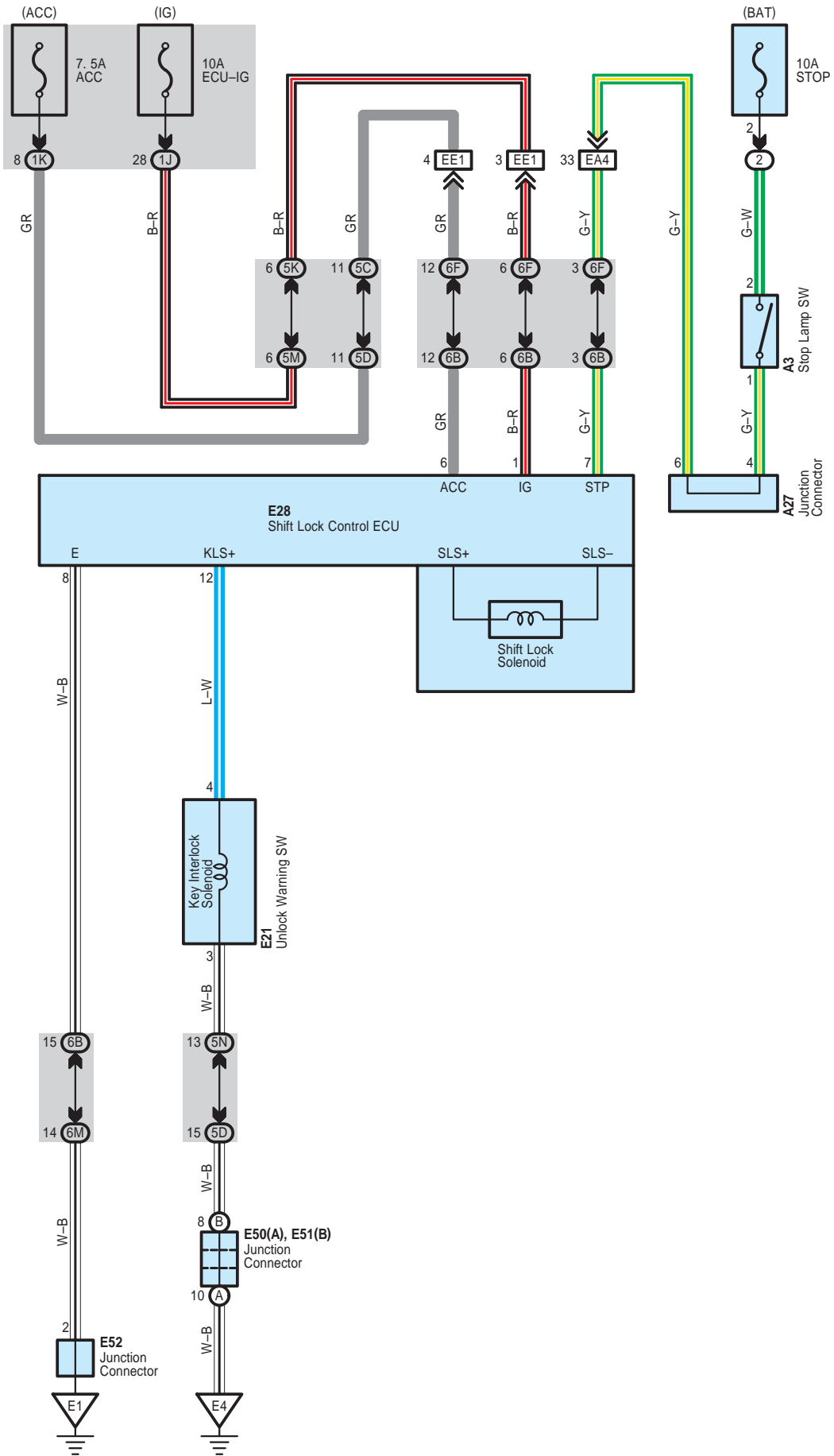

System Outline

When the ignition SW is turned to ACC position the current from the ACC fuse flows to TERMINAL 6 of the shift lock control ECU. When the ignition SW is turned to ON position, the current from the ECU-IG fuse flows to TERMINAL 1 of the shift lock control ECU.

1. Shift Lock Mechanism

If the brake pedal is depressed with the ignition SW set at ON (The stop lamp SW is on), the shift lock control ECU is activated, allowing the driver to change the shift lever to a position other than the P position.

2. Key Interlock Mechanism

With the ignition SW at ON or ACC position, when the shift lever is put in P position, the current flowing from TERMINAL 12 of the shift lock control ECU to key interlock solenoid is cut off. This causes the key interlock solenoid to turn off (Lock lever disengages from LOCK position) and the ignition key can be turned from ACC to LOCK position.

○ : Parts Location

Code	See Page	Code	See Page	Code	See Page
A3	45	E28	43	E52	44
A27	45	E50	A	44	
E21	42	E51	B	44	

○ : Relay Blocks

Code	See Page	Relay Blocks (Relay Block Location)
2	22	Engine Room R/B No.2 (Engine Compartment Left)

○ : Junction Block and Wire Harness Connector

Code	See Page	Junction Block and Wire Harness (Connector Location)
1J	25	Instrument Panel Wire and Driver Side J/B (Lower Finish Panel)
1K		
5C	28	Instrument Panel Wire and Center J/B LH (Instrument Panel LH)
5D		
5K		
5M		
5N		
6B	32	Instrument Panel Wire and Center J/B RH (Instrument Panel RH)
6F		
6M		

□ : Connector Joining Wire Harness and Wire Harness

Code	See Page	Joining Wire Harness and Wire Harness (Connector Location)
EA4	51	Instrument Panel Wire and Engine Room Main Wire (Left Kick Panel)
EE1	51	Instrument Panel Wire and Instrument Panel Wire (Instrument Panel RH)

▽ : Ground Points

Code	See Page	Ground Points Location
E1	51	Instrument Panel Brace RH
E4	51	Left Kick Panel

Remote Control Mirror

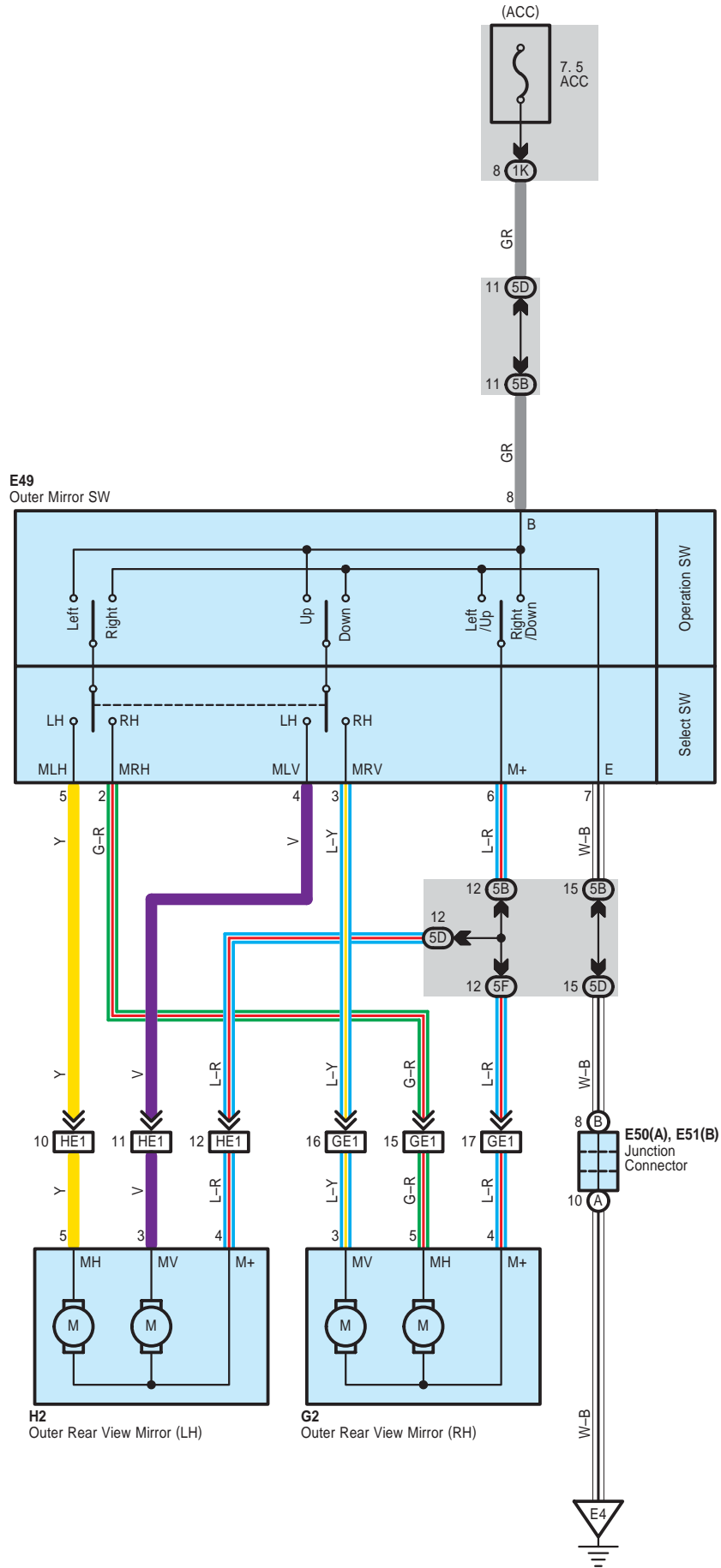

 : **Parts Location**

Code	See Page	Code	See Page	Code	See Page
E49	43	E51	B	44	H2
E50	A	44	G2	47	

 : **Junction Block and Wire Harness Connector**

Code	See Page	Junction Block and Wire Harness (Connector Location)
1K	25	Instrument Panel Wire and Driver Side J/B (Lower Finish Panel)
5B	28	Instrument Panel Wire and Center J/B LH (Instrument Panel LH)
5D		
5F		

 : **Connector Joining Wire Harness and Wire Harness**

Code	See Page	Joining Wire Harness and Wire Harness (Connector Location)
GE1	51	Front Door RH Wire and Instrument Panel Wire (Right Kick Panel)
HE1	51	Front Door LH Wire and Instrument Panel Wire (Left Kick Panel)

 : **Ground Points**

Code	See Page	Ground Points Location
E4	51	Left Kick Panel

Power Outlet for 115V

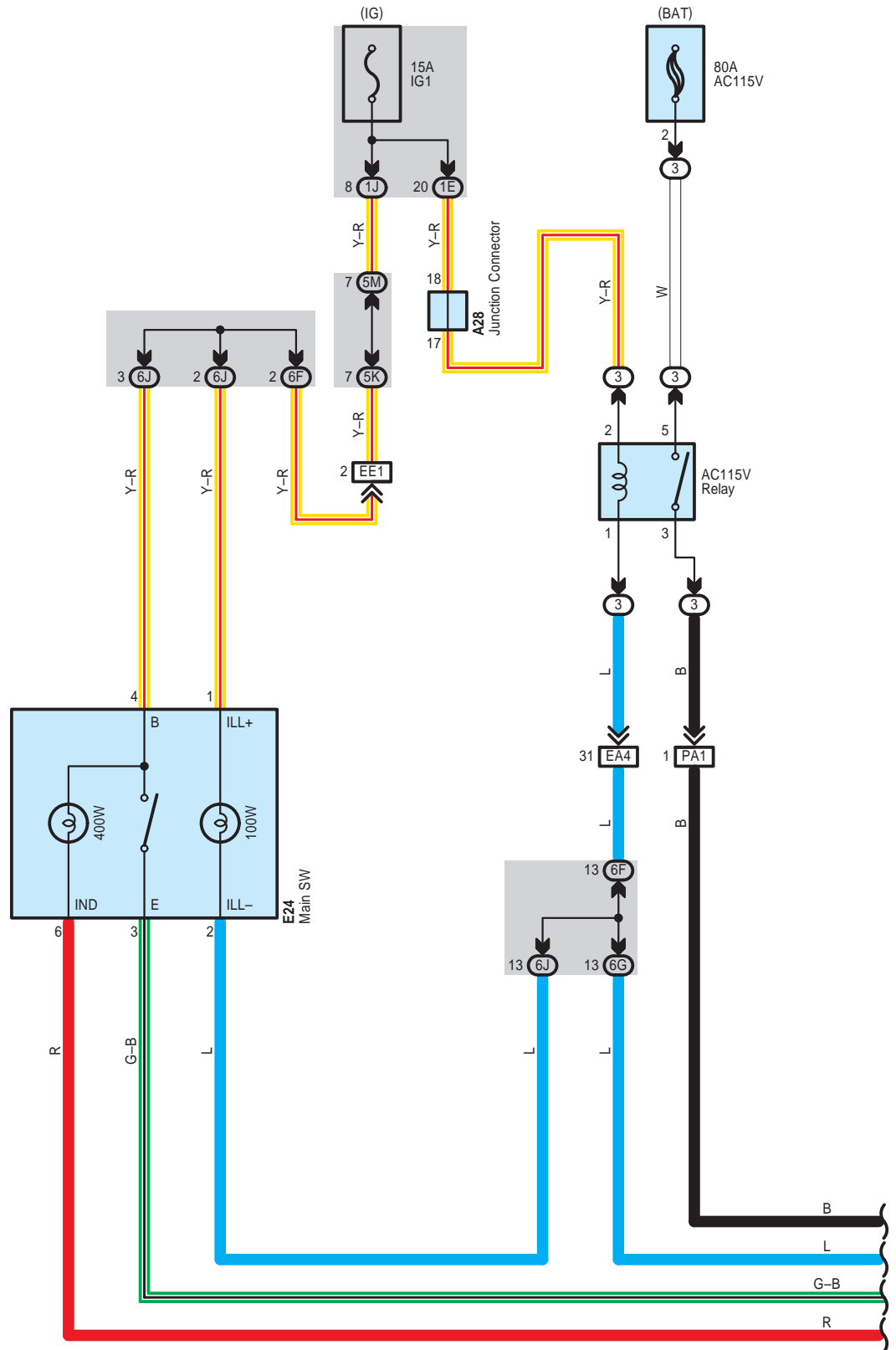

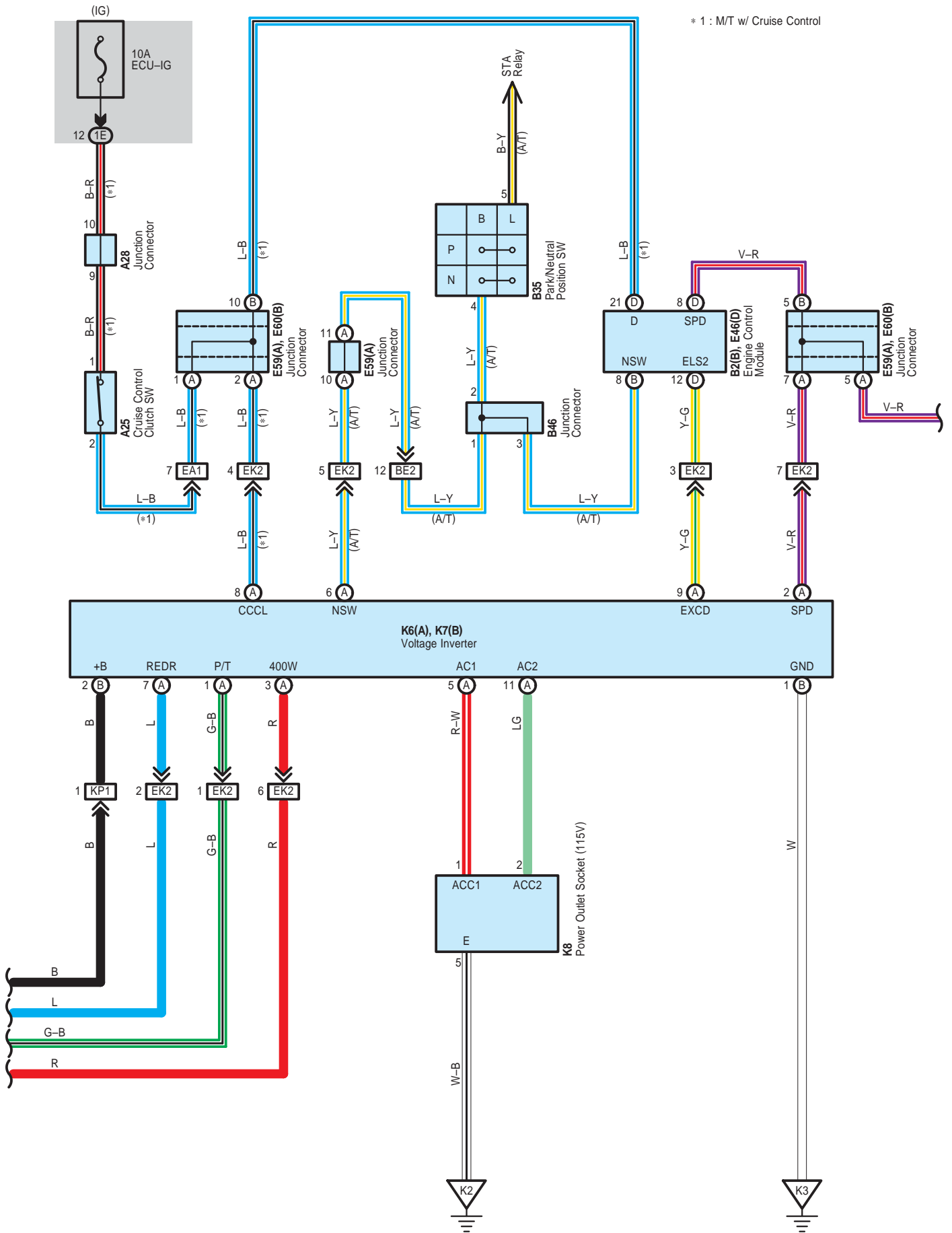

Power Outlet for 115V

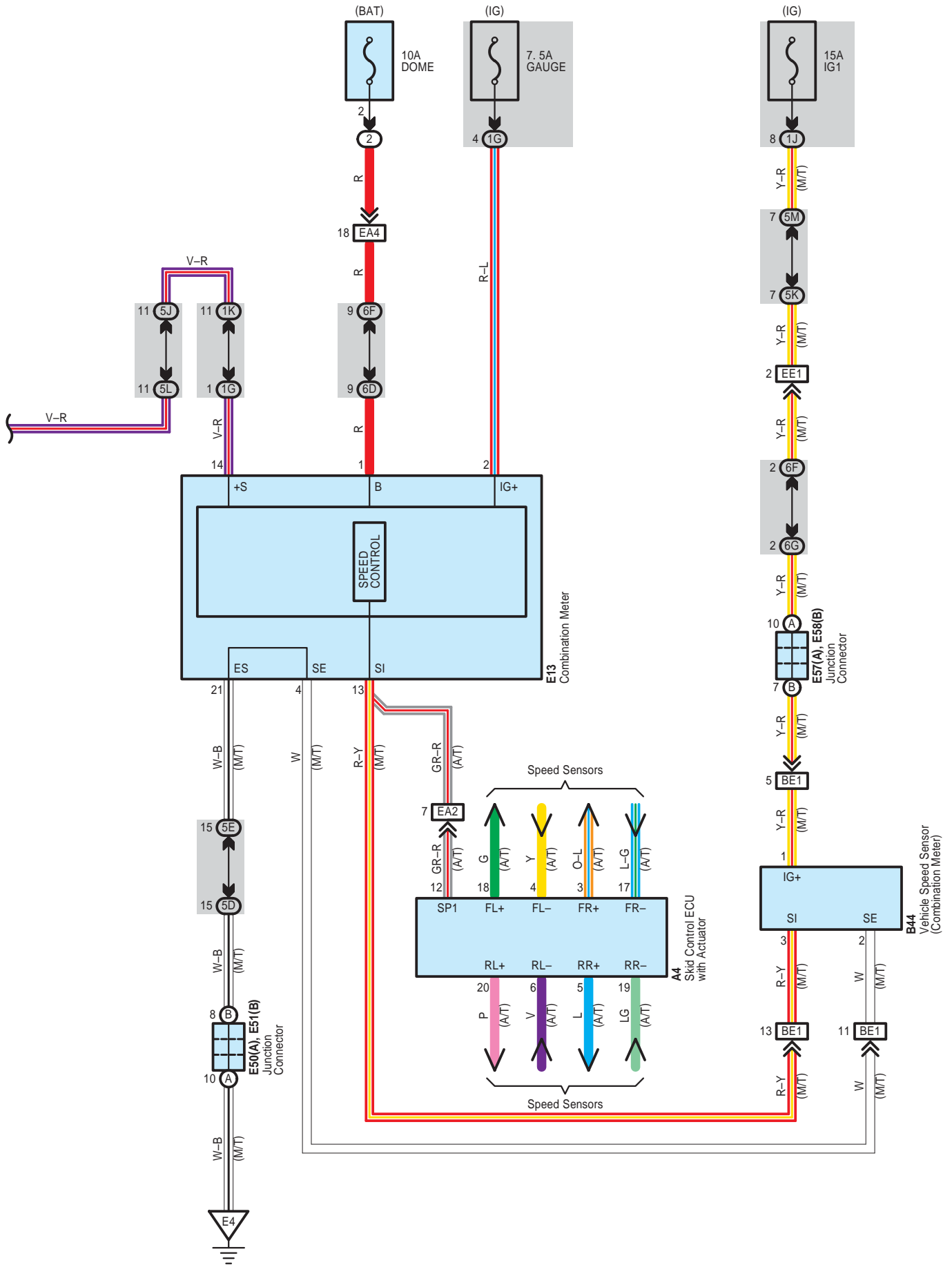

 : Parts Location

Code	See Page	Code	See Page	Code	See Page
A4	38	E13	42	E59	A 44
A25	45	E24	42	E60	B 44
A28	38	E46	D 43	K6	A 46
B2	B 45	E50	A 44	K7	B 46
B35	40	E51	B 44	K8	46
B44	40	E57	A 44		
B46	45	E58	B 44		

 : Relay Blocks

Code	See Page	Relay Blocks (Relay Block Location)
2	22	Engine Room R/B No.2 (Engine Compartment Left)
3	23	Engine Room R/B No.3 (Engine Compartment Left)

 : Junction Block and Wire Harness Connector

Code	See Page	Junction Block and Wire Harness (Connector Location)
1E	24	Engine Room Main Wire and Driver Side J/B (Lower Finish Panel)
1G	25	Instrument Panel Wire and Driver Side J/B (Lower Finish Panel)
1J		
1K		
5D	28	Instrument Panel Wire and Center J/B LH (Instrument Panel LH)
5E		
5J		
5K		
5L		
5M		
6D	32	Instrument Panel Wire and Center J/B RH (Instrument Panel RH)
6F		
6G		
6J		

 : Connector Joining Wire Harness and Wire Harness

Code	See Page	Joining Wire Harness and Wire Harness (Connector Location)
BE1	51	Engine Wire and Instrument Panel Wire (Upper the Glove Box)
BE2		
EA1	51	Instrument Panel Wire and Engine Room Main Wire (Left Kick Panel)
EA2		
EA4		
EE1	51	Instrument Panel Wire and Instrument Panel Wire (Instrument Panel RH)
EK2	51	Instrument Panel Wire and Floor Wire (Right Kick Panel)
KP1	52	Floor Wire and Frame No.2 Wire (Rear Side of Side Frame RH)
PA1	50	Frame No.2 Wire and Engine Room Main Wire (Right Dash Panel)

 : Ground Points

Code	See Page	Ground Points Location
E4	51	Left Kick Panel
K2	52	Rear Wheel House RH
K3		

Power Outlet for 12V

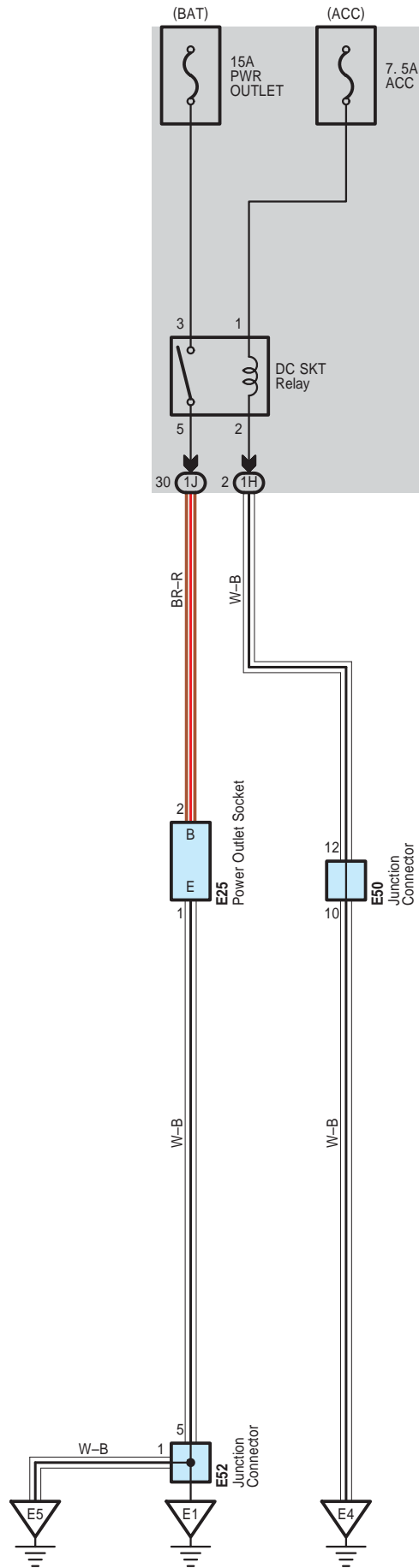

 : **Parts Location**

Code	See Page	Code	See Page	Code	See Page
E25	42	E50	44	E52	44

 : **Junction Block and Wire Harness Connector**

Code	See Page	Junction Block and Wire Harness (Connector Location)
1H	25	Instrument Panel Wire and Driver Side J/B (Lower Finish Panel)
1J		

 : **Ground Points**

Code	See Page	Ground Points Location
E1	51	Instrument Panel Brace RH
E4	51	Left Kick Panel
E5	51	Right Kick Panel

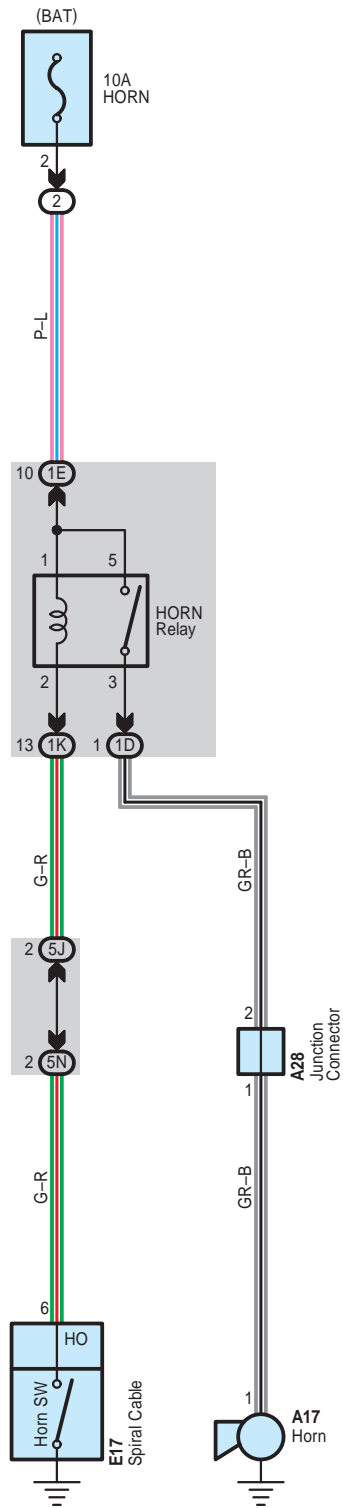

○ : Parts Location

Code	See Page	Code	See Page	Code	See Page
A17	38	A28	38	E17	42

○ : Relay Blocks

Code	See Page	Relay Blocks (Relay Block Location)
2	22	Engine Room R/B No.2 (Engine Compartment Left)

○ : Junction Block and Wire Harness Connector

Code	See Page	Junction Block and Wire Harness (Connector Location)
1D	24	Engine Room Main Wire and Driver Side J/B (Lower Finish Panel)
1E		
1K	25	Instrument Panel Wire and Driver Side J/B (Lower Finish Panel)
5J	28	Instrument Panel Wire and Center J/B LH (Instrument Panel LH)
5N		

Electric Tension Reducer

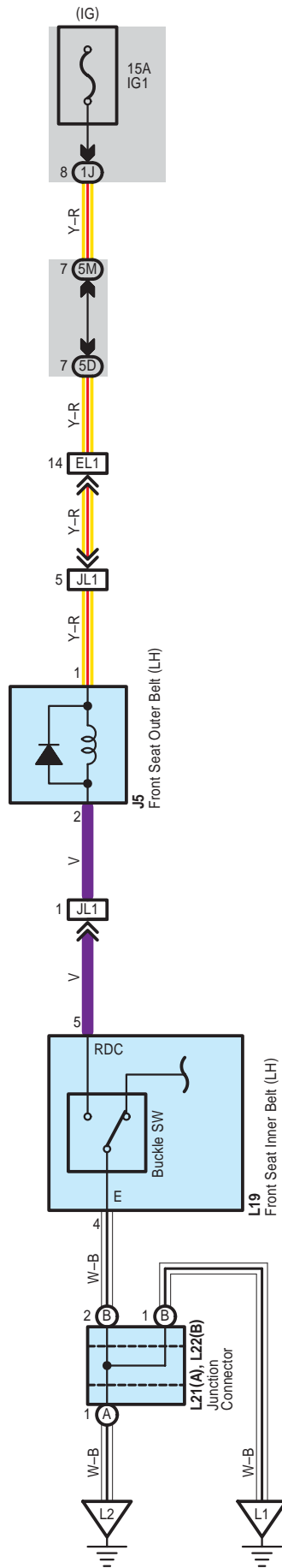

 : **Parts Location**

Code	See Page	Code	See Page	Code	See Page
J5	47	L21	A	46	
L19	48	L22	B	46	

 : **Junction Block and Wire Harness Connector**

Code	See Page	Junction Block and Wire Harness (Connector Location)
1J	25	Instrument Panel Wire and Driver Side J/B (Lower Finish Panel)
5D	28	Instrument Panel Wire and Center J/B LH (Instrument Panel LH)
5M		

 : **Connector Joining Wire Harness and Wire Harness**

Code	See Page	Joining Wire Harness and Wire Harness (Connector Location)
EL1	51	Instrument Panel Wire and Floor No.2 Wire (Left Kick Panel)
JL1	52	Rear Door No.2 Wire and Floor No.2 Wire (Left Quarter Panel)

 : **Ground Points**

Code	See Page	Ground Points Location
L1	52	Floor Seat Crossmember LH
L2	52	Left Quarter Panel

Rear Window Defogger

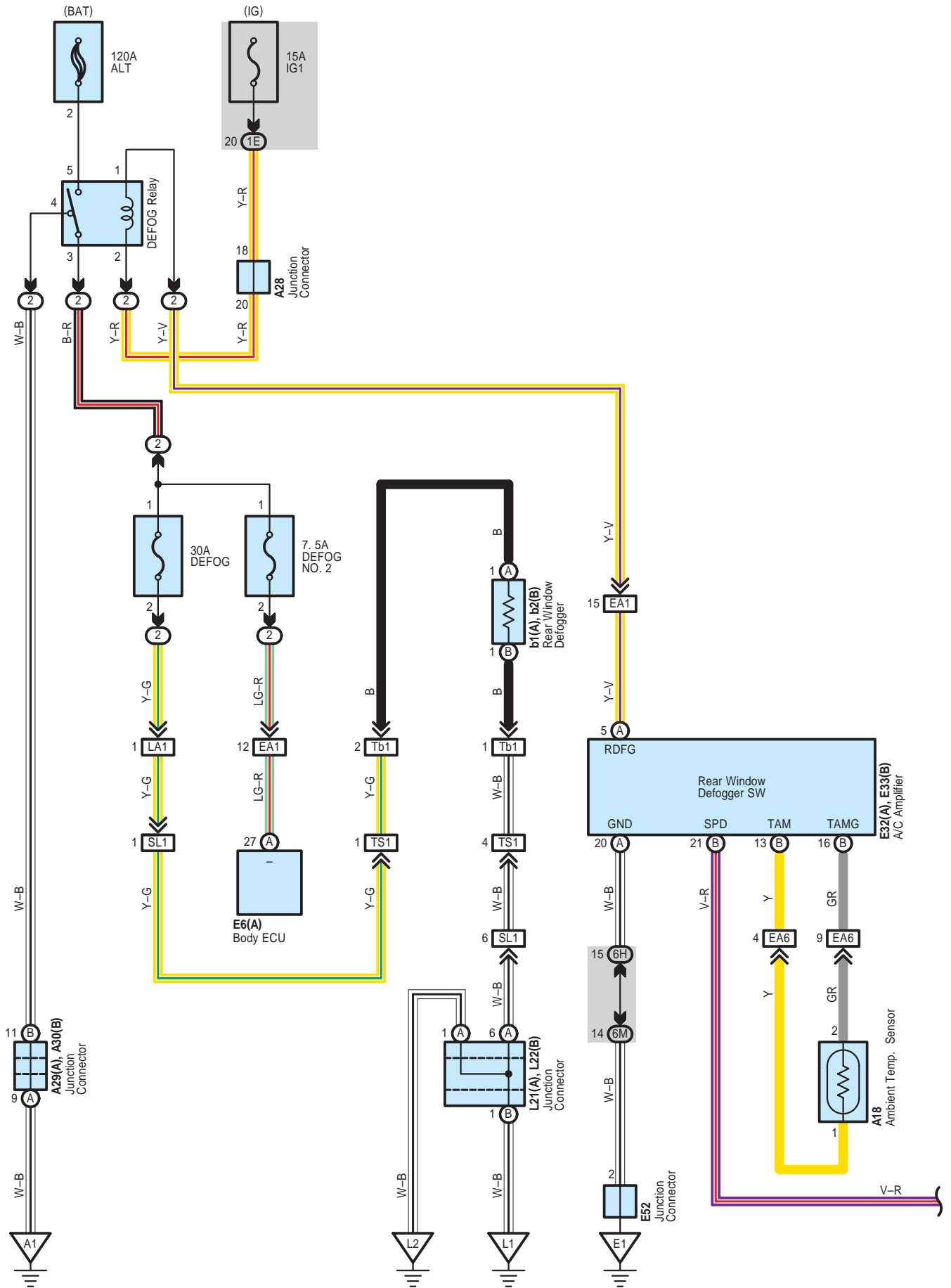

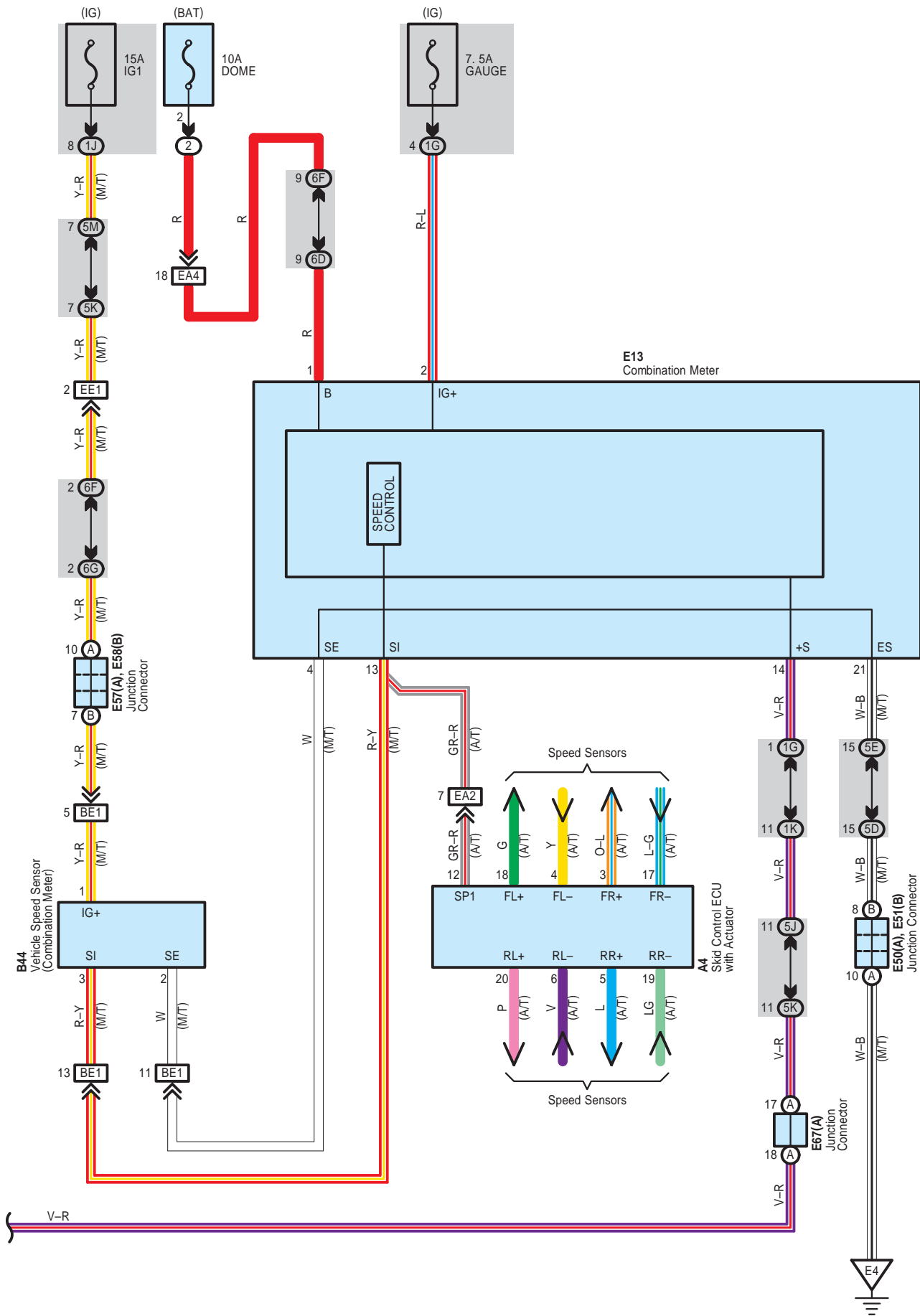

Rear Window Defogger

○ : Parts Location

Code	See Page	Code	See Page	Code	See Page
A4	38	E13	42	E58	B 44
A18	38	E32	A 43	E67	A 44
A28	38	E33	B 43	L21	A 46
A29	A 38	E50	A 44	L22	B 46
A30	B 38	E51	B 44	b1	A 47
B44	40	E52	44	b2	B 47
E6	A 42	E57	A 44		

○ : Relay Blocks

Code	See Page	Relay Blocks (Relay Block Location)
2	22	Engine Room R/B No.2 (Engine Compartment Left)

○ : Junction Block and Wire Harness Connector

Code	See Page	Junction Block and Wire Harness (Connector Location)
1E	24	Engine Room Main Wire and Driver Side J/B (Lower Finish Panel)
1G	25	Instrument Panel Wire and Driver Side J/B (Lower Finish Panel)
1J		
1K		
5D	28	Instrument Panel Wire and Center J/B LH (Instrument Panel LH)
5E		
5J		
5K		
5M	32	Instrument Panel Wire and Center J/B RH (Instrument Panel RH)
6D		
6F		
6G		
6H		
6M		

□ : Connector Joining Wire Harness and Wire Harness

Code	See Page	Joining Wire Harness and Wire Harness (Connector Location)
BE1	51	Engine Wire and Instrument Panel Wire (Upper the Glove Box)
EA1	51	Instrument Panel Wire and Engine Room Main Wire (Left Kick Panel)
EA2		
EA4		
EA6	51	Instrument Panel Wire and Engine Room Main Wire (Right Kick Panel)
EE1	51	Instrument Panel Wire and Instrument Panel Wire (Instrument Panel RH)
LA1	51	Floor No.2 Wire and Engine Room Main Wire (Left Kick Panel)
SL1	52	Back Door No.1 Wire and Floor No.2 Wire (Left Quarter Panel)
TS1	52	Back Door No.2 Wire and Back Door No.1 Wire (Left Side of Back Door)
Tb1	52	Back Door No.2 Wire and Rear Window No.1 Wire (Upper Side of Back Door)

▽ : Ground Points

Code	See Page	Ground Points Location
A1	50	Left Fender Apron
E1	51	Instrument Panel Brace RH
E4	51	Left Kick Panel
L1	52	Floor Seat Crossmember LH
L2	52	Left Quarter Panel

Clock

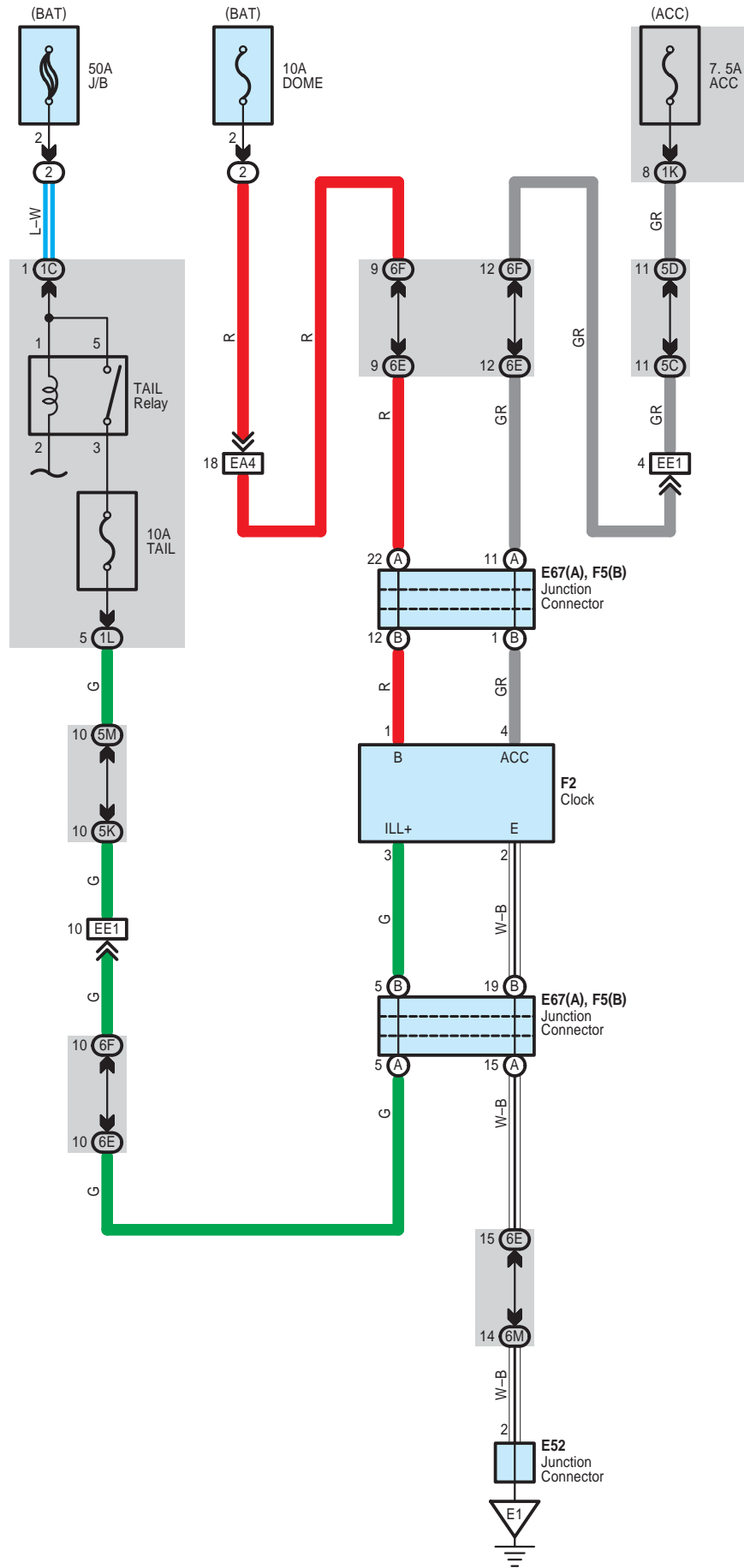

 : **Parts Location**

Code	See Page	Code	See Page	Code	See Page
E52	44	F2	45		
E67	A 44	F5	B 45		

 : **Relay Blocks**

Code	See Page	Relay Blocks (Relay Block Location)
2	22	Engine Room R/B No.2 (Engine Compartment Left)

 : **Junction Block and Wire Harness Connector**

Code	See Page	Junction Block and Wire Harness (Connector Location)
1C	24	Engine Room Main Wire and Driver Side J/B (Lower Finish Panel)
1K	25	Instrument Panel Wire and Driver Side J/B (Lower Finish Panel)
1L		
5C	28	Instrument Panel Wire and Center J/B LH (Instrument Panel LH)
5D		
5K		
5M		
6E	32	Instrument Panel Wire and Center J/B RH (Instrument Panel RH)
6F		
6M		

 : **Connector Joining Wire Harness and Wire Harness**

Code	See Page	Joining Wire Harness and Wire Harness (Connector Location)
EA4	51	Instrument Panel Wire and Engine Room Main Wire (Left Kick Panel)
EE1	51	Instrument Panel Wire and Instrument Panel Wire (Instrument Panel RH)

 : **Ground Points**

Code	See Page	Ground Points Location
E1	51	Instrument Panel Brace RH

Accessory Meter

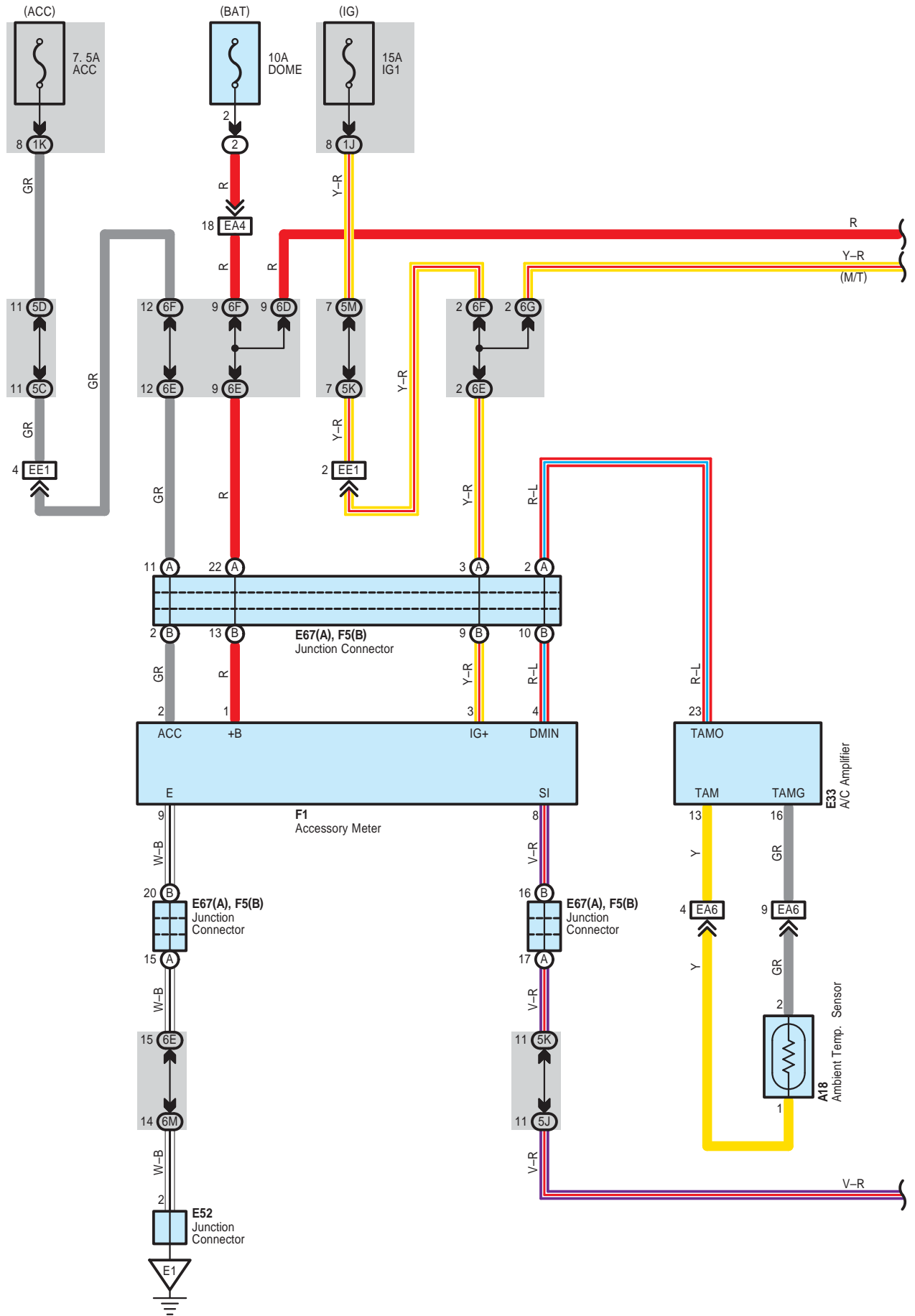

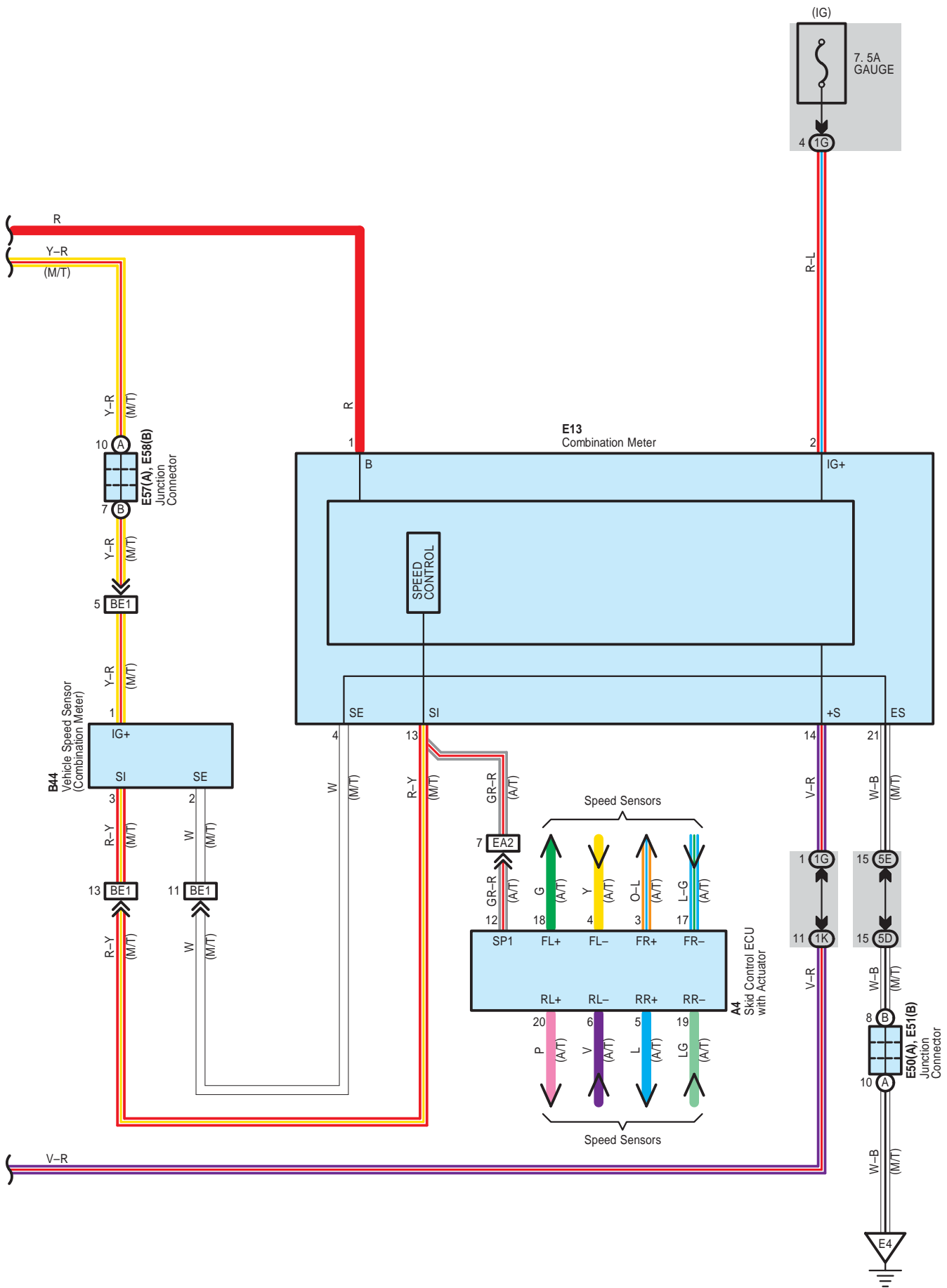

FJ CRUISER (EM0240U)

Accessory Meter

: Parts Location

Code	See Page	Code	See Page	Code	See Page
A4	38	E50	A 44	E67	A 44
A18	38	E51	B 44	F1	45
B44	40	E52	44	F5	B 45
E13	42	E57	A 44		
E33	43	E58	B 44		

: Relay Blocks

Code	See Page	Relay Blocks (Relay Block Location)
2	22	Engine Room R/B No.2 (Engine Compartment Left)

: Junction Block and Wire Harness Connector

Code	See Page	Junction Block and Wire Harness (Connector Location)
1G	25	Instrument Panel Wire and Driver Side J/B (Lower Finish Panel)
1J		
1K		
5C	28	Instrument Panel Wire and Center J/B LH (Instrument Panel LH)
5D		
5E		
5J		
5K		
5M		
6D	32	Instrument Panel Wire and Center J/B RH (Instrument Panel RH)
6E		
6F		
6G		
6M		

: Connector Joining Wire Harness and Wire Harness

Code	See Page	Joining Wire Harness and Wire Harness (Connector Location)
BE1	51	Engine Wire and Instrument Panel Wire (Upper the Glove Box)
EA2	51	Instrument Panel Wire and Engine Room Main Wire (Left Kick Panel)
EA4		
EA6	51	Instrument Panel Wire and Engine Room Main Wire (Right Kick Panel)
EE1	51	Instrument Panel Wire and Instrument Panel Wire (Instrument Panel RH)

: Ground Points

Code	See Page	Ground Points Location
E1	51	Instrument Panel Brace RH
E4	51	Left Kick Panel

Parking Assist (Clearance Sonar)

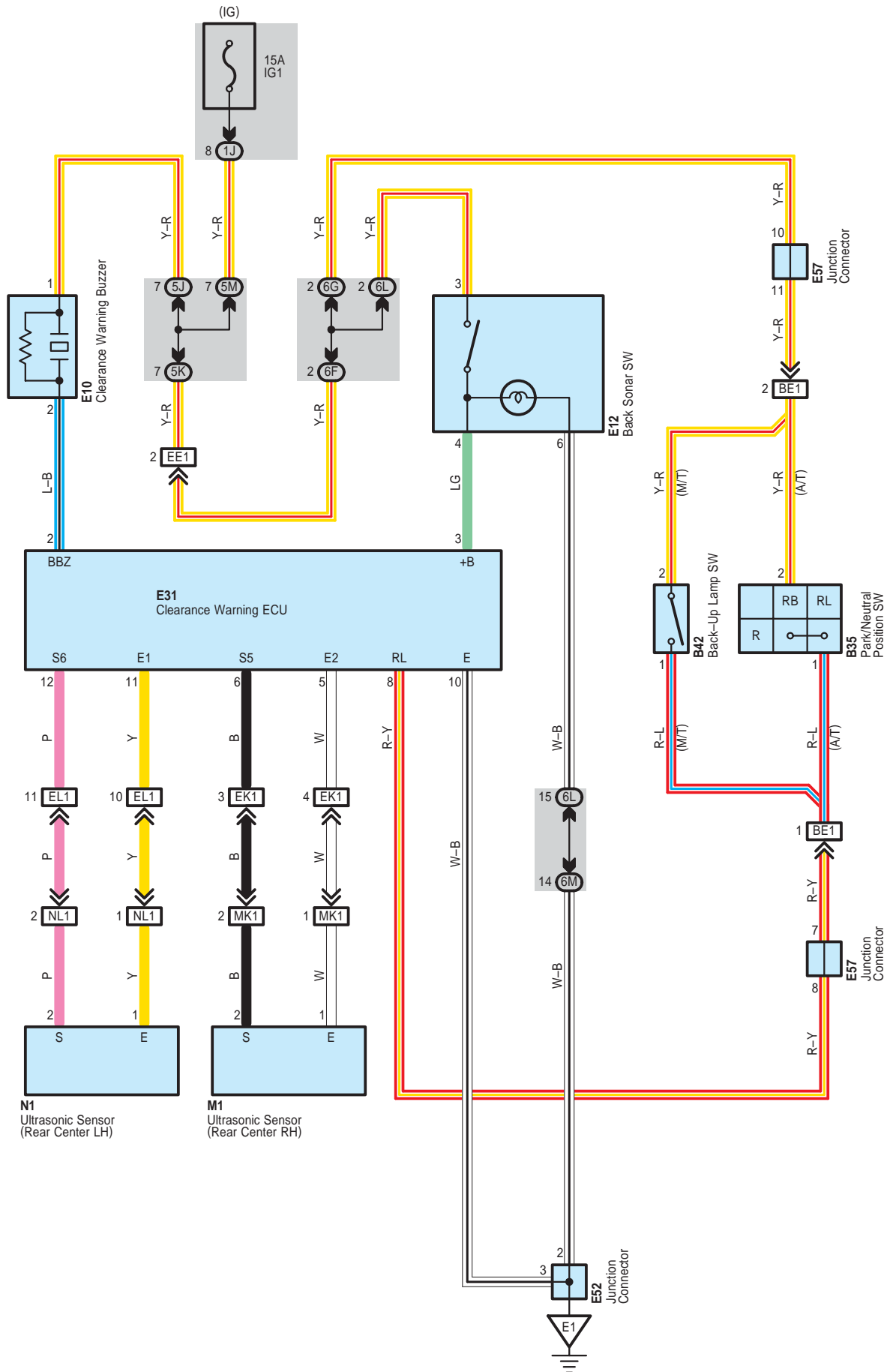

System Outline

The back sonar is a system which detects objects behind the vehicle by using ultra sonic sensor and informs the driver the distance between the sensor and objects with buzzer.

○ : Parts Location

Code	See Page	Code	See Page	Code	See Page
B35	40	E12	42	E57	44
B42	40	E31	43	M1	47
E10	42	E52	44	N1	47

○ : Junction Block and Wire Harness Connector

Code	See Page	Junction Block and Wire Harness (Connector Location)
1J	25	Instrument Panel Wire and Driver Side J/B (Lower Finish Panel)
5J	28	Instrument Panel Wire and Center J/B LH (Instrument Panel LH)
5K		
5M		
6F	32	Instrument Panel Wire and Center J/B RH (Instrument Panel RH)
6G		
6L		
6M		

□ : Connector Joining Wire Harness and Wire Harness

Code	See Page	Joining Wire Harness and Wire Harness (Connector Location)
BE1	51	Engine Wire and Instrument Panel Wire (Upper the Glove Box)
EE1	51	Instrument Panel Wire and Instrument Panel Wire (Instrument Panel RH)
EK1	51	Instrument Panel Wire and Floor Wire (Right Kick Panel)
EL1	51	Instrument Panel Wire and Floor No.2 Wire (Left Kick Panel)
MK1	52	Floor No.3 RH Wire and Floor Wire (Rear Side of Side Frame RH)
NL1	52	Floor No.3 LH Wire and Floor No.2 Wire (Rear Side of Side Frame LH)

▽ : Ground Points

Code	See Page	Ground Points Location
E1	51	Instrument Panel Brace RH

Audio System

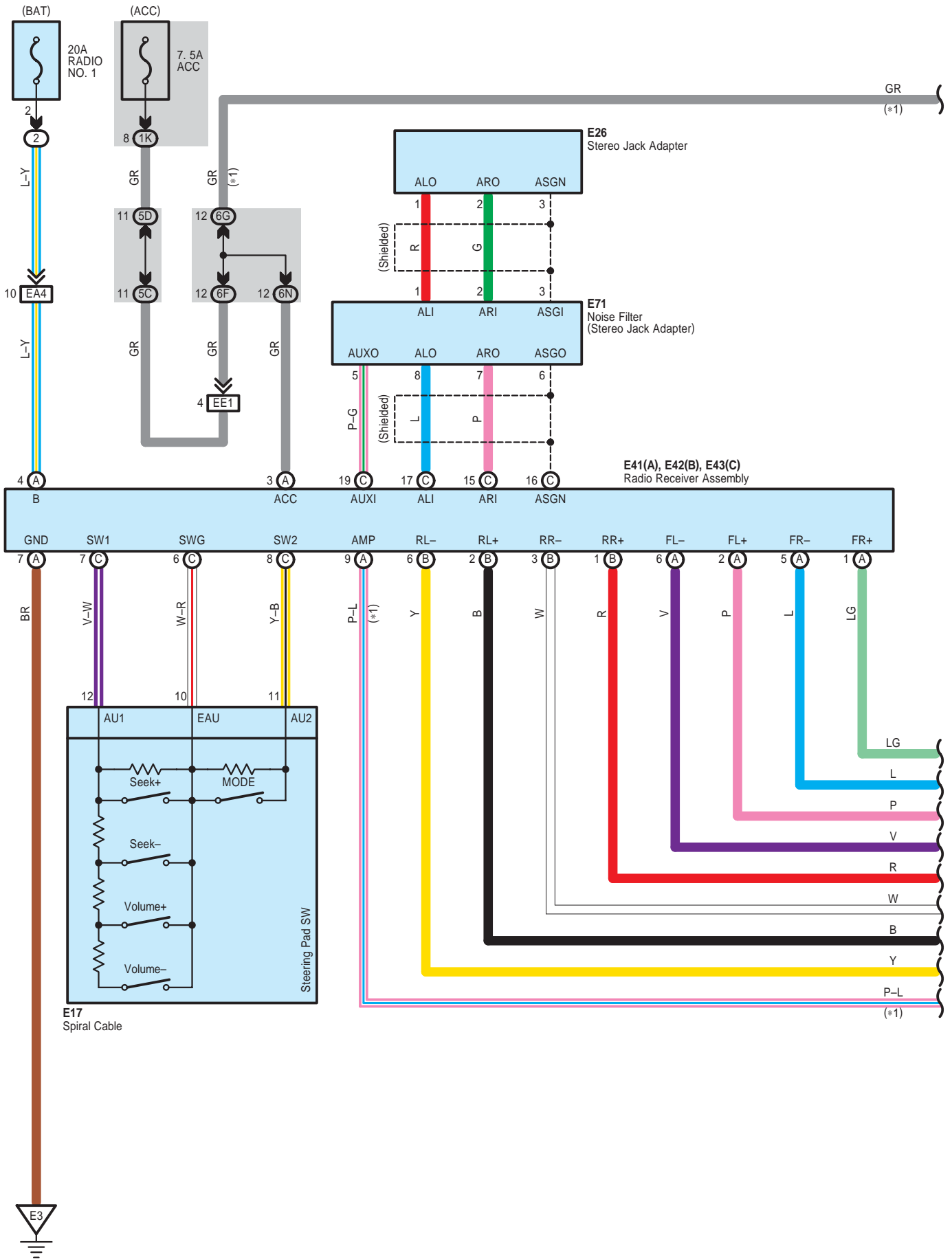

* 1 : w/ Woofer

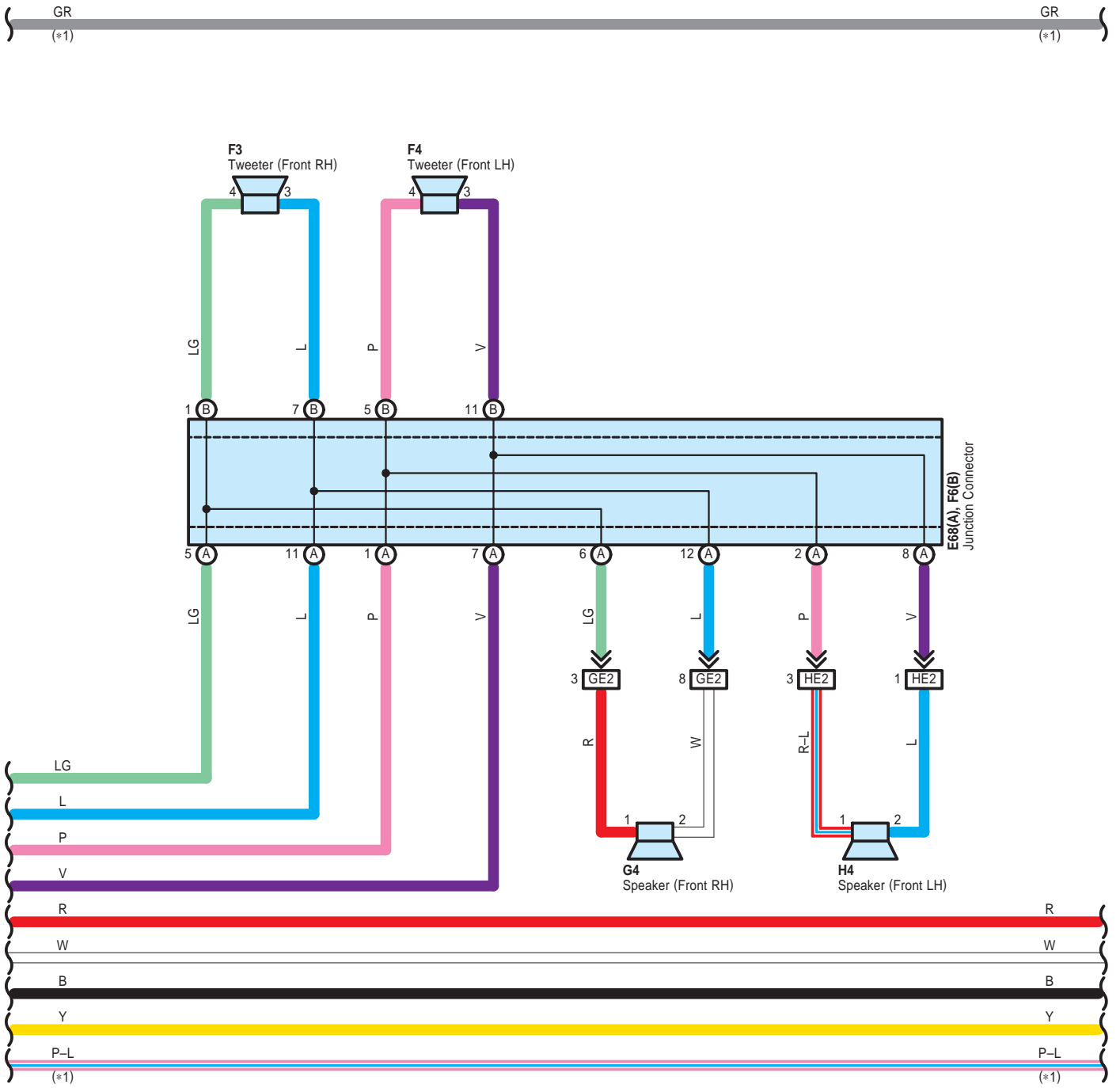

Audio System

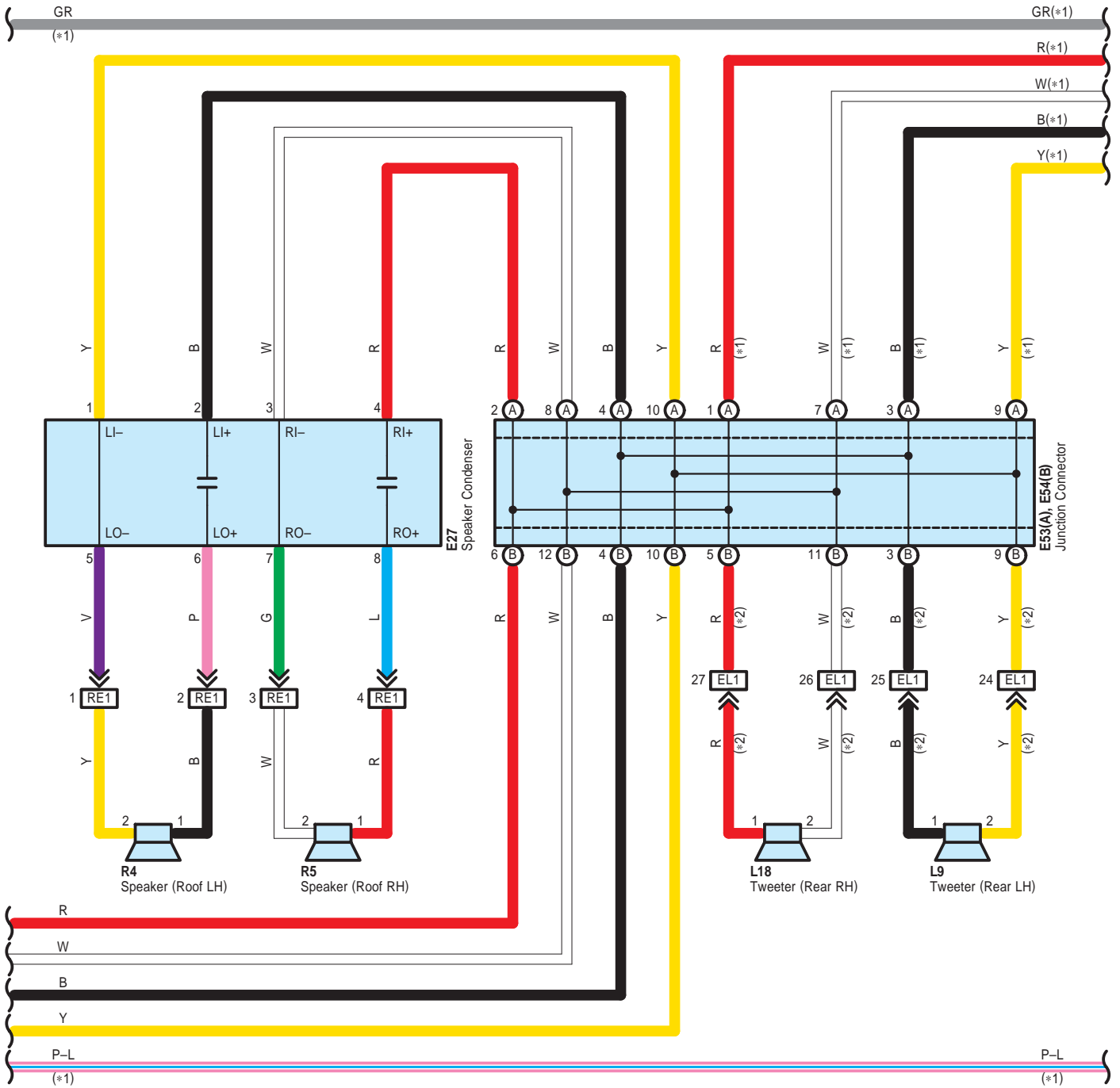

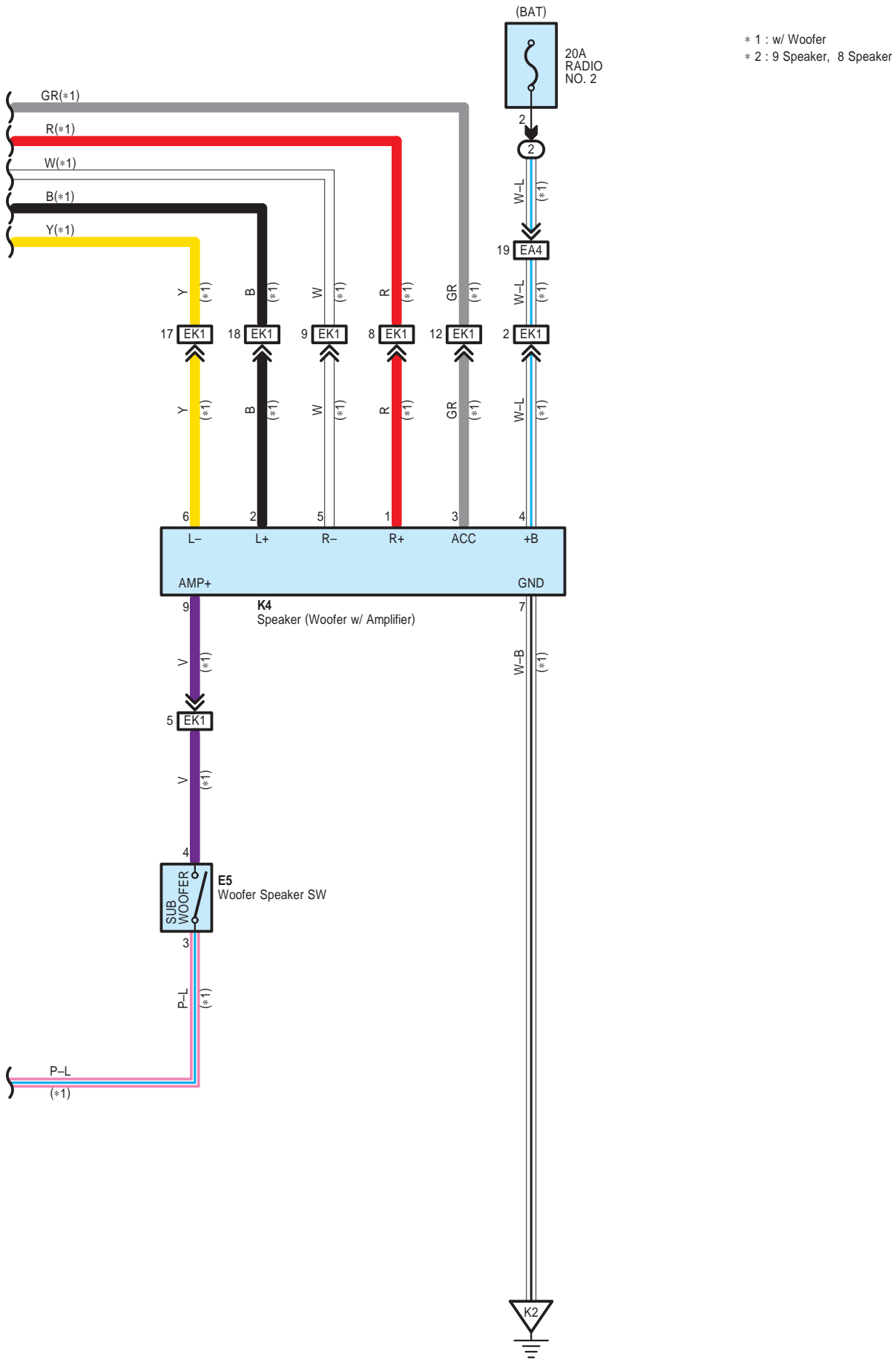

Audio System

: Parts Location

Code		See Page	Code		See Page	Code		See Page
E5		42	E53	A	44	G4		47
E17		42	E54	B	44	H4		47
E26		43	E68	A	44	K4		46
E27		43	E71		44	L9		46
E41	A	43	F3		45	L18		46
E42	B	43	F4		45	R4		47
E43	C	43	F6	B	45	R5		47

: Relay Blocks

Code	See Page	Relay Blocks (Relay Block Location)
2	22	Engine Room R/B No.2 (Engine Compartment Left)

: Junction Block and Wire Harness Connector

Code	See Page	Junction Block and Wire Harness (Connector Location)
1K	25	Instrument Panel Wire and Driver Side J/B (Lower Finish Panel)
5C	28	Instrument Panel Wire and Center J/B LH (Instrument Panel LH)
5D		
6F	32	Instrument Panel Wire and Center J/B RH (Instrument Panel RH)
6G		
6N		

: Connector Joining Wire Harness and Wire Harness

Code	See Page	Joining Wire Harness and Wire Harness (Connector Location)
EA4	51	Instrument Panel Wire and Engine Room Main Wire (Left Kick Panel)
EE1	51	Instrument Panel Wire and Instrument Panel Wire (Instrument Panel RH)
EK1	51	Instrument Panel Wire and Floor Wire (Right Kick Panel)
EL1	51	Instrument Panel Wire and Floor No.2 Wire (Left Kick Panel)
GE2	51	Front Door RH Wire and Instrument Panel Wire (Right Kick Panel)
HE2	51	Front Door LH Wire and Instrument Panel Wire (Left Kick Panel)
RE1	51	Roof Wire and Instrument Panel Wire (Left Kick Panel)

: Ground Points

Code	See Page	Ground Points Location
E3	51	Instrument Panel Brace RH
K2	52	Rear Wheel House RH

Combination Meter

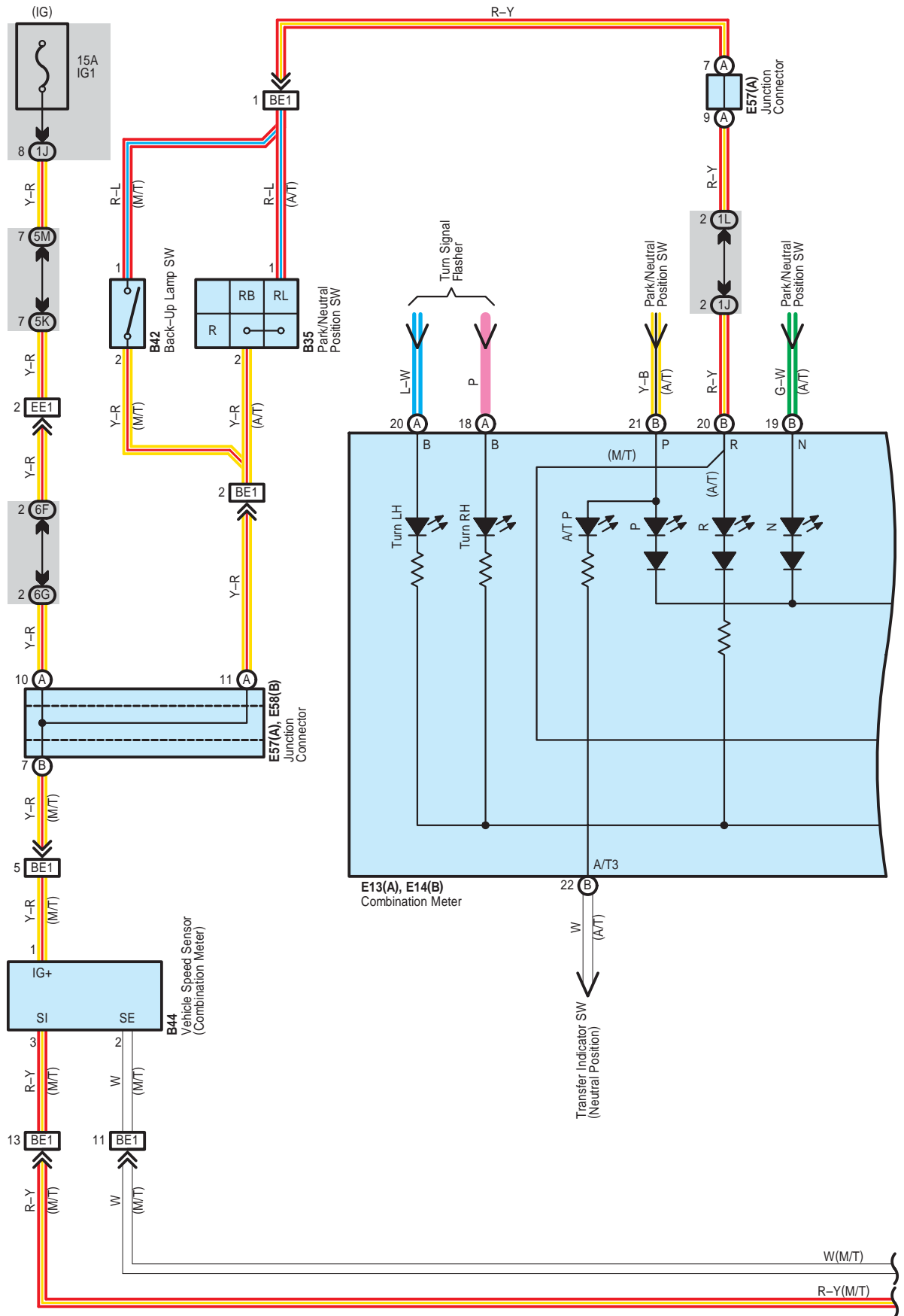

- * 1 : w/ Daytime Running Light
- * 2 : w/o Daytime Running Light

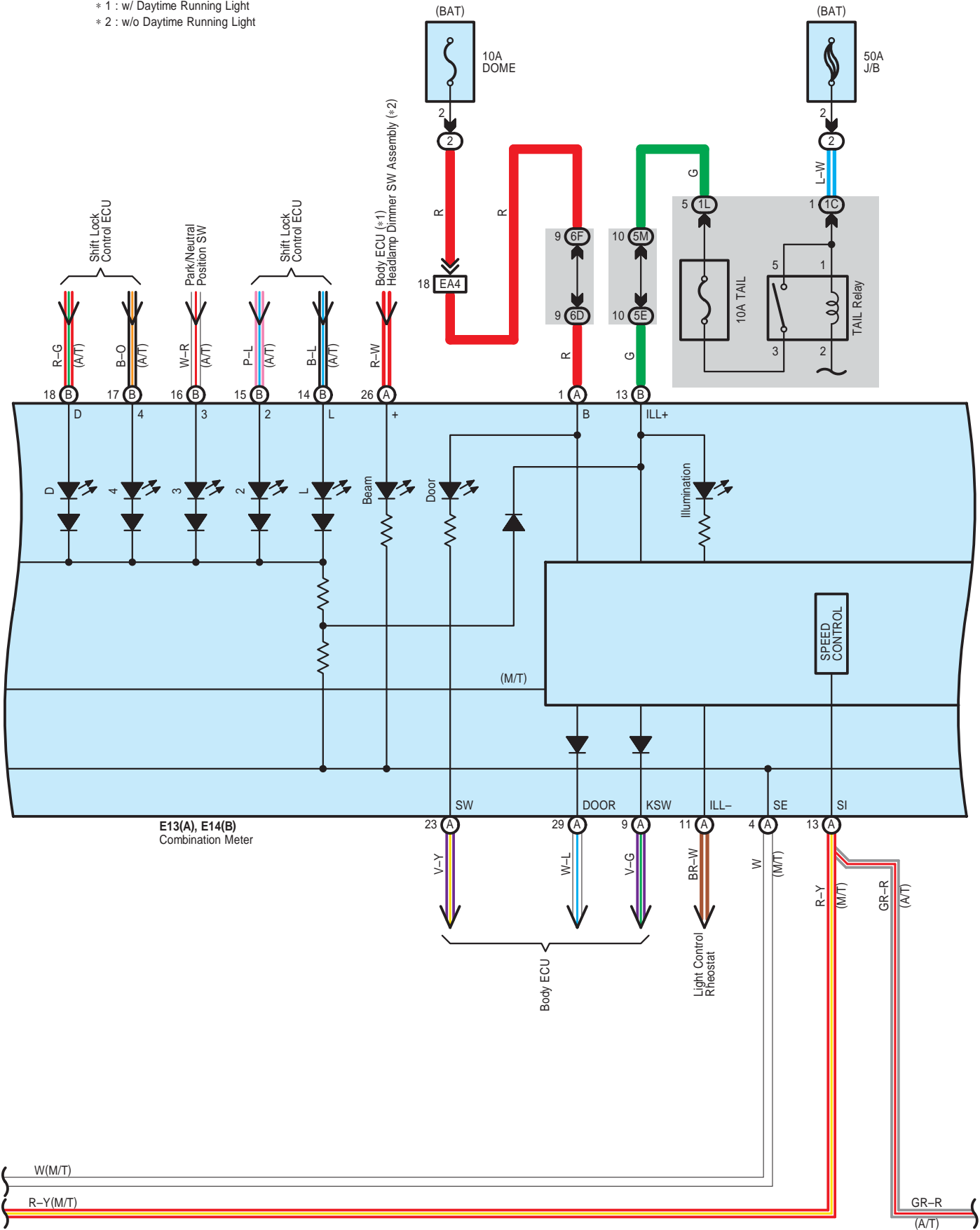

Combination Meter

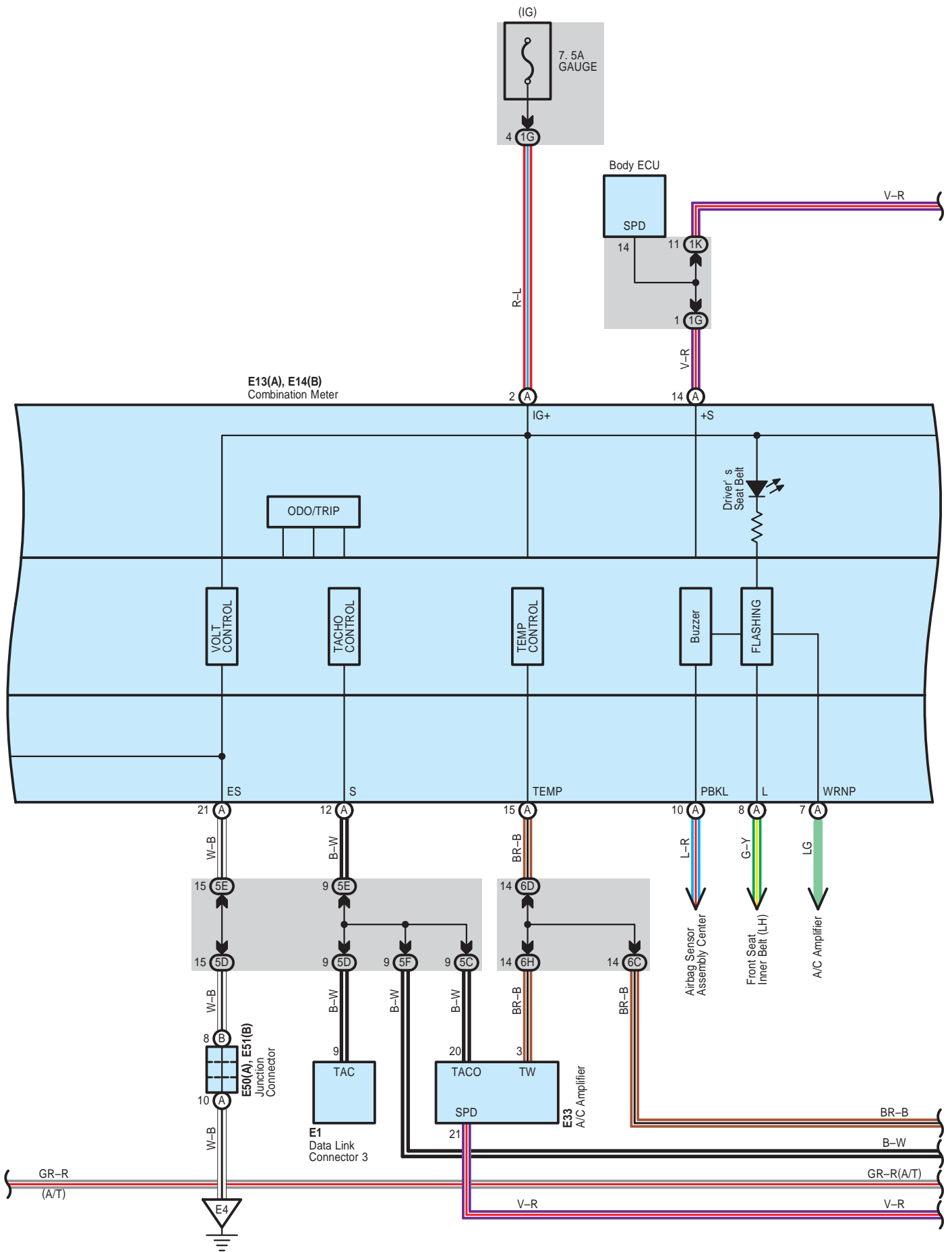

V-R V-R

E13(A), E14(B)
Combination Meter

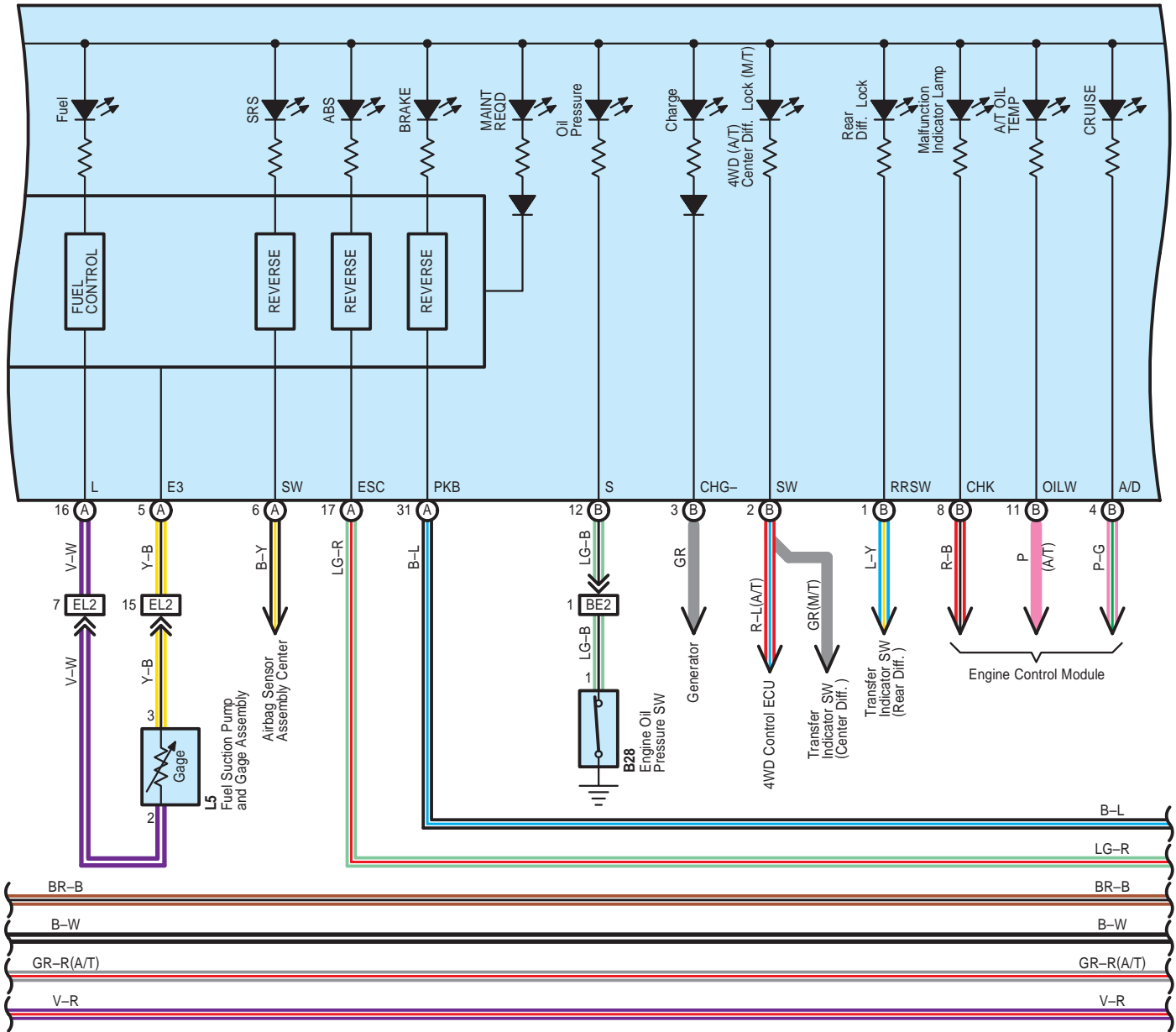

Combination Meter

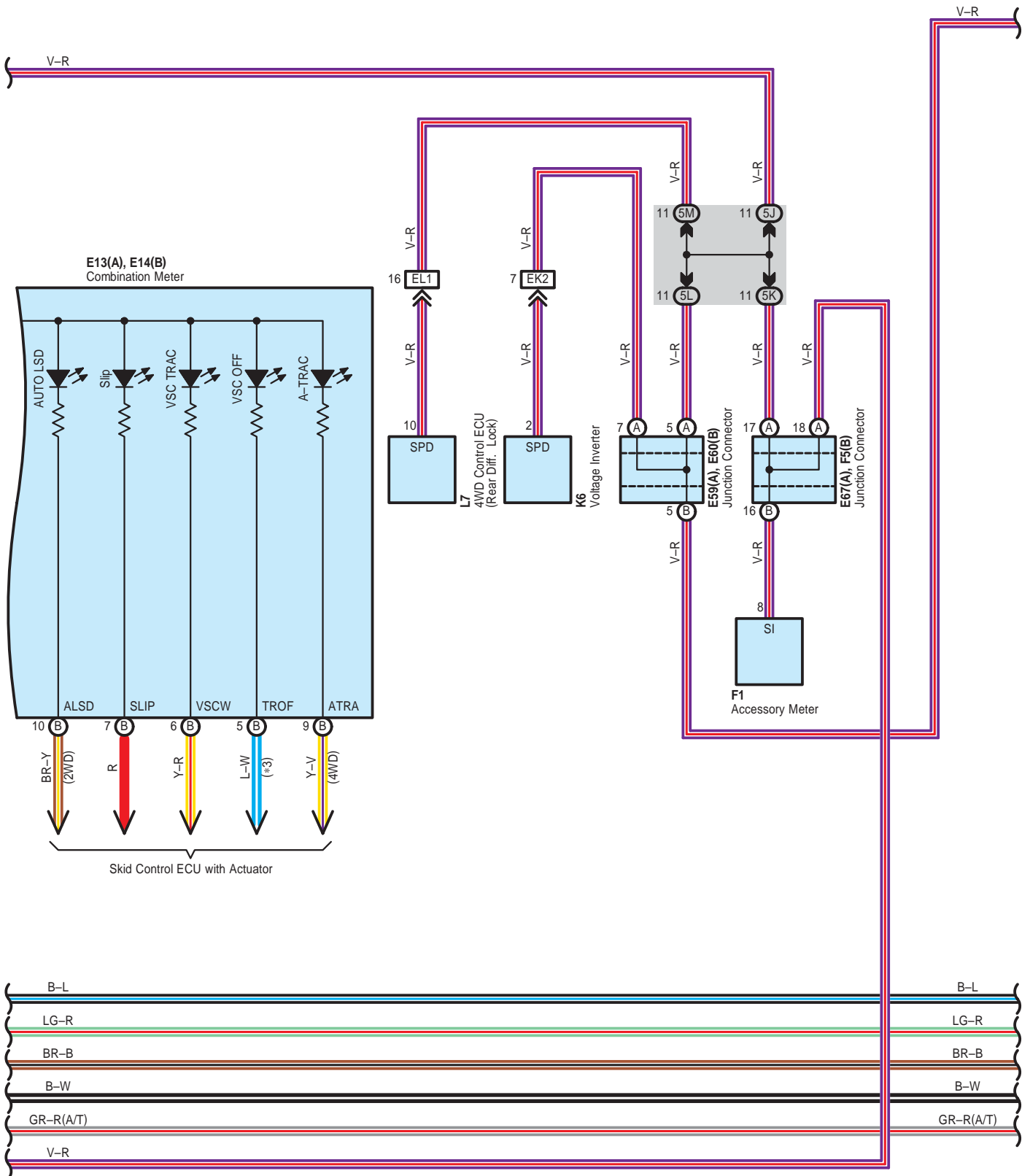

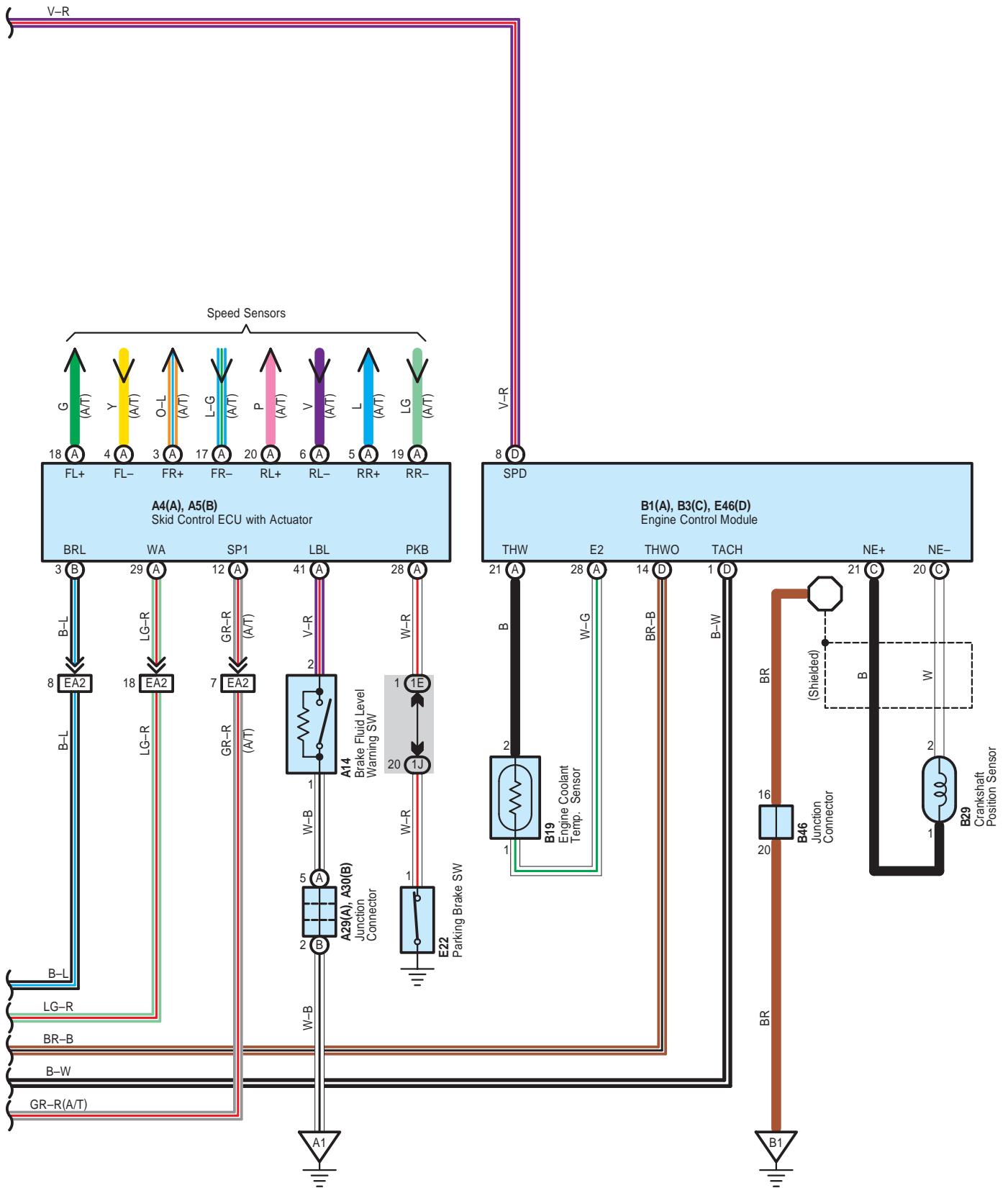

Combination Meter

: Parts Location

Code		See Page	Code		See Page	Code		See Page
A4	A	38	B42	40	E57	A	44	
A5	B	38	B44	40	E58	B	44	
A14		38	B46	45	E59	A	44	
A29	A	38	E1		42	E60	B	44
A30	B	38	E13	A	42	E67	A	44
B1	A	45	E14	B	42	F1		45
B3	C	45	E22		42	F5	B	45
B19		39	E33		43	K6		46
B28		40	E46	D	43	L5		46
B29		40	E50	A	44	L7		45
B35		40	E51	B	44			

: Relay Blocks

Code	See Page	Relay Blocks (Relay Block Location)
2	22	Engine Room R/B No.2 (Engine Compartment Left)

: Junction Block and Wire Harness Connector

Code	See Page	Junction Block and Wire Harness (Connector Location)
1C	24	Engine Room Main Wire and Driver Side J/B (Lower Finish Panel)
1E		
1G	25	Instrument Panel Wire and Driver Side J/B (Lower Finish Panel)
1J		
1K		
1L		
5C	28	Instrument Panel Wire and Center J/B LH (Instrument Panel LH)
5D		
5E		
5F		
5J		
5K		
5L		
5M		
6C	32	Instrument Panel Wire and Center J/B RH (Instrument Panel RH)
6D		
6F		
6G		
6H		

: Connector Joining Wire Harness and Wire Harness

Code	See Page	Joining Wire Harness and Wire Harness (Connector Location)
BE1	51	Engine Wire and Instrument Panel Wire (Upper the Glove Box)
BE2		
EA2	51	Instrument Panel Wire and Engine Room Main Wire (Left Kick Panel)
EA4		
EE1	51	Instrument Panel Wire and Instrument Panel Wire (Instrument Panel RH)
EK2	51	Instrument Panel Wire and Floor Wire (Right Kick Panel)
EL1	51	Instrument Panel Wire and Floor No.2 Wire (Left Kick Panel)
EL2		



: Ground Points

Code	See Page	Ground Points Location
A1	50	Left Fender Apron
B1	50	Rear Side of Right Bank Cylinder Block
E4	51	Left Kick Panel

Air Conditioning

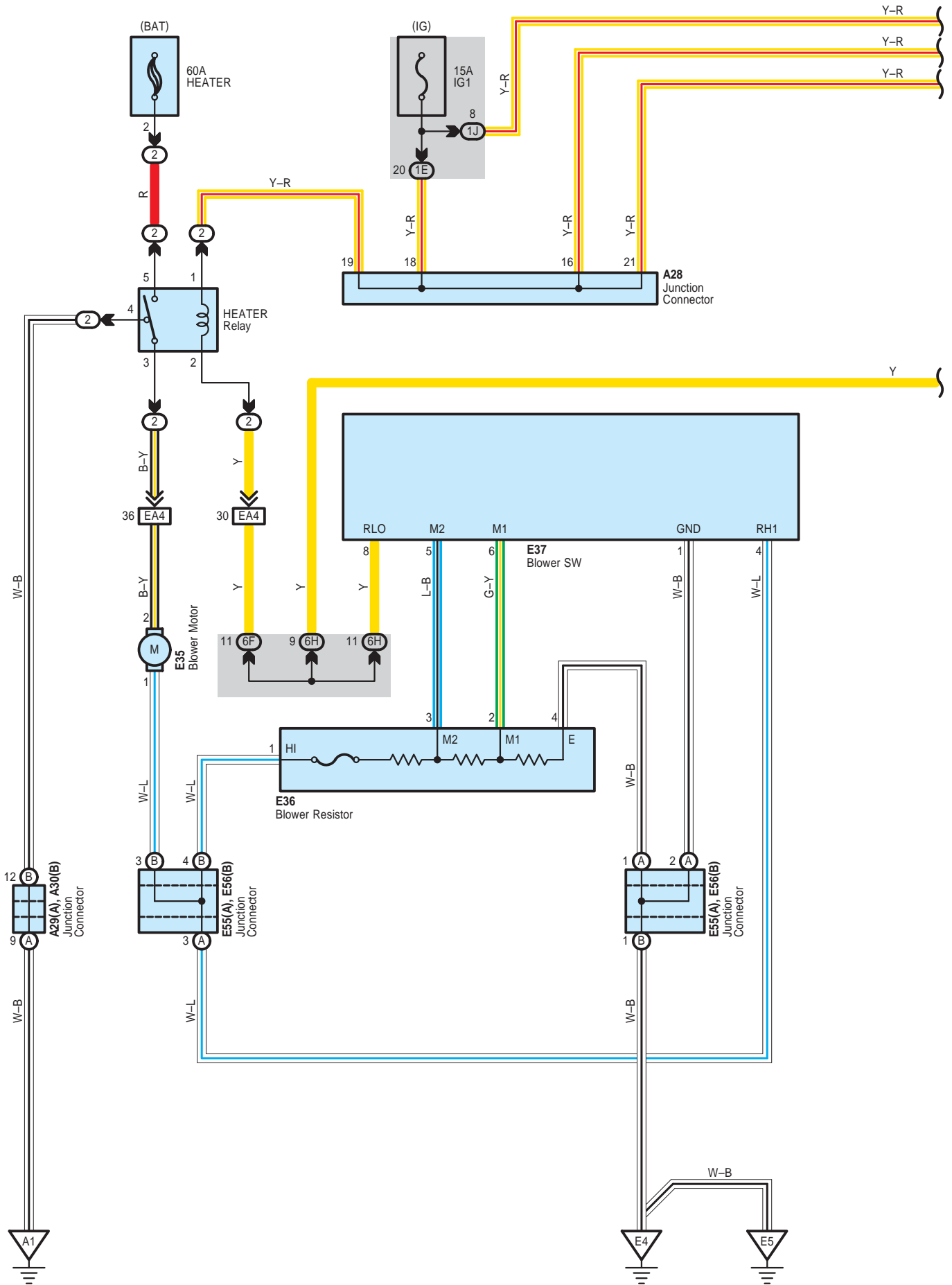

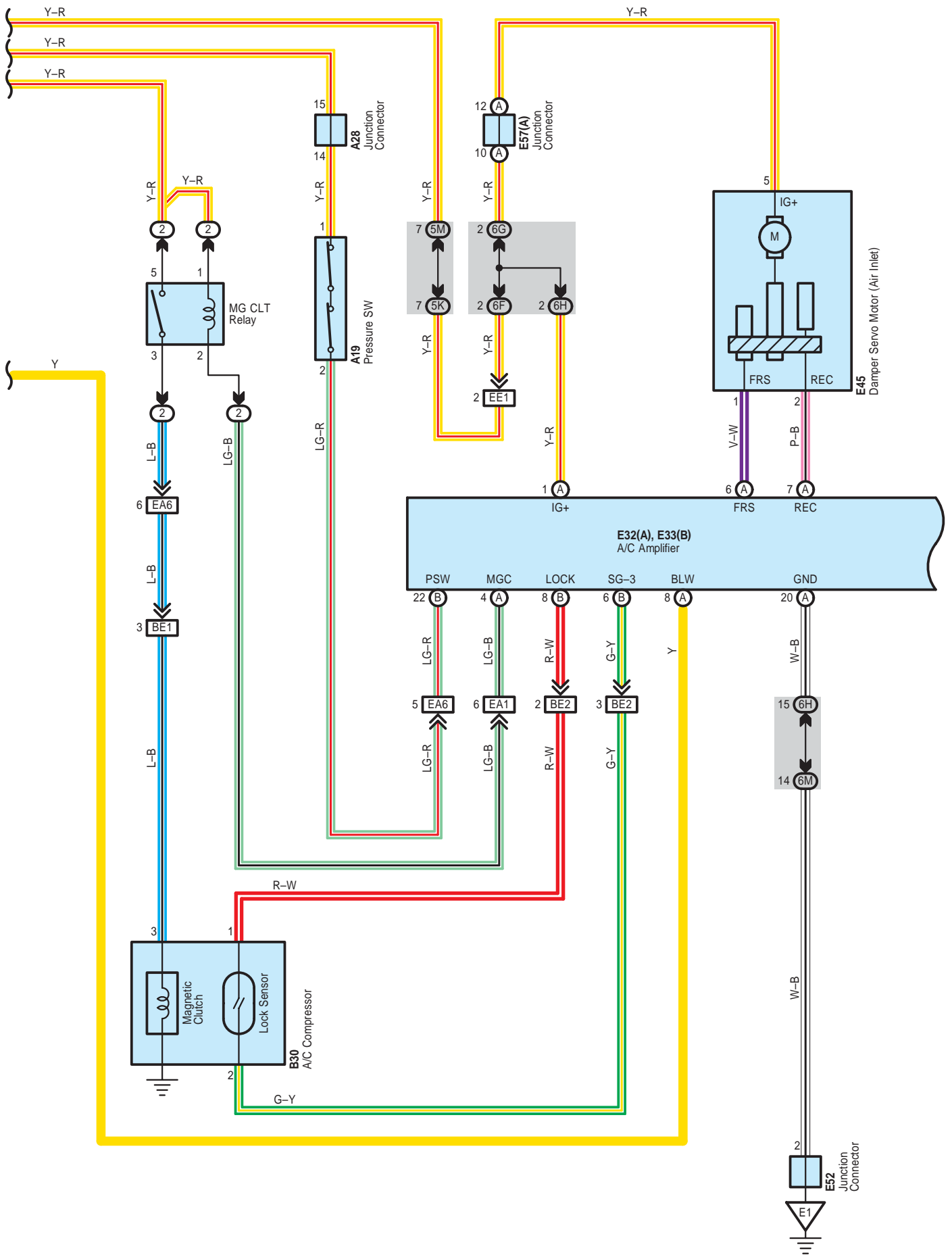

Air Conditioning

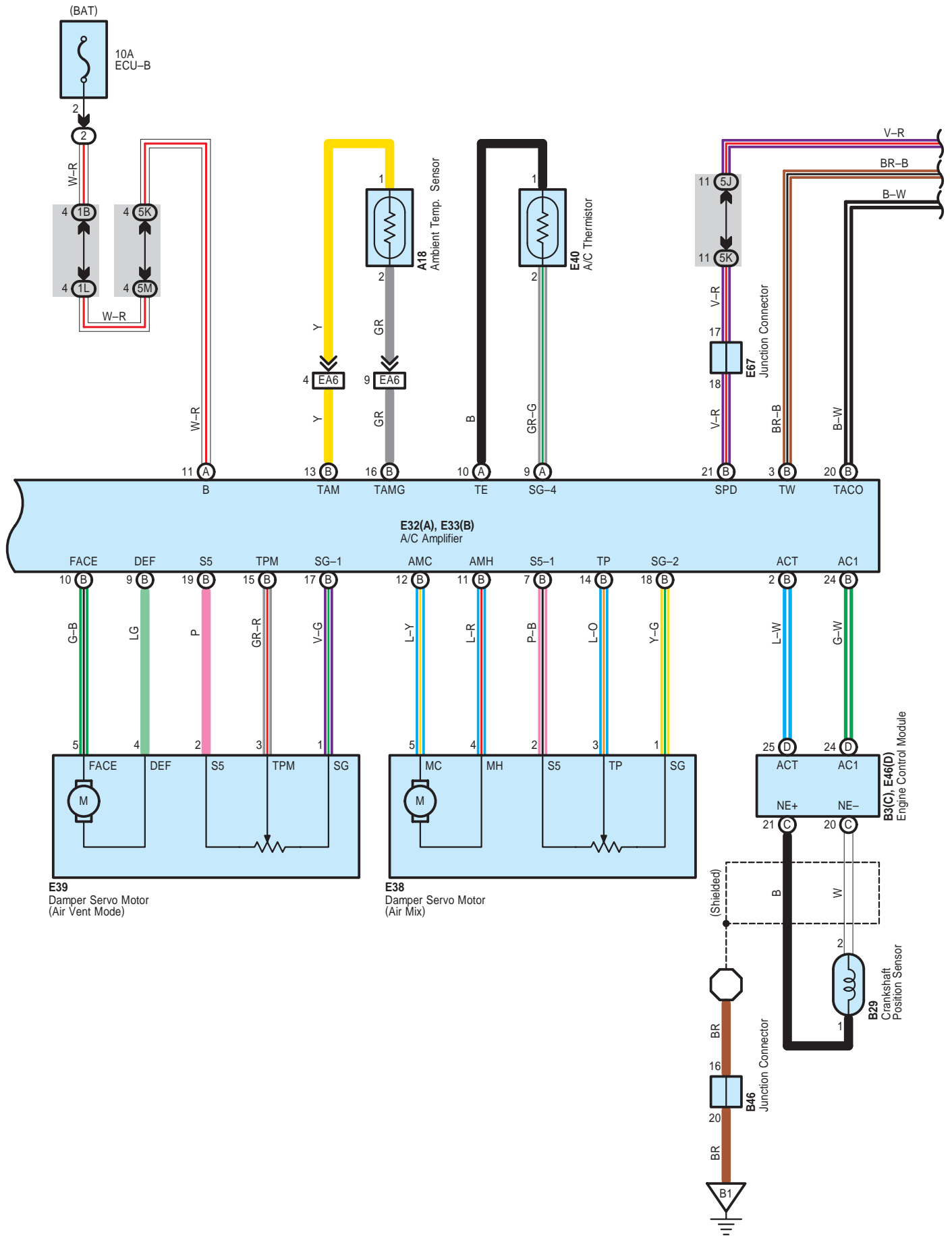

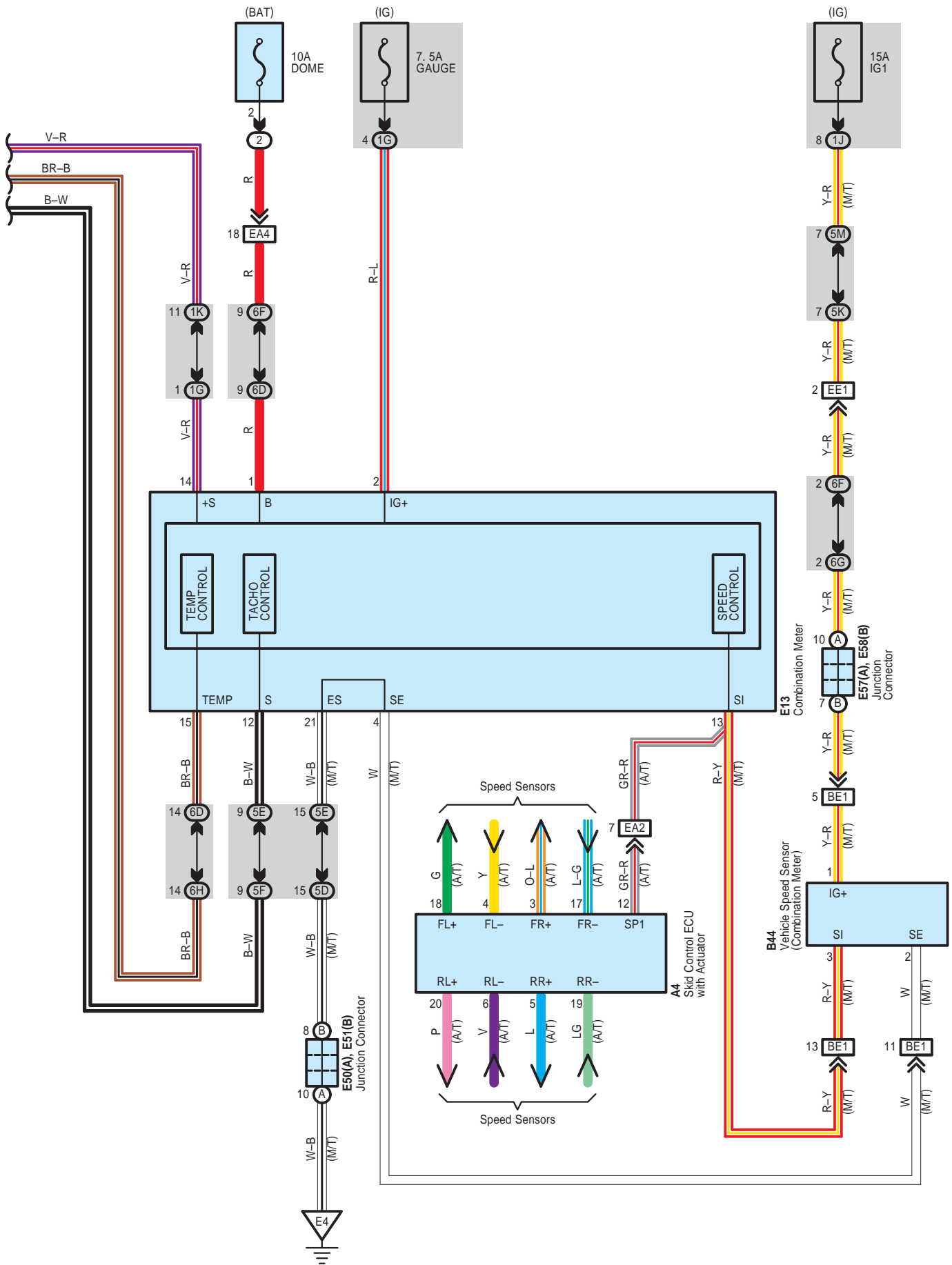

FJ CRUISER (EM0240U)

Air Conditioning

○ : Parts Location

Code	See Page	Code	See Page	Code	See Page
A4	38	B46	45	E45	43
A18	38	E13	42	E46	D 43
A19	38	E32	A 43	E50	A 44
A28	38	E33	B 43	E51	B 44
A29	A 38	E35	43	E52	44
A30	B 38	E36	43	E55	A 44
B3	C 45	E37	43	E56	B 44
B29	40	E38	43	E57	A 44
B30	40	E39	43	E58	B 44
B44	40	E40	43	E67	44

○ : Relay Blocks

Code	See Page	Relay Blocks (Relay Block Location)
2	22	Engine Room R/B No.2 (Engine Compartment Left)

○ : Junction Block and Wire Harness Connector

Code	See Page	Junction Block and Wire Harness (Connector Location)
1B	24	Engine Room Main Wire and Driver Side J/B (Lower Finish Panel)
1E		
1G	25	Instrument Panel Wire and Driver Side J/B (Lower Finish Panel)
1J		
1K		
1L		
5D	28	Instrument Panel Wire and Center J/B LH (Instrument Panel LH)
5E		
5F		
5J		
5K		
5M		
6D	32	Instrument Panel Wire and Center J/B RH (Instrument Panel RH)
6F		
6G		
6H		
6M		

□ : Connector Joining Wire Harness and Wire Harness

Code	See Page	Joining Wire Harness and Wire Harness (Connector Location)
BE1	51	Engine Wire and Instrument Panel Wire (Upper the Glove Box)
BE2		
EA1	51	Instrument Panel Wire and Engine Room Main Wire (Left Kick Panel)
EA2		
EA4		
EA6	51	Instrument Panel Wire and Engine Room Main Wire (Right Kick Panel)
EE1	51	Instrument Panel Wire and Instrument Panel Wire (Instrument Panel RH)

▽ : Ground Points

Code	See Page	Ground Points Location
A1	50	Left Fender Apron
B1	50	Rear Side of Right Bank Cylinder Block
E1	51	Instrument Panel Brace RH
E4	51	Left Kick Panel
E5	51	Right Kick Panel

I GROUND POINT

- * 1 : w/ Daytime Running Light
- * 2 : w/ Rear Wiper
- * 3 : w/ Cruise Control

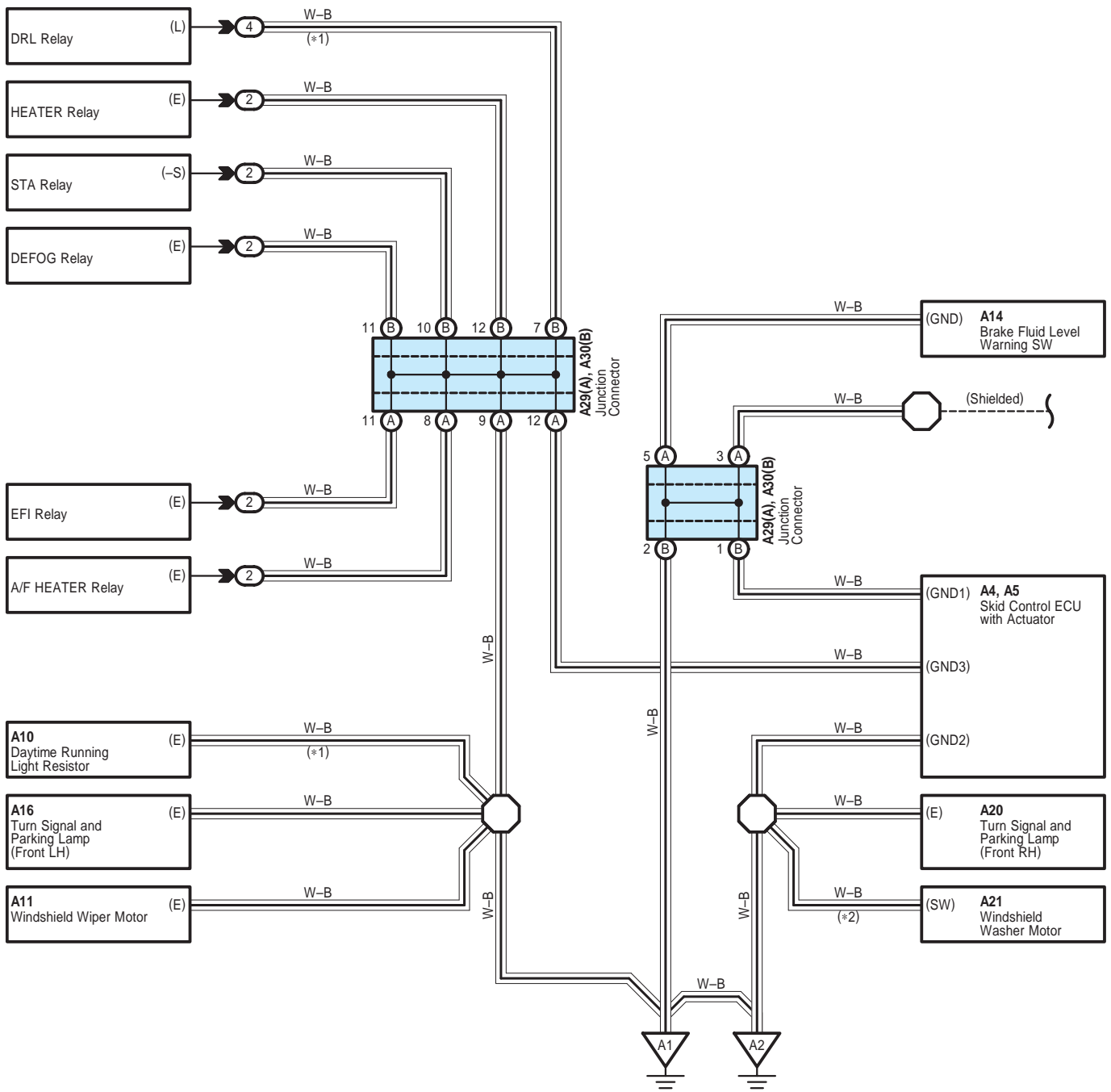

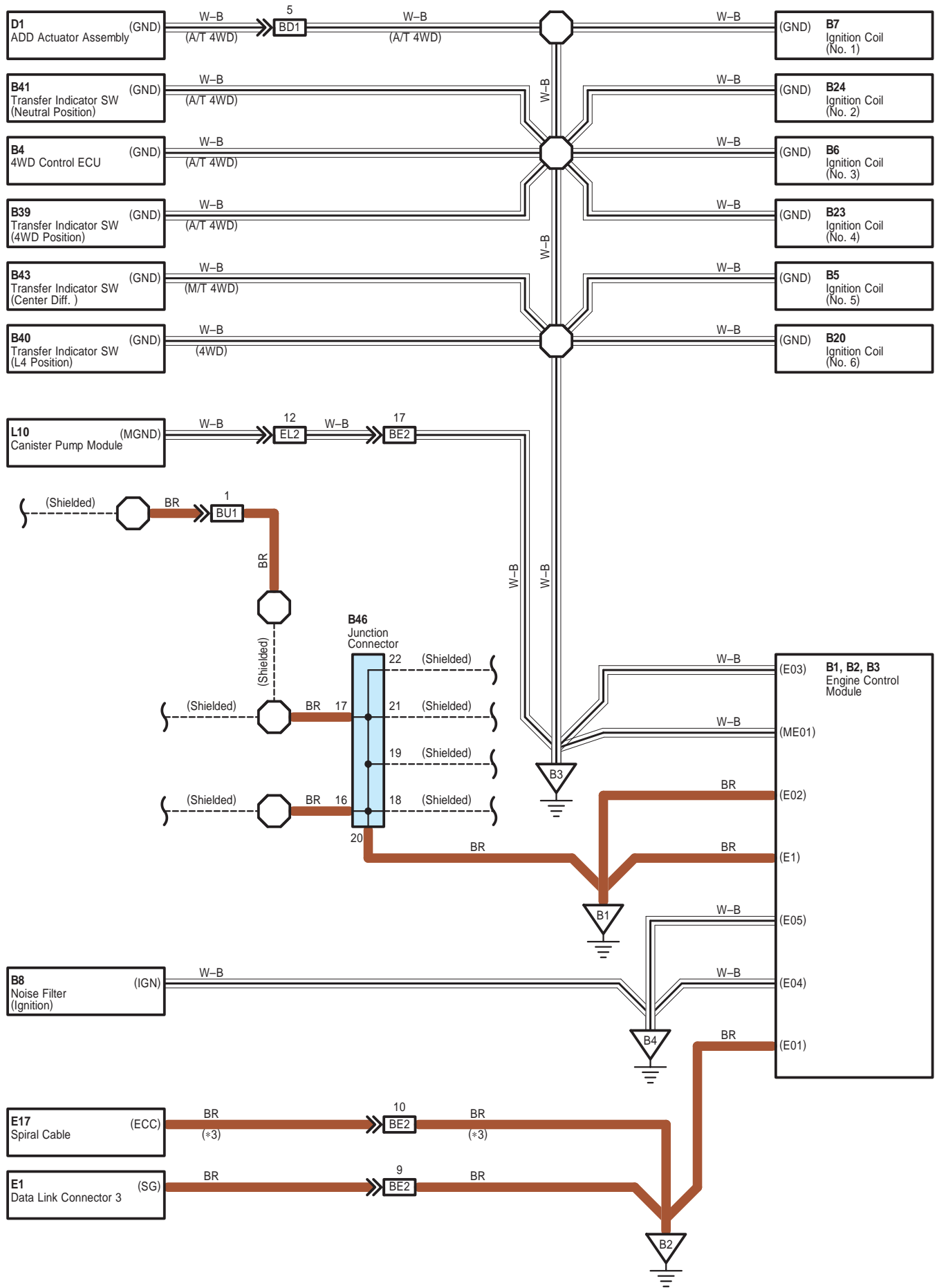

I GROUND POINT

* 4 : w/ Power Outlet (115V)
 * 5 : w/ Accessory Meter

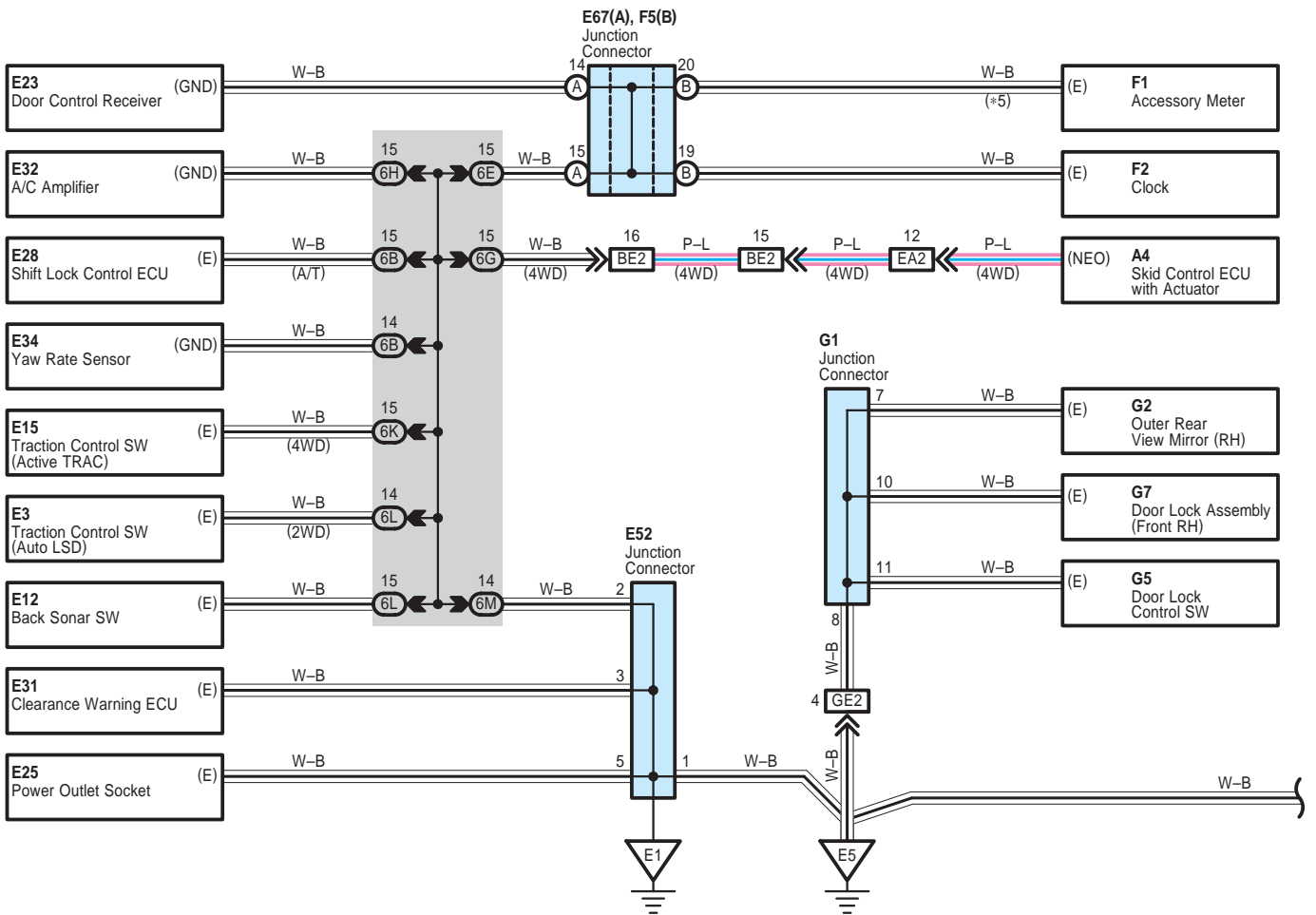
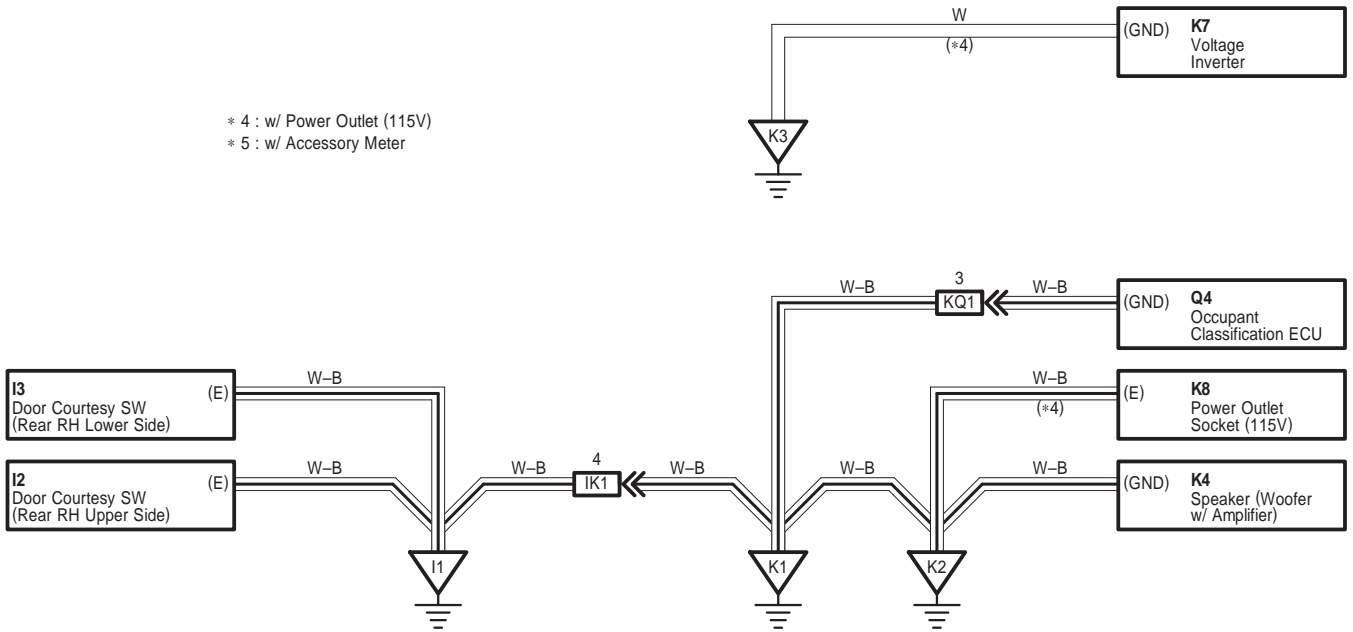

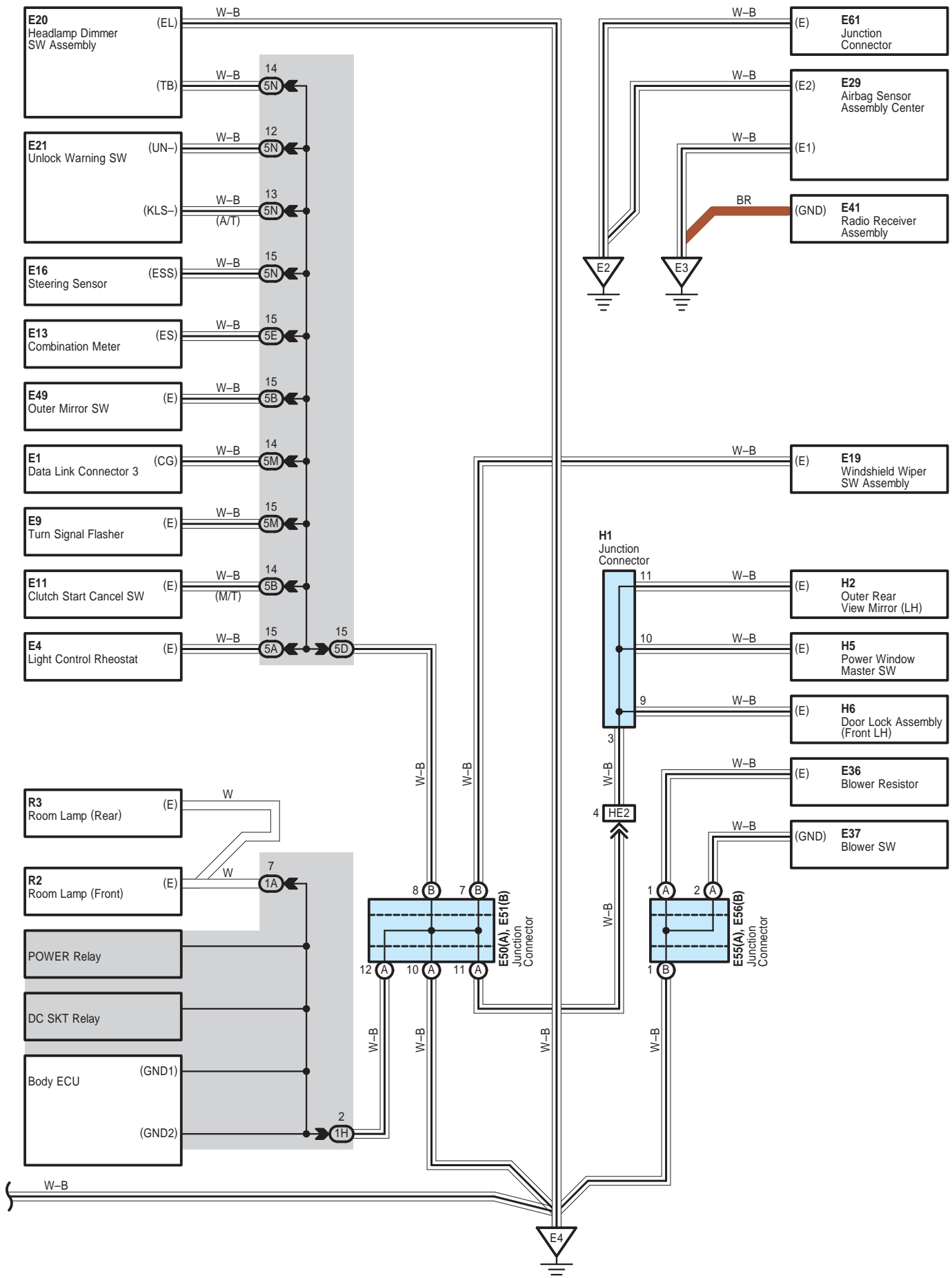

I GROUND POINT

* 6 : w/ Rear Diff. Lock

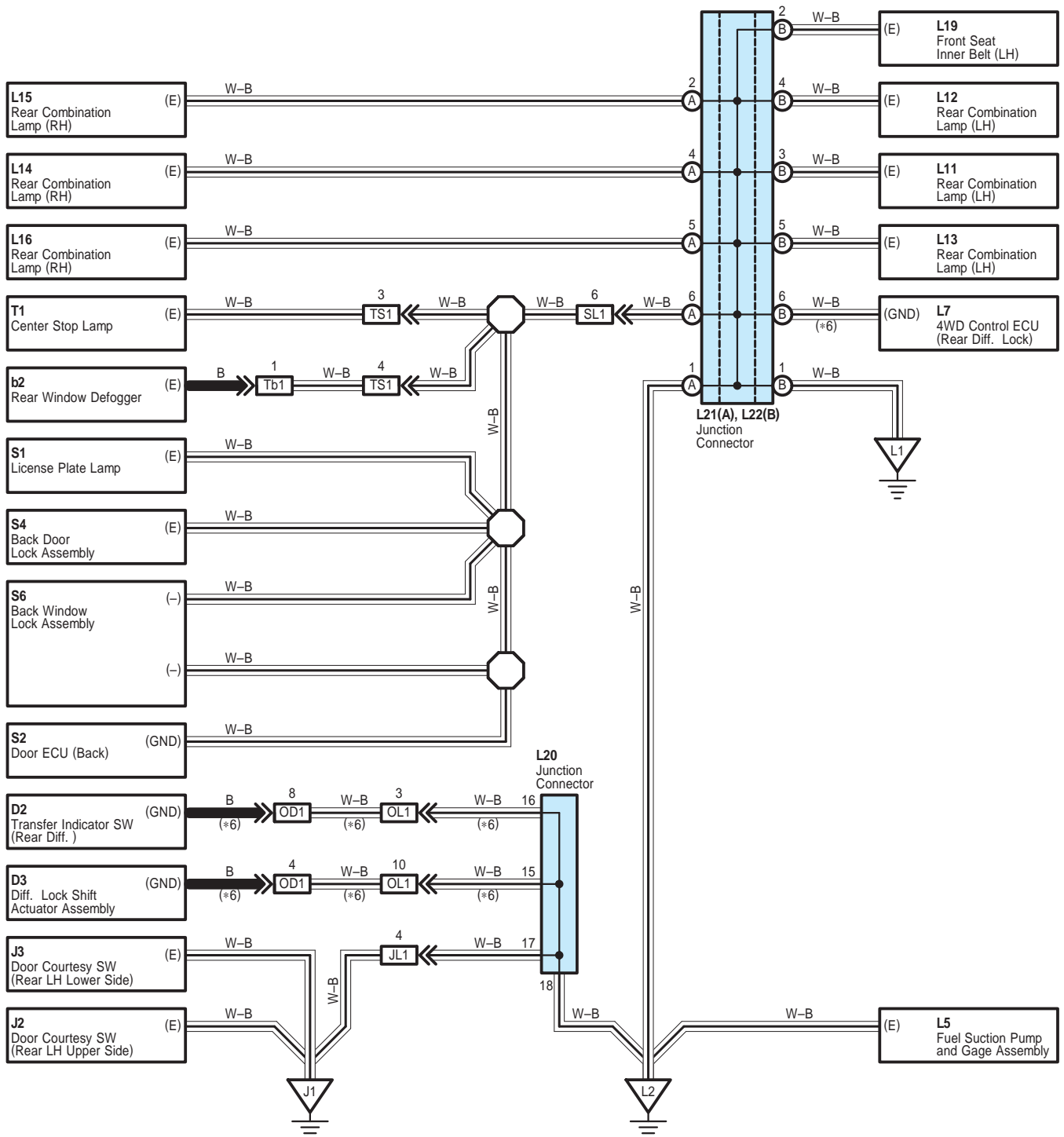

: Parts Location

Code		See Page	Code		See Page	Code		See Page
A29	A	38	E52		44	G1		47
A30	B	38	E55	A	44	H1		47
B46		45	E56	B	44	L20		46
E50	A	44	E67	A	44	L21	A	46
E51	B	44	F5	B	45	L22	B	46

: Relay Blocks

Code	See Page	Relay Blocks (Relay Block Location)
2	22	Engine Room R/B No.2 (Engine Compartment Left)
4	23	Engine Room R/B No.4 (Engine Compartment Left)

: Junction Block and Wire Harness Connector

Code	See Page	Junction Block and Wire Harness (Connector Location)
1A	24	Roof Wire and Driver Side J/B (Lower Finish Panel)
1H	25	Instrument Panel Wire and Driver Side J/B (Lower Finish Panel)
5A	28	Instrument Panel Wire and Center J/B LH (Instrument Panel LH)
5B		
5D		
5E		
5M		
5N		
6B	32	Instrument Panel Wire and Center J/B RH (Instrument Panel RH)
6E		
6G		
6H		
6K		
6L		
6M		

: Connector Joining Wire Harness and Wire Harness

Code	See Page	Joining Wire Harness and Wire Harness (Connector Location)
BD1	50	Engine Wire and Differential Wire (Near the Front Differential)
BE2	51	Engine Wire and Instrument Panel Wire (Upper the Glove Box)
BU1	50	Engine Wire and Sensor Wire (Rear Side of Right Bank Cylinder Block)
EA2	51	Instrument Panel Wire and Engine Room Main Wire (Left Kick Panel)
EL2	51	Instrument Panel Wire and Floor No.2 Wire (Left Kick Panel)
GE2	51	Front Door RH Wire and Instrument Panel Wire (Right Kick Panel)
HE2	51	Front Door LH Wire and Instrument Panel Wire (Left Kick Panel)
IK1	52	Rear Door No.1 Wire and Floor Wire (Right Quarter Panel)
JL1	52	Rear Door No.2 Wire and Floor No.2 Wire (Left Quarter Panel)
KQ1	53	Floor Wire and Seat No.1 Wire (Under the Front Seat RH)
OD1	52	Frame Wire and Differential Wire (No.6 Crossmember)
OL1	52	Frame Wire and Floor No.2 Wire (Under the Rear Seat)
SL1	52	Back Door No.1 Wire and Floor No.2 Wire (Left Quarter Panel)
TS1	52	Back Door No.2 Wire and Back Door No.1 Wire (Left Side of Back Door)
Tb1	52	Back Door No.2 Wire and Rear Window No.1 Wire (Upper Side of Back Door)

I GROUND POINT



: Ground Points

Code	See Page	Ground Points Location
A1	50	Left Fender Apron
A2	50	Right Fender Apron
B1	50	Rear Side of Right Bank Cylinder Block
B2		
B3	50	Rear Side of Left Bank Cylinder Block
B4		
E1	51	Instrument Panel Brace RH
E2	51	Instrument Panel Brace LH
E3	51	Instrument Panel Brace RH
E4	51	Left Kick Panel
E5	51	Right Kick Panel
I1	52	Access Door RH
J1	52	Access Door LH
K1	52	Floor Seat Crossmember RH
K2	52	Rear Wheel House RH
K3		
L1	52	Floor Seat Crossmember LH
L2	52	Left Quarter Panel

J POWER SOURCE (Current Flow Chart)

The chart below shows the route by which current flows from the battery to each electrical source (Fusible Link, Circuit Breaker, Fuse, etc.) and other Parts.

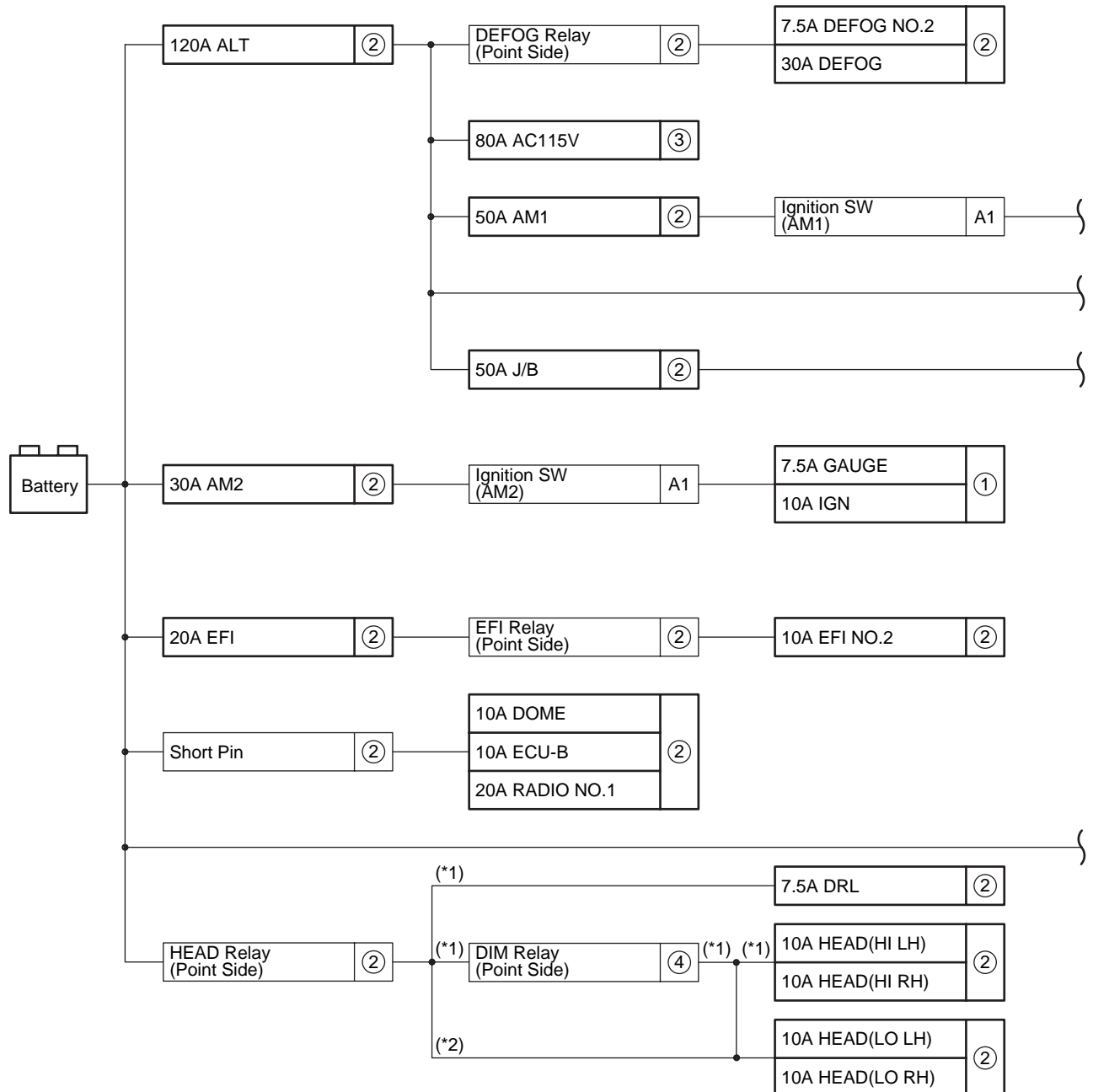

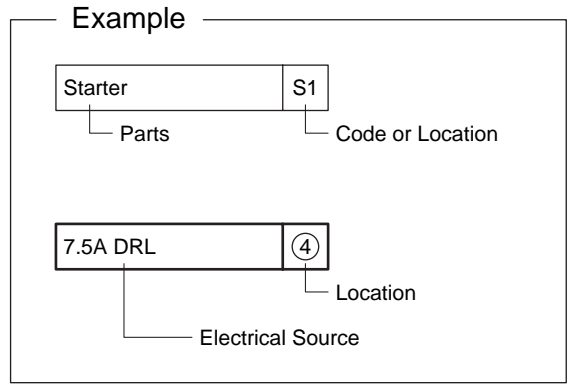
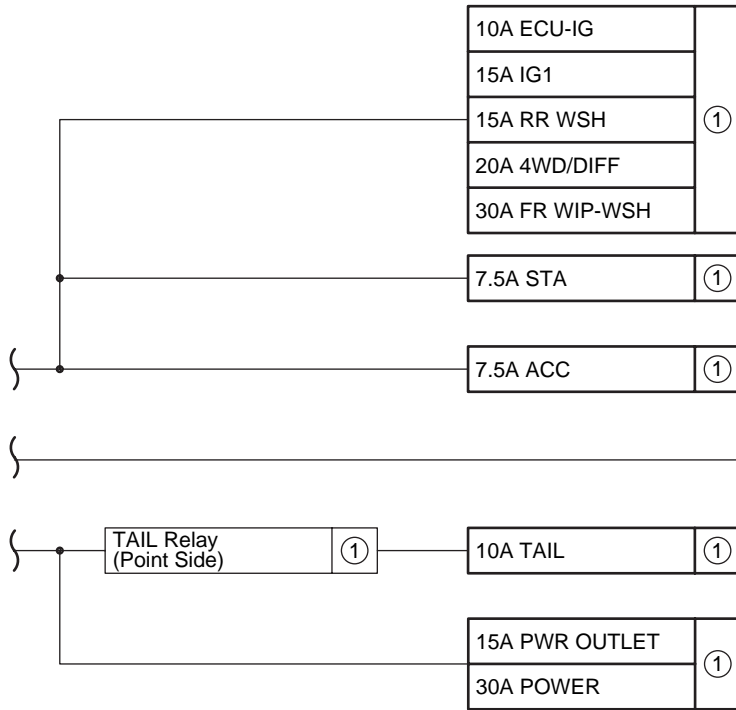

7.5A OBD	②
10A STOP	
15A AUX LP	
15A OFFROAD LP	
15A TOWING TAIL	

* 1:w/ Daytime Running Light
 * 2:w/o Daytime Running Light

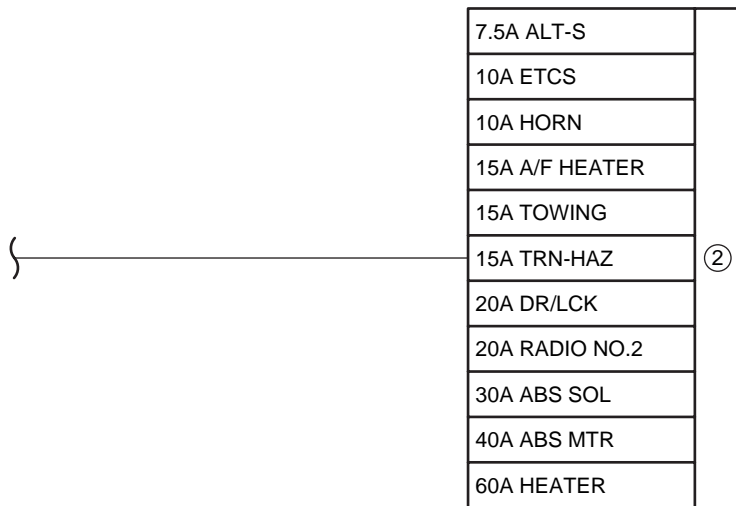

[LOCATION]

- ① : Driver Side J/B (See Page 24)
- ② : Engine Room R/B No.2 (See Page 22)
- ③ : Engine Room R/B No.3 (See Page 23)
- ④ : Engine Room R/B No.4 (See Page 23)

J POWER SOURCE (Current Flow Chart)

Driver Side J/B (See Page 24)

Fuse		System	Page
7.5A	ACC	Accessory Meter	230
		Audio System	236
		Clock	228
		Door Lock Control	150
		Headlight	94
		Interior Light	108
		Light Auto Turn Off System	100
		Power Outlet (12V)	218
		Power Window	146
		Rear Wiper and Washer	142
		Remote Control Mirror	212
		Seat Belt Warning	130
		Shift Lock	210
		Taillight and Illumination	118
Wireless Door Lock Control	158		
7.5A	GAUGE	ABS, TRAC, VSC and Auto LSD	186
		Accessory Meter	230
		Air Conditioning	250
		Charging	68
		Combination Meter	242
		Cruise Control	176
		Electronically Controlled Transmission and A/T Indicator	166
		Engine Control	70
		Interior Light	108
		Power Outlet (115V)	214
		Rear Differential Lock	200
		Rear Window Defogger	224
		Seat Belt Warning	130
		SRS	203
4WD	196		
7.5A	STA	Cruise Control	176
		Electronically Controlled Transmission and A/T Indicator	166
		Engine Control	70
		Starting	60
10A	ECU-IG	ABS, TRAC, VSC and Auto LSD	186
		Cruise Control	176
		Door Lock Control	150
		Headlight	94
		Interior Light	108
		Light Auto Turn Off System	100
		Power Outlet (115V)	214
		Power Window	146
Rear Wiper and Washer	142		

* These are the page numbers of the first page on which the related system is shown.

Fuse		System	Page
10A	ECU-IG	Seat Belt Warning	130
		Shift Lock	210
		Taillight and Illumination	118
		Wireless Door Lock Control	158
10A	IGN	ABS, TRAC, VSC and Auto LSD	186
		Cruise Control	176
		Electronically Controlled Transmission and A/T Indicator	166
		Engine Control	70
		Seat Belt Warning	130
		SRS	203
10A	TAIL	Clock	228
		Combination Meter	242
		Engine Control	70
		Taillight and Illumination	118
15A	IG1	ABS, TRAC, VSC and Auto LSD	186
		Accessory Meter	230
		Air Conditioning	250
		Back-Up Light	126
		Charging	68
		Combination Meter	242
		Cruise Control	176
		Electric Tension Reducer	222
		Electronically Controlled Transmission and A/T Indicator	166
		Engine Control	70
		Power Outlet (115V)	214
		Rear Differential Lock	200
		Rear Window Defogger	224
		Seat Belt Warning	130
		SRS	203
		Starting	60
Stop Light	124		
TOYOTA Parking Assist (Clearance Sonar)	234		
Turn Signal and Hazard Warning Light	104		
4WD	196		
15A	PWR OUTLET	Power Outlet (12V)	218
15A	RR WSH	Rear Wiper and Washer	142
20A	4WD/DIFF	Rear Differential Lock	200
		4WD	196
30A	FR WIP-WSH	Front Wiper and Washer	138
30A	POWER	Door Lock Control	150
		Interior Light	108
		Power Window	146
		Rear Wiper and Washer	142

* These are the page numbers of the first page on which the related system is shown.

J POWER SOURCE (Current Flow Chart)

Engine Room R/B No.2 (See Page 22)

Fuse		System	Page
7.5A	ALT-S	Charging	68
7.5A	DEFOG NO.2	Engine Control Rear Window Defogger	70 224
7.5A	DRL	Headlight	94
7.5A	OBD	Data Link Connector 3	86
10A	DOME	ABS, TRAC, VSC and Auto LSD	186
		Accessory Meter	230
		Air Conditioning	250
		Clock	228
		Combination Meter	242
		Cruise Control	176
		Electronically Controlled Transmission and A/T Indicator	166
		Engine Control	70
		Interior Light	108
		Key Reminder	128
		Power Outlet (115V)	214
		Rear Differential Lock	200
Rear Window Defogger	224		
Seat Belt Warning	130		
Wireless Door Lock Control	158		
10A	ECU-B	ABS, TRAC, VSC and Auto LSD	186
		Air Conditioning	250
		Door Lock Control	150
		Headlight	94
		Interior Light	108
		Key Reminder	128
		Light Auto Turn Off System	100
		Power Window	146
		Rear Wiper and Washer	142
		Seat Belt Warning	130
		SRS	203
		Taillight and Illumination	118
Wireless Door Lock Control	158		
10A	EFI NO.2	Electronically Controlled Transmission and A/T Indicator	166
		Engine Control	70
10A	ETCS	Cruise Control	176
		Electronically Controlled Transmission and A/T Indicator	166
		Engine Control	70
10A	HEAD(HI LH)	Headlight	94
10A	HEAD(HI RH)	Headlight	94
10A	HEAD(LO LH)	Headlight	94
10A	HEAD(LO RH)	Headlight	94

* These are the page numbers of the first page on which the related system is shown.

Fuse		System	Page
10A	HORN	Horn	220
		Wireless Door Lock Control	158
10A	STOP	ABS, TRAC, VSC and Auto LSD	186
		Cruise Control	176
		Electronically Controlled Transmission and A/T Indicator	166
		Engine Control	70
		Shift Lock	210
		Stop Light	124
15A	A/F HEATER	Engine Control	70
15A	TRN-HAZ	Turn Signal and Hazard Warning Light	104
20A	DR/LCK	Door Lock Control	150
		Wireless Door Lock Control	158
20A	EFI	Cruise Control	176
		Electronically Controlled Transmission and A/T Indicator	166
		Engine Control	70
20A	RADIO NO.1	Audio System	236
20A	RADIO NO.2	Audio System	236
30A	ABS SOL	ABS, TRAC, VSC and Auto LSD	186
30A	AM2	Engine Control	70
		Ignition	64
		Starting	60
30A	DEFOG	Rear Window Defogger	224
40A	ABS MTR	ABS, TRAC, VSC and Auto LSD	186
50A	AM1	Starting	60
50A	J/B	Clock	228
		Combination Meter	242
		Engine Control	70
		Light Auto Turn Off System	100
		Taillight and Illumination	118
		Wireless Door Lock Control	158
60A	HEATER	Air Conditioning	250
120A	ALT	Charging	68
		Engine Control	70
		Rear Window Defogger	224
		Starting	60

Engine Room R/B No.3 (See Page 23)

Fuse		System	Page
80A	AC115V	Power Outlet (115V)	214

* These are the page numbers of the first page on which the related system is shown.

K CONNECTOR LIST

A1

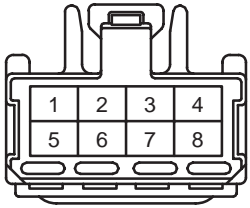

A2
Black

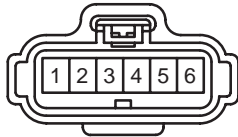

A3

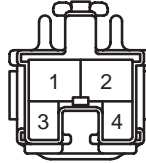

A4
Black

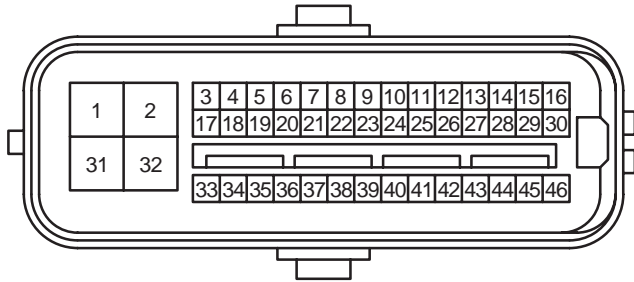

A5
Black

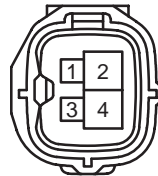

A6
Black



A7

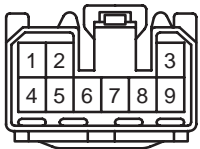

A8
Gray

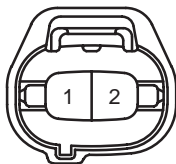

A9
Black



A10
Gray

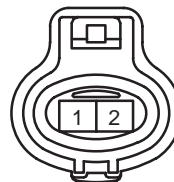

A11
Black



A12
Black



A13



A14
Gray

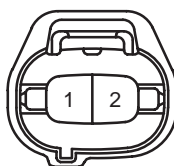

A15
Yellow



A16
Gray



A17
Black



A18
Black



A19
Gray

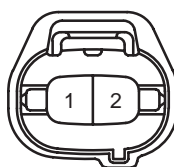

A20
Gray



A21
Dark Gray



A22
Yellow



A23
Black

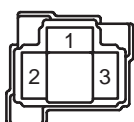

A24
Black

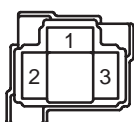

A25



A26

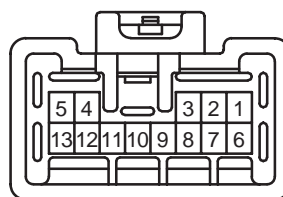

A27
Black

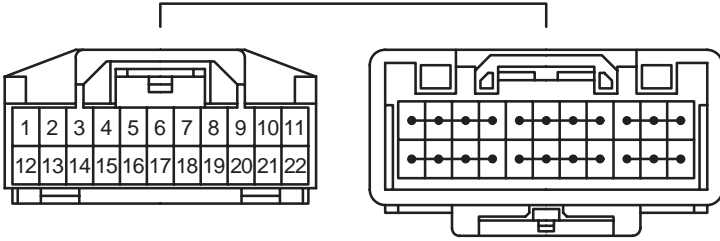

A28

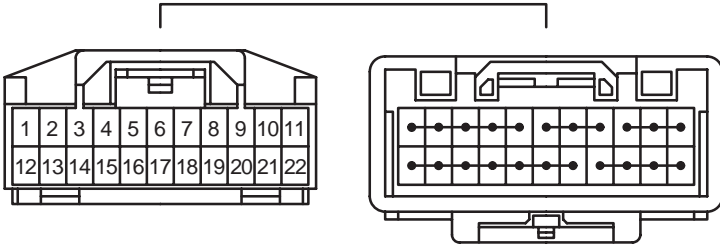

A29
Blue

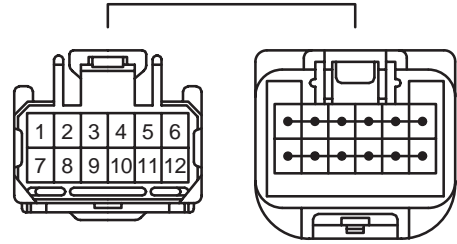

A30
Blue

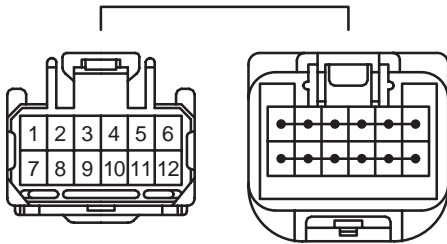

A31
Black



B1

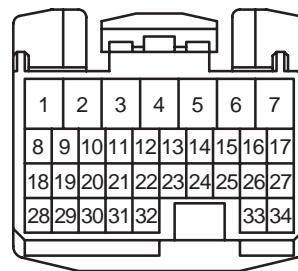

B2

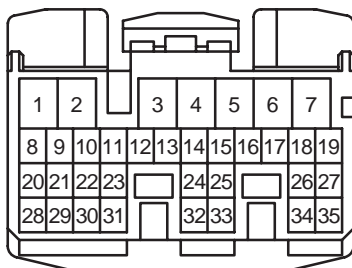

B3

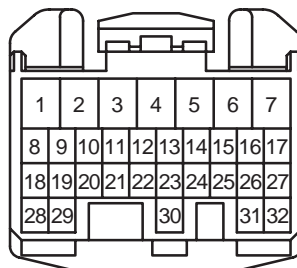

B4
Green

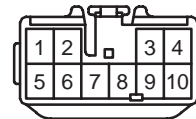

B5
Black

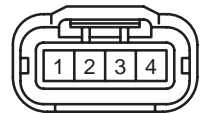

B6
Black

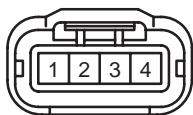

B7
Black

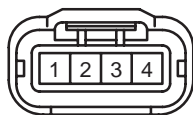

B8
Gray



B9
Gray

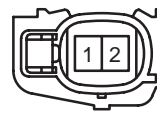

B10
Gray

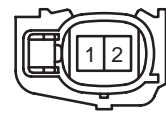

K CONNECTOR LIST

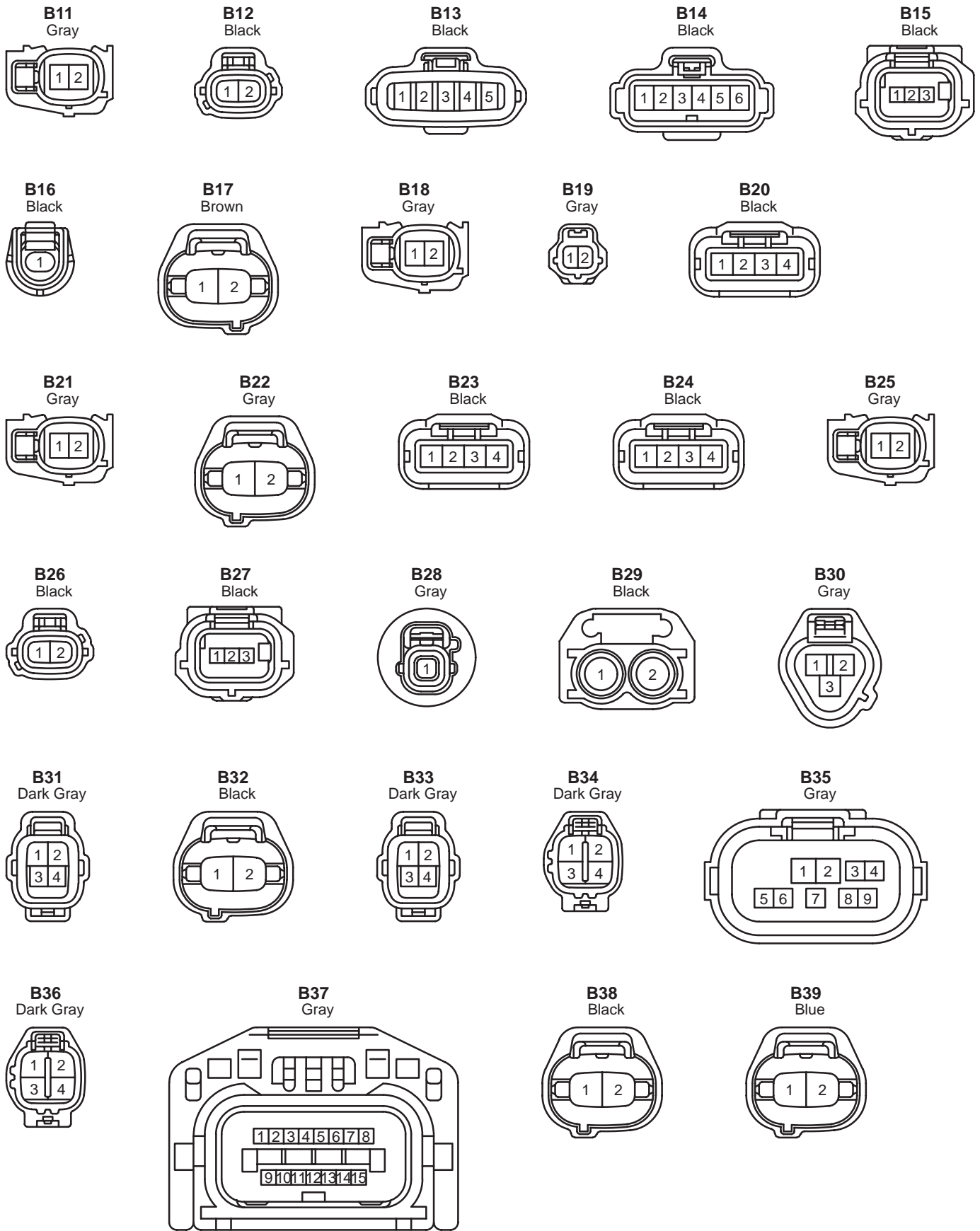

B40
Blue

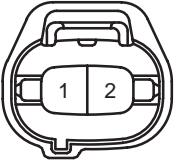

B41
Gray

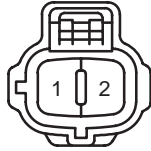

B42
Gray



B43
Blue

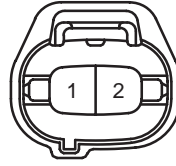

B44
Black



B45
Blue

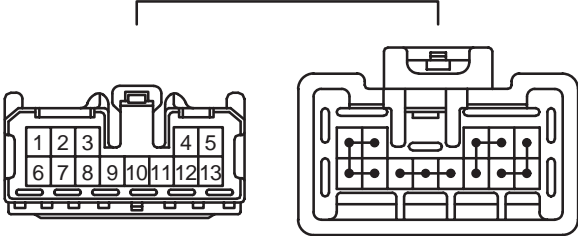

B46

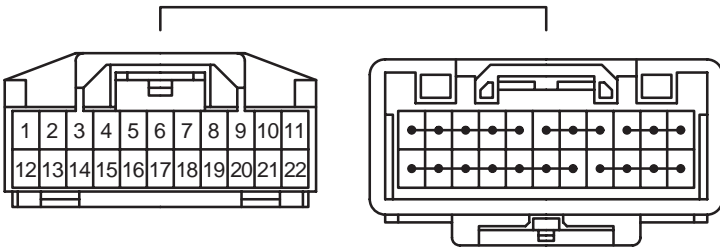

C1



C2
Black



C3
Black



C4



D1
Black

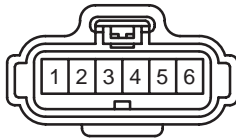

D2
Gray



D3
Gray



E1

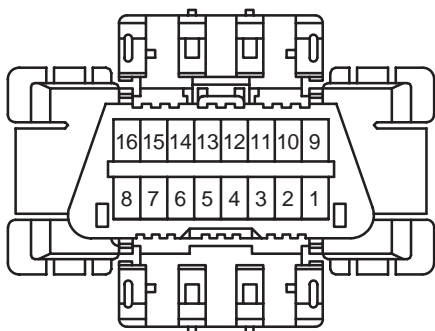

E2
Gray

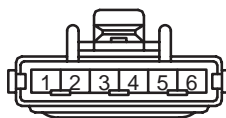

E3
Blue

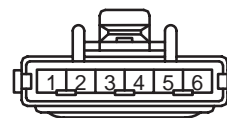

E4
Blue



K CONNECTOR LIST

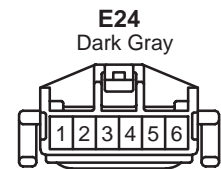
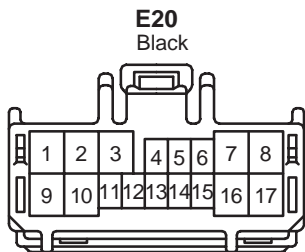
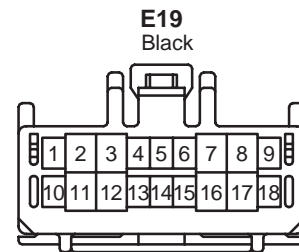
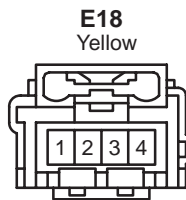
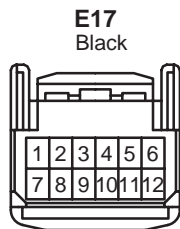
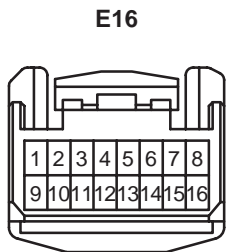
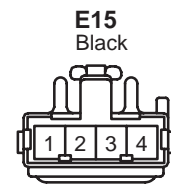
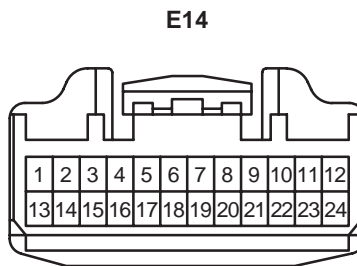
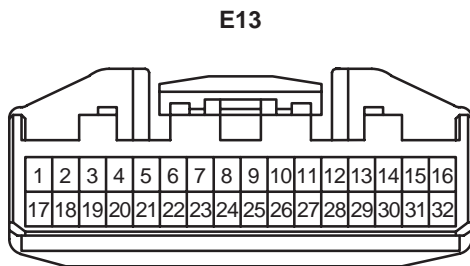
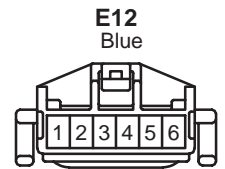
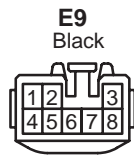
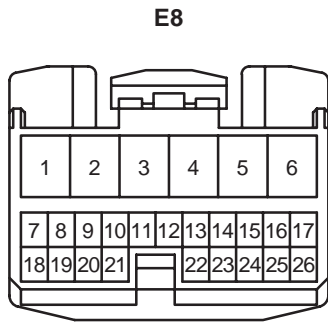
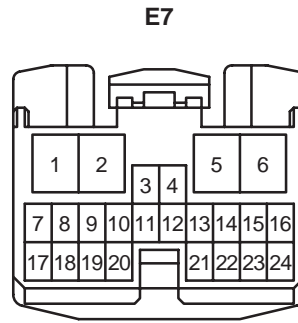
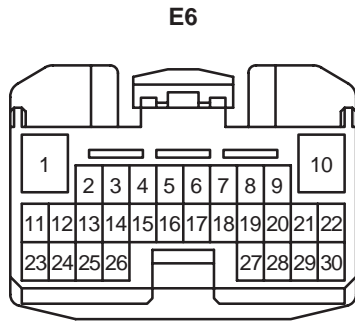
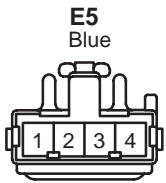

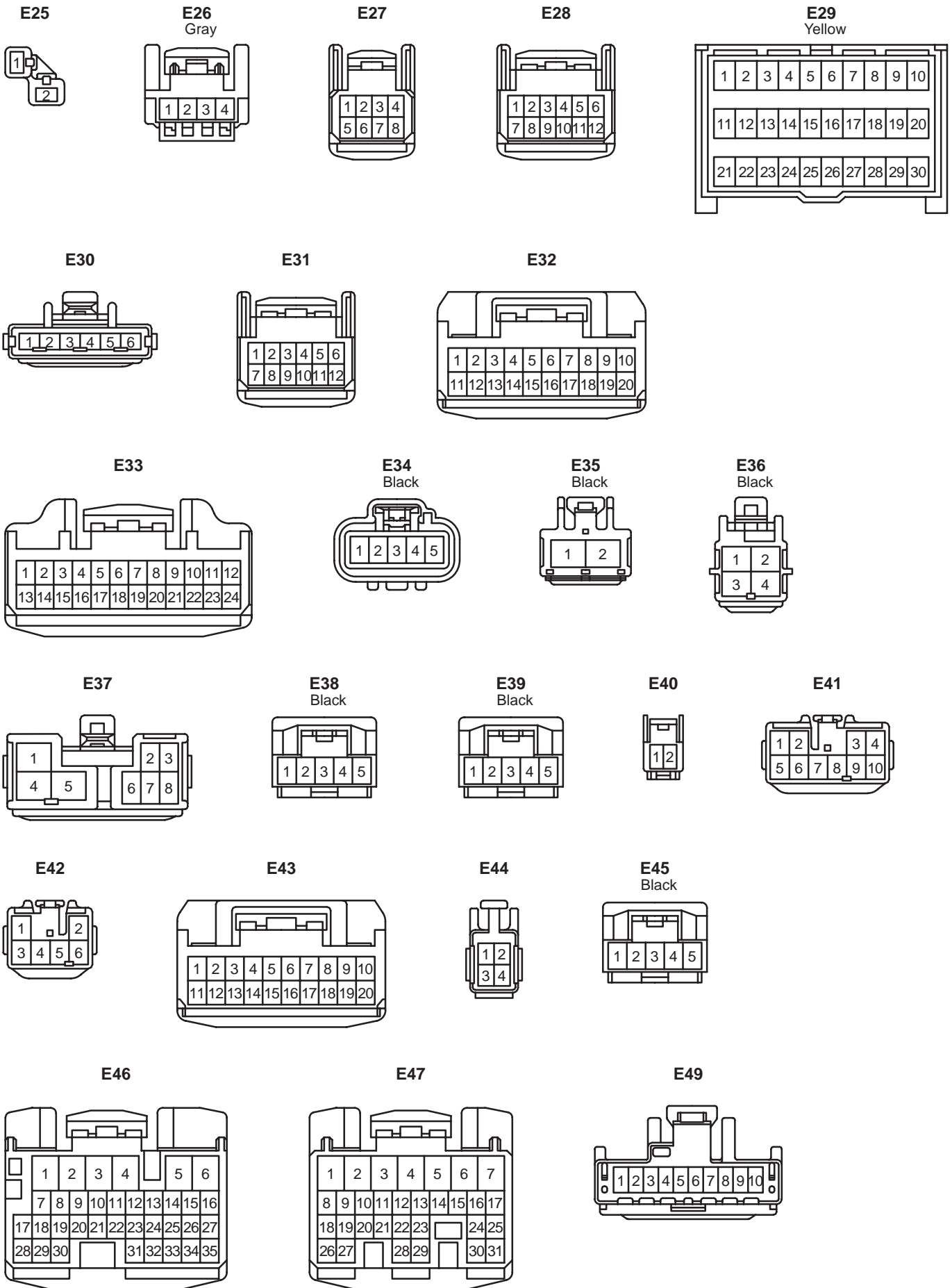

K CONNECTOR LIST

E50
Black

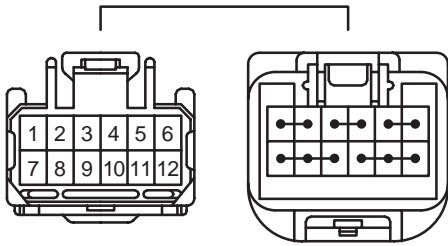

E51
Black

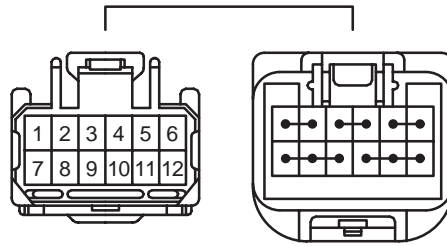

E52

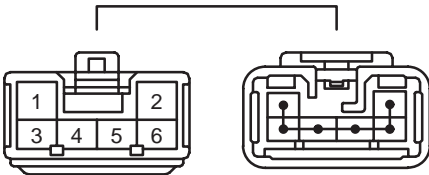

E53

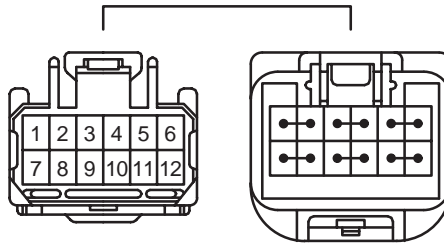

E54

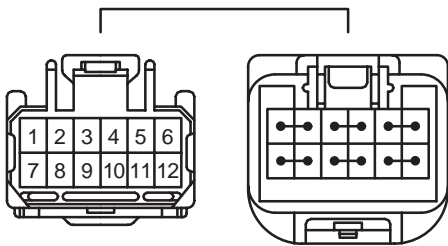

E55

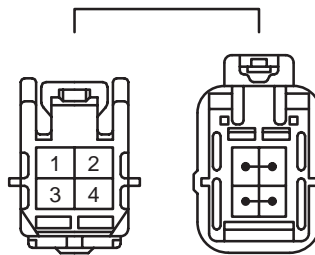

E56

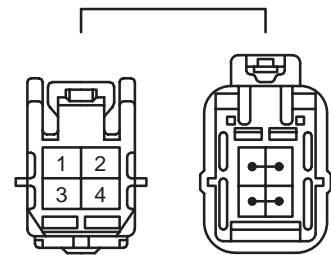

E57
Black

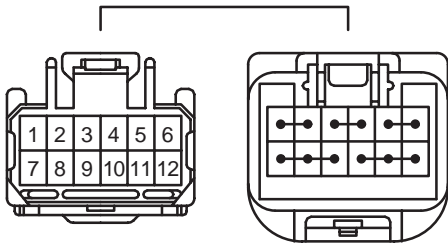

E58
Black

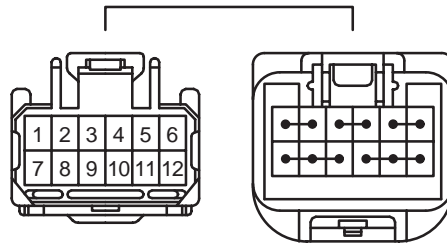

E59
Blue

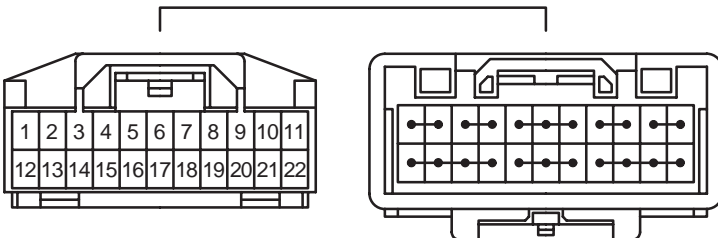

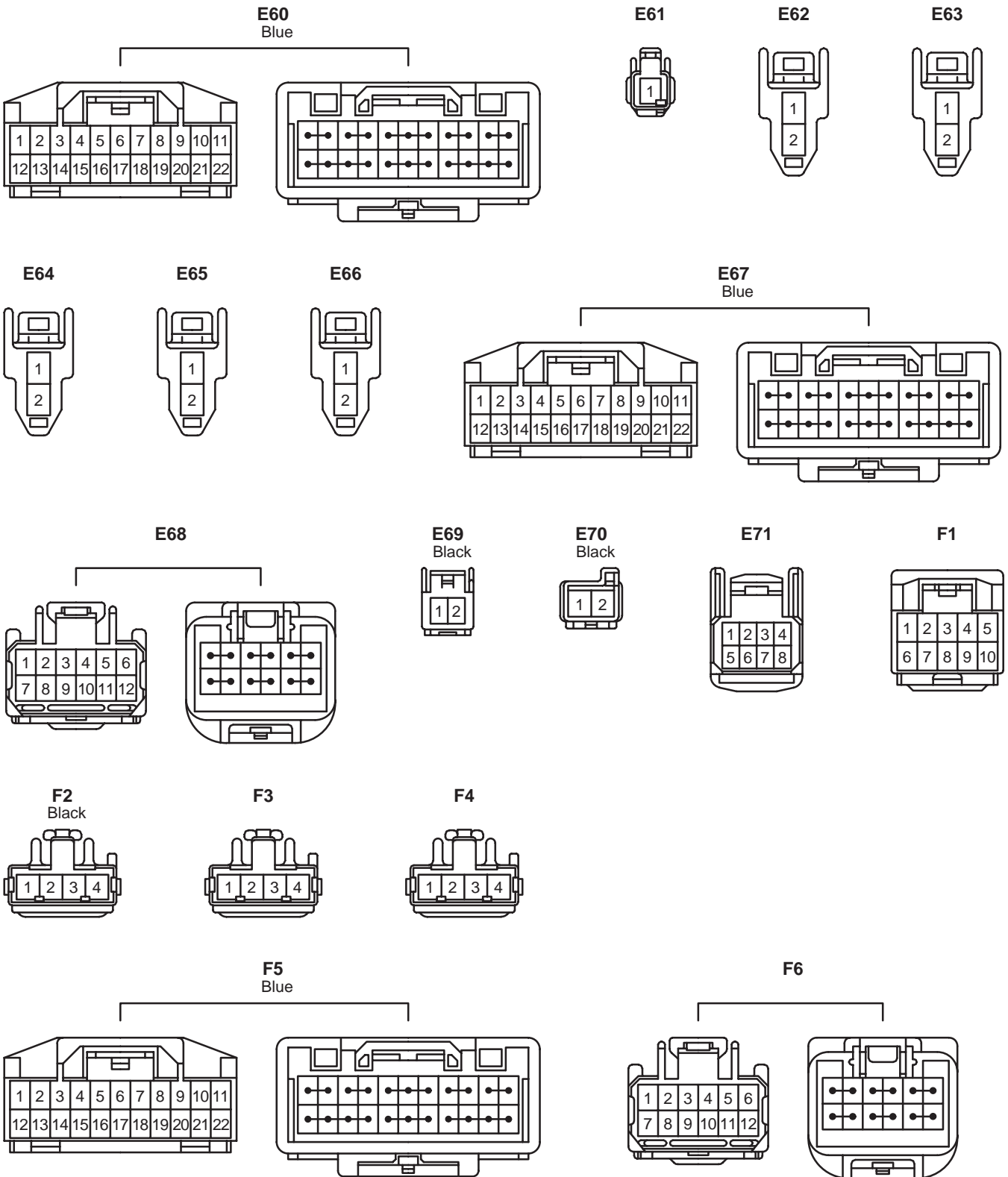

K CONNECTOR LIST

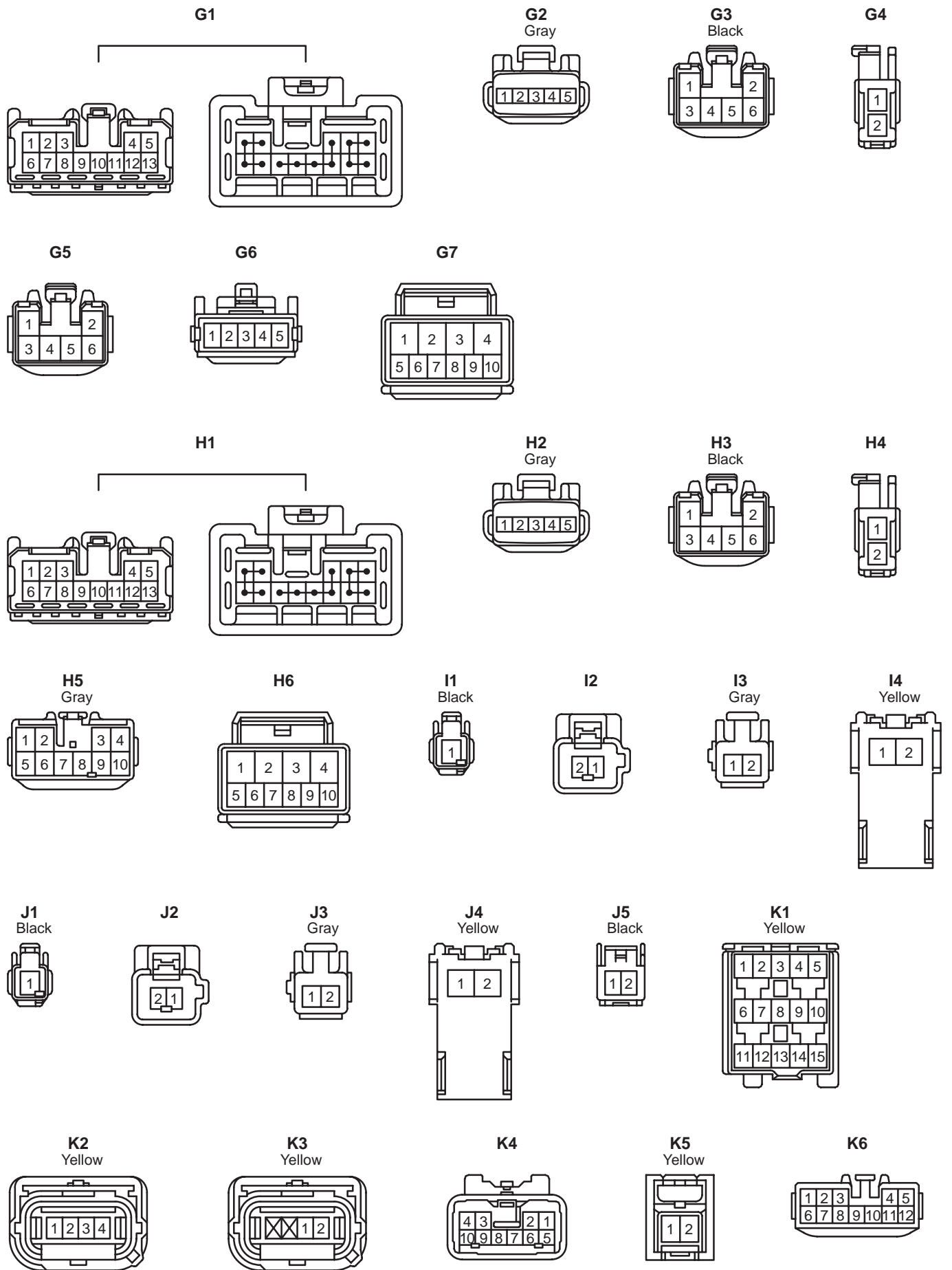

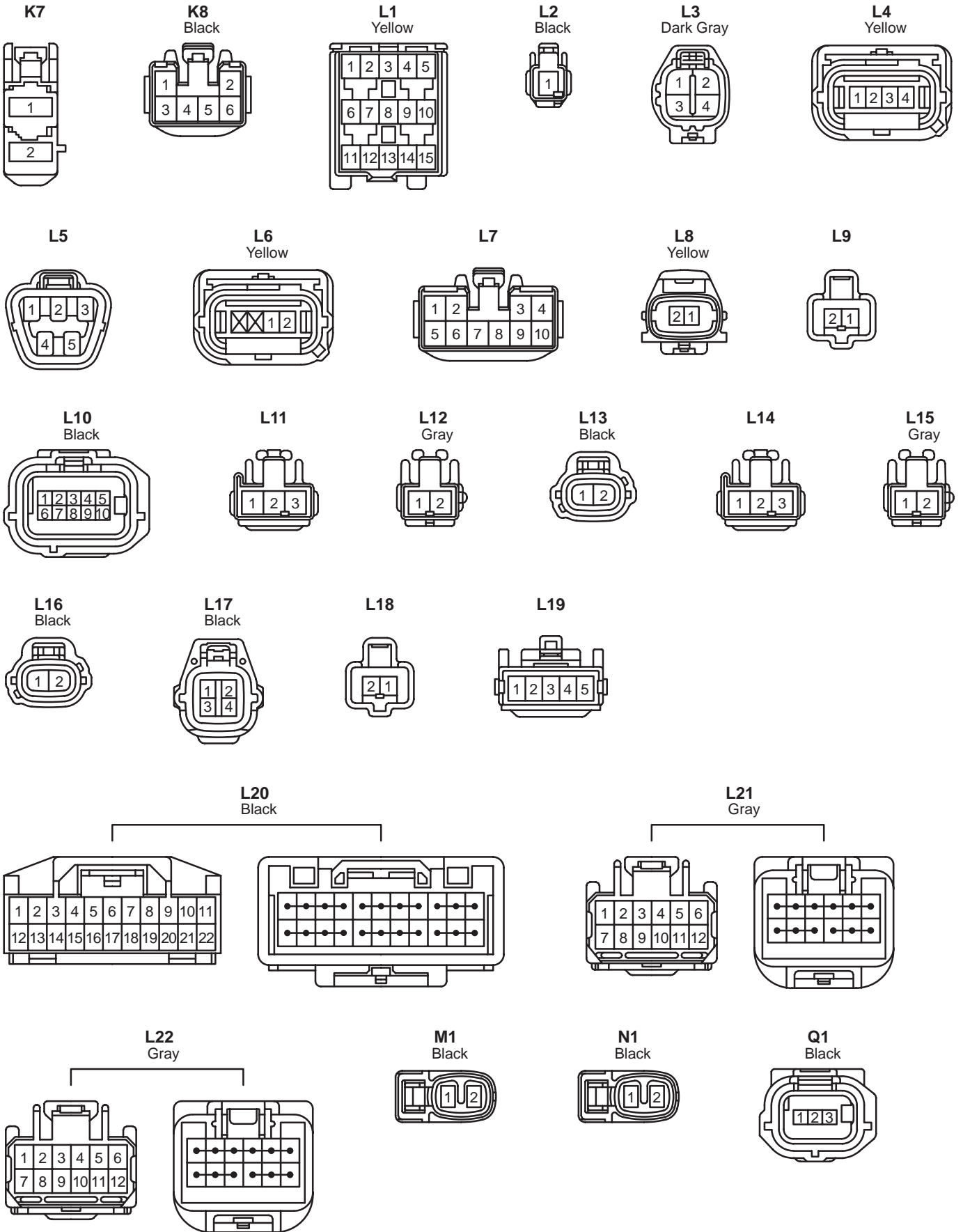

K CONNECTOR LIST

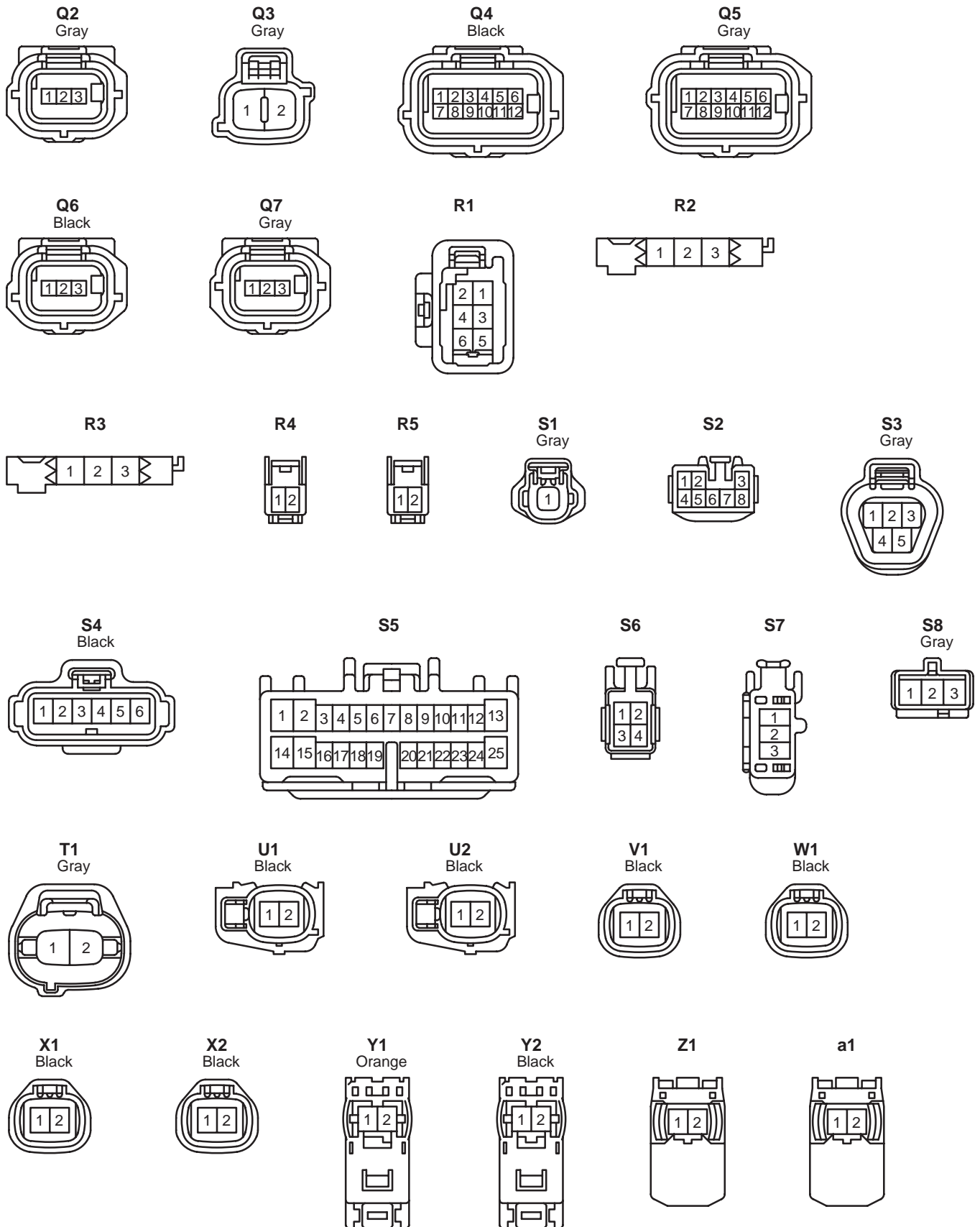

b1

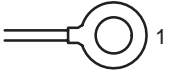

b2

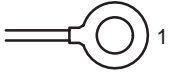

K CONNECTOR LIST

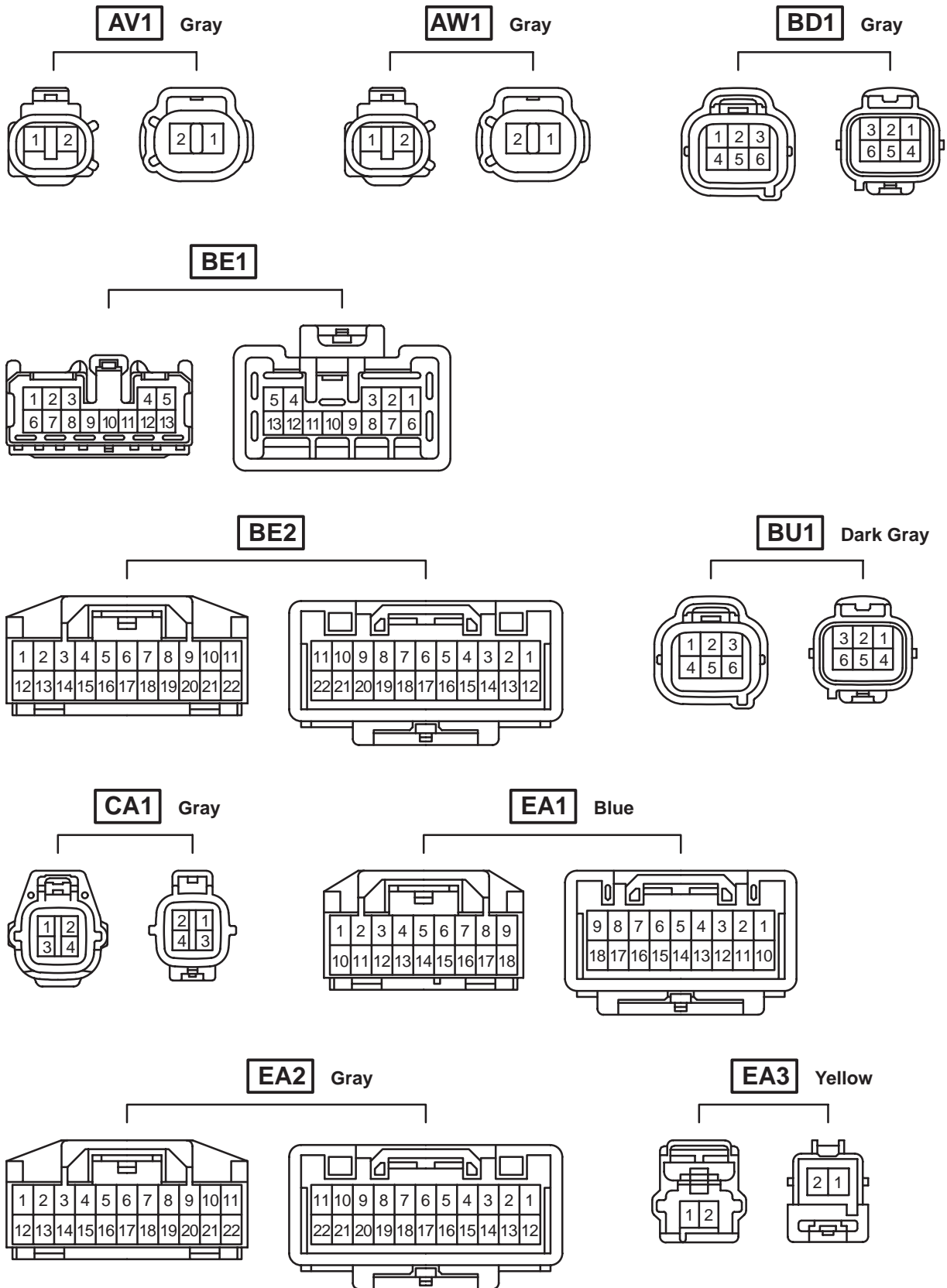

EA4

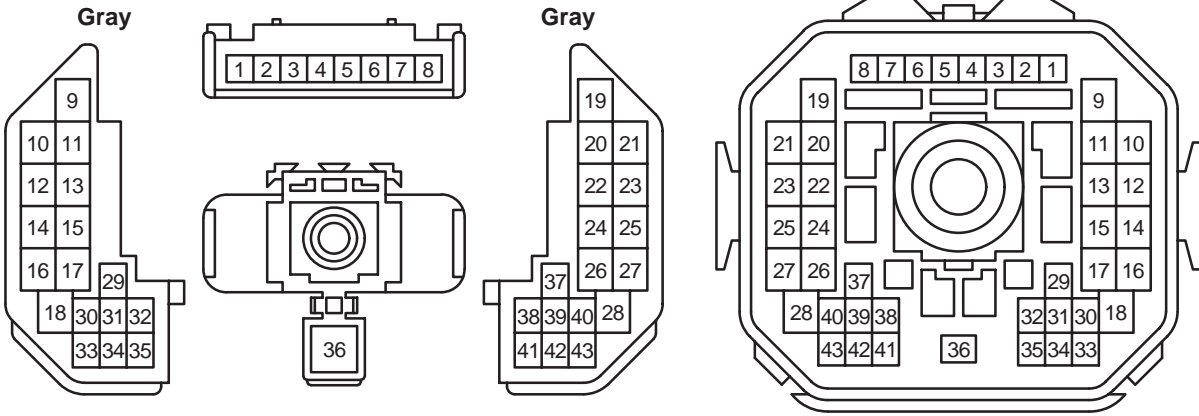

EA5 Yellow

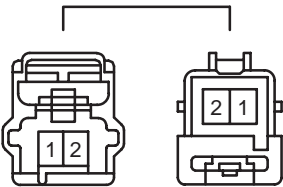

EA6 Blue

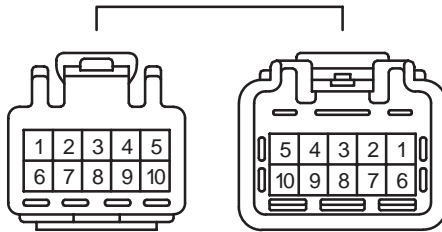

EE1

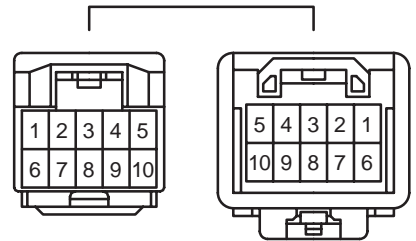

EK1

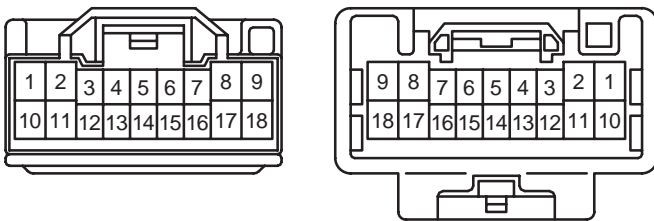

EK2 Gray

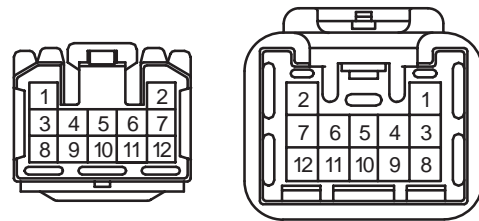

EL1

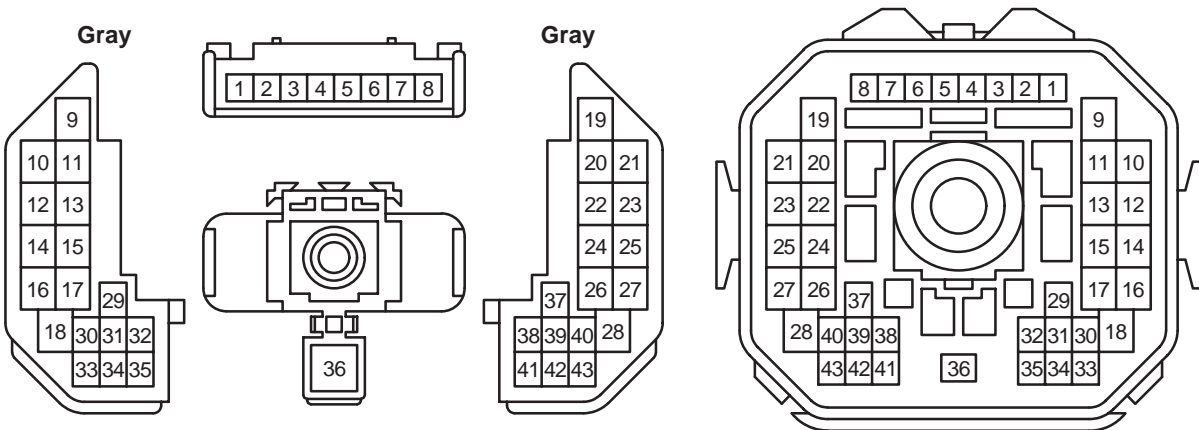

K CONNECTOR LIST

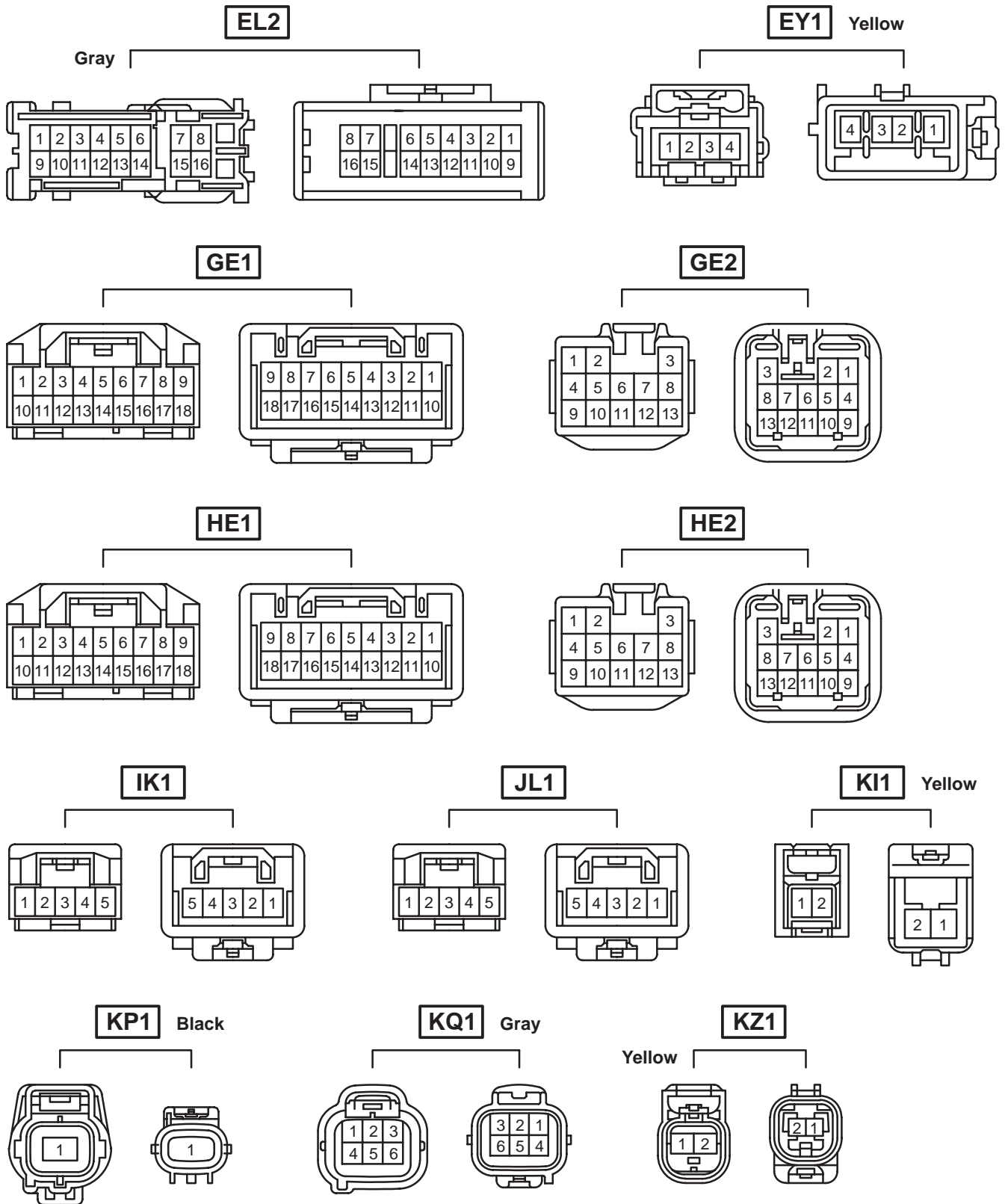

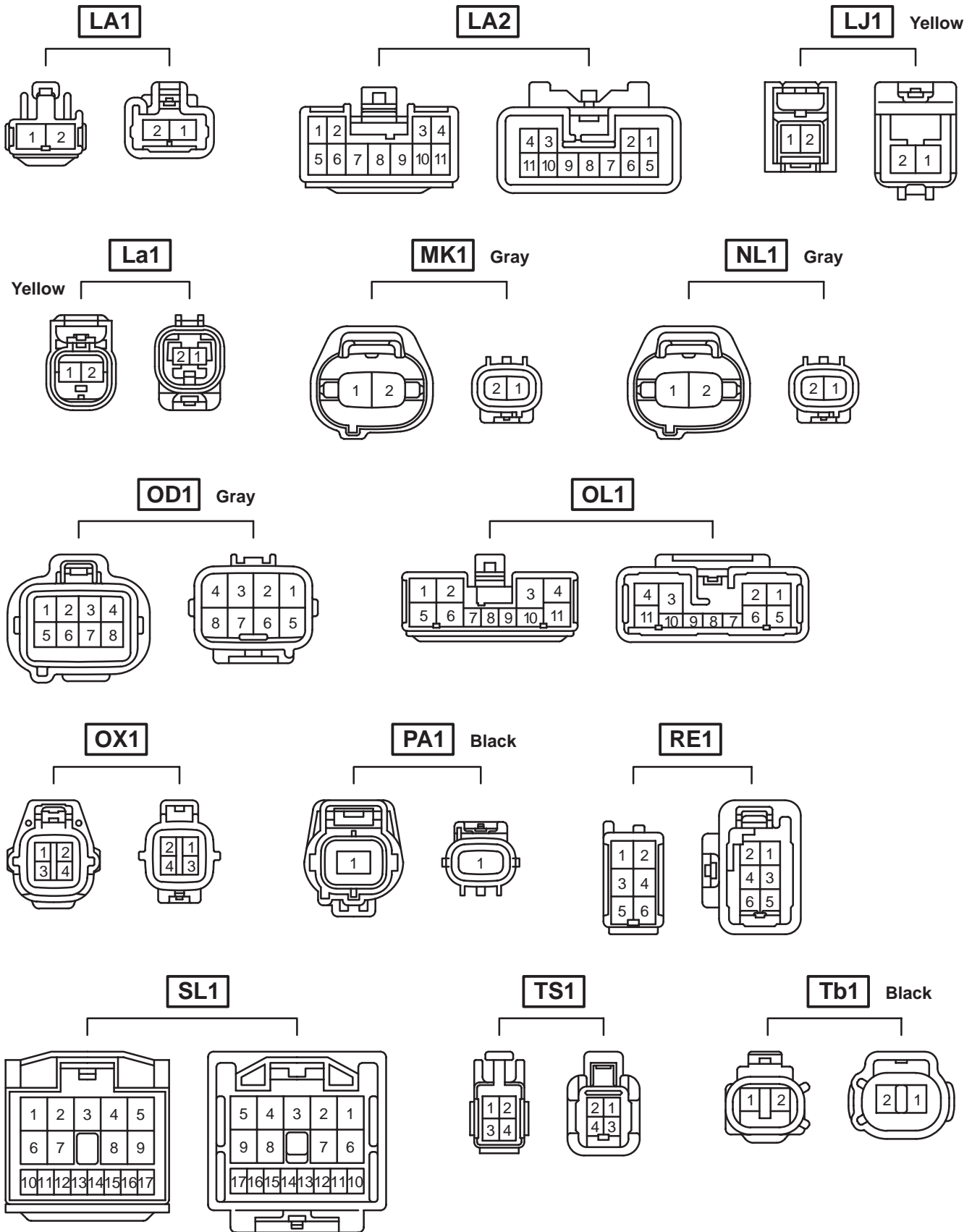

L PART NUMBER OF CONNECTORS

Code	Part Name	Part Number	Code	Part Name	Part Number
A1	Ignition SW	90980-11615	B16	Power Steering Oil Pressure SW	90980-11428
A2	Accelerator Position Sensor	90980-11858	B17	VSV (ACIS)	90980-11149
A3	Stop Lamp SW	90980-11118	B18	Fuel Injector (No.6)	90980-11875
A4	Skid Control ECU with Actuator	90980-12297	B19	Engine Coolant Temp. Sensor	90980-10735
A5	Skid Control ECU with Actuator	90980-12294	B20	Ignition Coil (No.6)	90980-11885
A6	VSC Warning Buzzer	90980-10906	B21	Fuel Injector (No.4)	90980-11875
A7	Option Connector (Towing Converter Relay)	90980-11535	B22	VSV (Purge)	90980-11156
A8	Option Connector (Driving Lamp)	90980-11156	B23	Ignition Coil (No.4)	90980-11885
A9	Clutch Start SW	90980-10825	B24	Ignition Coil (No.2)	
A10	Daytime Running Light Resistor	90980-10928	B25	Fuel Injector (No.2)	90980-11875
A11	Windshield Wiper Motor	90980-11599	B26	Camshaft Timing Oil Control Valve (LH)	90980-11162
A12	Wireless Door Lock Buzzer	90980-11142	B27	VVT Sensor (Bank 2)	90980-12353
A13	Fuel Pump Resistor	90980-10887	B28	Engine Oil Pressure SW	90980-11363
A14	Brake Fluid Level Warning SW	90980-11156	B29	Crankshaft Position Sensor	90980-12028
A15	Airbag Sensor (Front LH)	90980-11856	B30	A/C Compressor	90980-11016
A16	Turn Signal and Parking Lamp (Front LH)	90980-11020	B31	Air Fuel Ratio Sensor (Bank 2 Sensor 1)	90980-10869
A17	Horn	90980-10619	B32	Transmission Revolution Sensor (Turbine)	90980-11156
A18	Ambient Temp. Sensor	90980-11070	B33	Air Fuel Ratio Sensor (Bank 1 Sensor 1)	90980-10869
A19	Pressure SW	90980-11149	B34	Heated Oxygen Sensor (Bank 2 Sensor 2)	90980-11028
A20	Turn Signal and Parking Lamp (Front RH)	90980-11020	B35	Park/Neutral Position SW	90980-12362
A21	Windshield Washer Motor	90980-11027	B36	Heated Oxygen Sensor (Bank 1 Sensor 2)	90980-11028
A22	Airbag Sensor (Front RH)	90980-11856	B37	Electronically Controlled Transmission Solenoid	90980-12293
A23	Headlamp (LH)	90980-11314	B38	Transmission Revolution Sensor (Electronically Controlled Transmission)	90980-11156
A24	Headlamp (RH)		B39	Transfer Indicator SW (4WD Position)	
A25	Cruise Control Clutch SW	90980-10906	B40	Transfer Indicator SW (L4 Position)	
A26	Option Connector (Driving Lamp SW)	90980-11541	B41	Transfer Indicator SW (Neutral Position)	90980-10923
A27	Junction Connector	90980-11915	B42	Back-Up Lamp SW	90980-11250
A28	Junction Connector		B43	Transfer Indicator SW (Center Diff.)	90980-11156
A29	Junction Connector	90980-11661	B44	Vehicle Speed Sensor (Combination Meter)	90980-11143
A30	Junction Connector		B45	Junction Connector	90980-11542
A31	Option Connector (Horn)	90980-10619	B46	Junction Connector	90980-11915
B1	Engine Control Module	90980-12527	C1	Generator	90980-09372
B2	Engine Control Module	90980-12528	C2	Generator	90980-11964
B3	Engine Control Module	90980-12526	C3	Starter	90980-11400
B4	4WD Control ECU	90980-10997	C4	Starter	90980-09463
B5	Ignition Coil (No.5)	90980-11885	D1	ADD Actuator Assembly	90980-11858
B6	Ignition Coil (No.3)		D2	Transfer Indicator SW (Rear Diff.)	90980-11250
B7	Ignition Coil (No.1)		D3	Diff. Lock Shift Actuator Assembly	90980-11194
B8	Noise Filter (Ignition)	90980-10843	E1	Data Link Connector 3	90980-11978
B9	Fuel Injector (No.5)	90980-11875	E2	Diff. Lock SW	90980-10933
B10	Fuel Injector (No.3)		E3	Traction Control SW (Auto LSD)	
B11	Fuel Injector (No.1)		E4	Light Control Rheostat	90980-10797
B12	Camshaft Timing Oil Control Valve (RH)	90980-11162	E5	Woofer Speaker SW	90980-11013
B13	Mass Air Flow Meter	90980-11317	E6	Body ECU	90980-12562
B14	Throttle Body Assembly	90980-11858			
B15	VVT Sensor (Bank 1)	90980-12353			

Note: Not all of the above part numbers of the connector are established for the supply.

Code	Part Name	Part Number	Code	Part Name	Part Number
E7	Body ECU	90980-12560	E53	Junction Connector	90980-11661
E8	Body ECU	90980-12561	E54	Junction Connector	
E9	Turn Signal Flasher	90980-10799	E55	Junction Connector	90980-11742
E10	Clearance Warning Buzzer	90980-11142	E56	Junction Connector	
E11	Clutch Start Cancel SW	90980-12113	E57	Junction Connector	90980-11661
E12	Back Sonar SW	90980-10964	E58	Junction Connector	
E13	Combination Meter	90980-12556	E59	Junction Connector	90980-11915
E14	Combination Meter	90980-12554	E60	Junction Connector	
E15	Traction Control SW (Active TRAC)	90980-11013	E61	Junction Connector	90980-10871
E16	Steering Sensor	90980-12553	E62	Junction Connector	90980-12355
E17	Spiral Cable	90980-12552	E63	Junction Connector	
E18	Airbag Squib (Steering Wheel Pad)	90980-12160	E64	Junction Connector	
E19	Windshield Wiper SW Assembly	90980-11594	E65	Junction Connector	
E20	Headlamp Dimmer SW Assembly	90980-11672	E66	Junction Connector	
E21	Unlock Warning SW	90980-10794	E67	Junction Connector	
E22	Parking Brake SW	90980-10871	E68	Junction Connector	90980-11661
E23	Door Control Receiver	90980-11909	E69	A/T Shift Lever Illumination	90980-12063
E24	Main SW	90980-10964	E70	Option Connector (Off-road Lamp Diode)	90980-10962
E25	Power Outlet Socket	90980-10760	E71	Noise Filter (Stereo Jack Adapter)	90980-12551
E26	Stereo Jack Adapter	82824-21030	F1	Accessory Meter	90980-11923
E27	Speaker Condenser	90980-12551	F2	Clock	90980-11013
E28	Shift Lock Control ECU	90980-12552	F3	Tweeter (Front RH)	
E29	Airbag Sensor Assembly Center	90980-12710	F4	Tweeter (Front LH)	90980-11915
E30	Option Connector (Off-road Lamp SW)	90980-10933	F5	Junction Connector	
E31	Clearance Warning ECU	90980-12552	F6	Junction Connector	90980-11661
E32	A/C Amplifier	90980-12460	G1	Junction Connector	90980-11542
E33	A/C Amplifier	90980-12554	G2	Outer Rear View Mirror (RH)	90980-11182
E34	Yaw Rate Sensor	90980-11904	G3	Power Window Regulator Motor (Front RH)	90980-10797
E35	Blower Motor	90980-11579	G4	Speaker (Front RH)	90980-10935
E36	Blower Resistor	90980-11136	G5	Door Lock Control SW	90980-10797
E37	Blower SW	90980-10877	G6	Power Window SW (Front RH)	90980-10789
E38	Damper Servo Motor (Air Mix)	90980-11909	G7	Door Lock Assembly (Front RH)	90980-12226
E39	Damper Servo Motor (Air Vent Mode)		H1	Junction Connector	90980-11542
E40	A/C Thermistor	90980-11918	H2	Outer Rear View Mirror (LH)	90980-11182
E41	Radio Receiver Assembly	90980-10997	H3	Power Window Regulator Motor (Front LH)	90980-10797
E42	Radio Receiver Assembly	90980-10996	H4	Speaker (Front LH)	90980-10935
E43	Radio Receiver Assembly	90980-12460	H5	Power Window Master SW	90980-10997
E44	Option Connector (TVIP)	90980-10795	H6	Door Lock Assembly (Front LH)	90980-12226
E45	Damper Servo Motor (Air Inlet)	90980-11909	I1	Door Courtesy SW (Front RH)	90980-10871
E46	Engine Control Module	90980-12529	I2	Door Courtesy SW (Rear RH Upper Side)	90980-10824
E47	Engine Control Module	90980-12525	I3	Door Courtesy SW (Rear RH Lower Side)	90980-10825
E49	Outer Mirror SW	90980-11657	I4	Pretensioner (RH)	90980-12253
E50	Junction Connector	90980-11661	J1	Door Courtesy SW (Front LH)	90980-10871
E51	Junction Connector		J2	Door Courtesy SW (Rear LH Upper Side)	90980-10824
E52	Junction Connector	90980-10976	J3	Door Courtesy SW (Rear LH Lower Side)	90980-10825

L PART NUMBER OF CONNECTORS

Code	Part Name	Part Number	Code	Part Name	Part Number
J4	Pretensioner (LH)	90980-12253	Q2	Occupant Classification Sensor (Rear LH)	90980-12354
J5	Front Seat Outer Belt (LH)	90980-12063	Q3	Front Seat Inner Belt (RH)	90980-11019
K1	Airbag Sensor Assembly Center	90980-12450	Q4	Occupant Classification ECU	90980-12356
K2	Side Airbag Sensor (Front RH)	90980-12225	Q5	Occupant Classification ECU	90980-12357
K3	Side Airbag Sensor (Rear RH)	90980-12352	Q6	Occupant Classification Sensor (Rear RH)	90980-12353
K4	Speaker (Woofer w/ Amplifier)	90980-11102	Q7	Occupant Classification Sensor (Front RH)	90980-12354
K5	Curtain Shield Airbag Squib (RH)	90980-11886	R1	Option Connector (EC Mirror and Off-road Lamp)	90980-11452
K6	Voltage Inverter	90980-10803	R2	Room Lamp (Front)	-
K7	Voltage Inverter	90980-12299	R3	Room Lamp (Rear)	
K8	Power Outlet Socket (115V)	90980-10797	R4	Speaker (Roof LH)	
L1	Airbag Sensor Assembly Center	90980-12449	R5	Speaker (Roof RH)	
L2	Door Courtesy SW (Back Door)	90980-10871	S1	License Plate Lamp	90980-11166
L3	Option Connector (Trailer Socket)	90980-11028	S2	Door ECU (Back)	90980-10799
L4	Side Airbag Sensor (Front LH)	90980-12225	S3	Rear Wiper Motor Assembly	90980-11599
L5	Fuel Suction Pump and Gage Assembly	90980-11077	S4	Back Door Lock Assembly	90980-11858
L6	Side Airbag Sensor (Rear LH)	90980-12352	S5	Door ECU (Back)	90980-11877
L7	4WD Control ECU (Rear Diff. Lock)	90980-10801	S6	Back Window Lock Assembly	90980-10795
L8	Curtain Shield Airbag Squib (LH)	90980-10886	S7	Back Door Lock Cylinder Assembly	90980-11490
L9	Tweeter (Rear LH)	90980-11060	S8	Diode (Back Door)	90980-11071
L10	Canister Pump Module	90980-12380	T1	Center Stop Lamp	90980-11156
L11	Rear Combination Lamp (LH)	90980-10908	U1	Knock Control Sensor (Bank 2)	90980-11875
L12	Rear Combination Lamp (LH)	90980-10906	U2	Knock Control Sensor (Bank 1)	
L13	Rear Combination Lamp (LH)	90980-11162	V1	Speed Sensor (Front RH)	90980-11900
L14	Rear Combination Lamp (RH)	90980-10908	W1	Speed Sensor (Front LH)	
L15	Rear Combination Lamp (RH)	90980-10906	X1	Speed Sensor (Rear RH)	
L16	Rear Combination Lamp (RH)	90980-11162	X2	Speed Sensor (Rear LH)	
L17	Front Seat Inner Belt (LH)	90980-10942	Y1	Airbag Squib (Front Passenger's Airbag Assembly)	90980-12224
L18	Tweeter (Rear RH)	90980-11060	Y2	Airbag Squib (Front Passenger's Airbag Assembly)	90980-12219
L19	Front Seat Inner Belt (LH)	90980-10789	Z1	Side Airbag Squib (RH)	90980-12452
L20	Junction Connector	90980-11915	a1	Side Airbag Squib (LH)	
L21	Junction Connector	90980-11661	b1	Rear Window Defogger	90980-09023
L22	Junction Connector		b2	Rear Window Defogger	
M1	Ultrasonic Sensor (Rear Center RH)	90980-11246			
N1	Ultrasonic Sensor (Rear Center LH)				
Q1	Occupant Classification Sensor (Front LH)	90980-12353			

Note: Not all of the above part numbers of the connector are established for the supply.

HOW TO READ THIS SECTION

* The system shown here is an EXAMPLE ONLY. It is different to the actual circuit shown in the wiring diagram section.

FJ CRUISER (EM0240U)

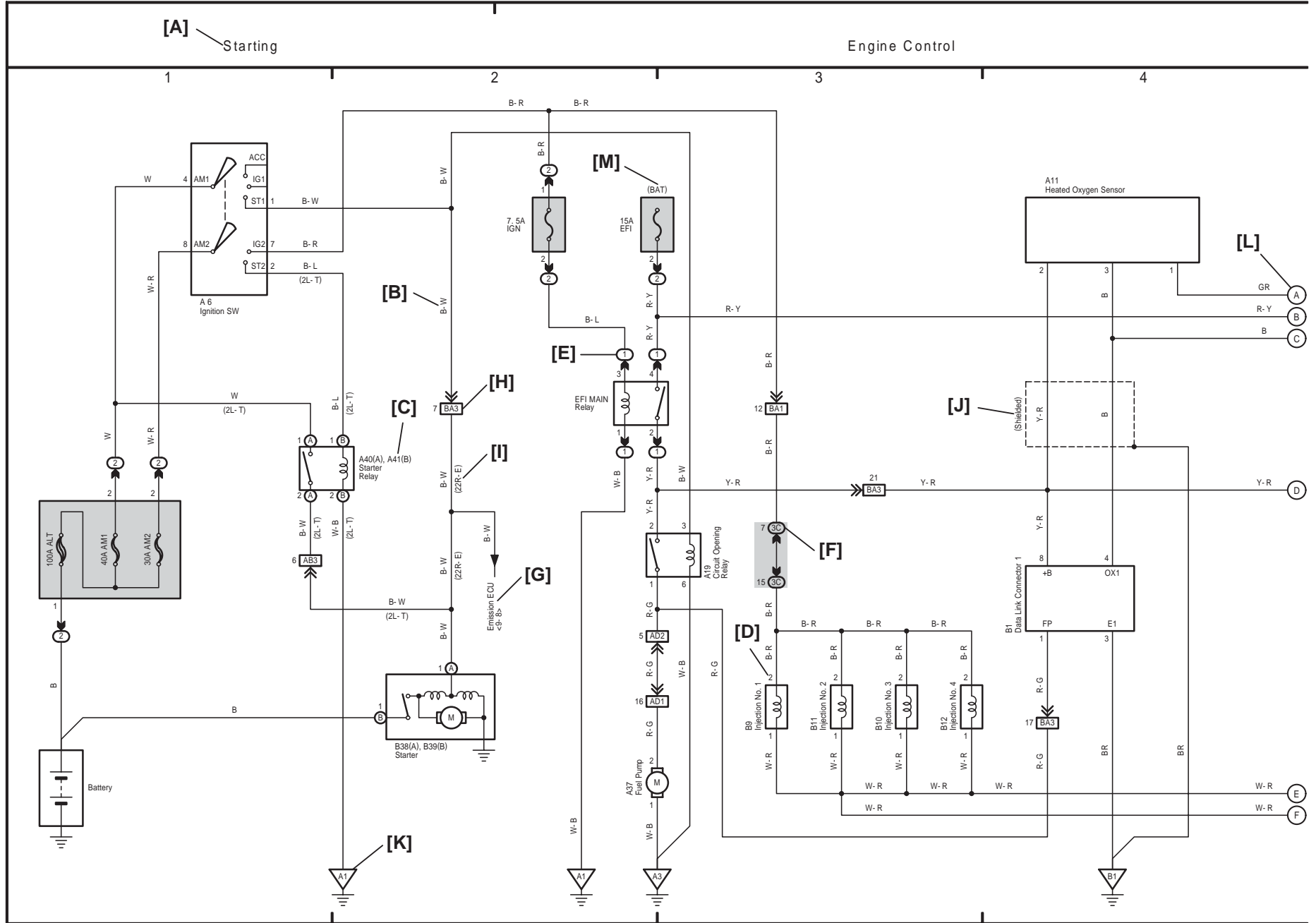

M OVERALL ELECTRICAL WIRING DIAGRAM

[A] : System Title

[B] : Indicates the wiring color.

Wire colors are indicated by an alphabetical code.

- | | | |
|------------|------------|------------------|
| B = Black | W = White | BR = Brown |
| L = Blue | V = Violet | SB = Sky Blue |
| R = Red | G = Green | LG = Light Green |
| P = Pink | Y = Yellow | GR = Gray |
| O = Orange | | |

The first letter indicates the basic wire color and the second letter indicates the color of the stripe.

Example: L - Y

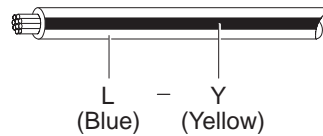

[C] : The position of the parts is the same as shown in the wiring diagram and wire routing.

[D] : Indicates the pin number of the connector. The numbering system is different for female and male connectors.

Example: Numbered in order from upper left to lower right

Numbered in order from upper right to lower left

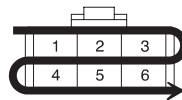

Female

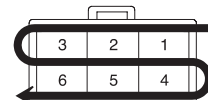

Male

The numbering system for the overall wiring diagram is the same as above

[E] : Indicates a Relay Block. No shading is used and only the Relay Block No. is shown to distinguish it from the J/B.

Example:  Indicates Relay Block No.1

[F] : Junction Block (The number in the circle is the J/B No. and the connector code is shown beside it). Junction Blocks are shaded to clearly separate them from other parts.

Example:

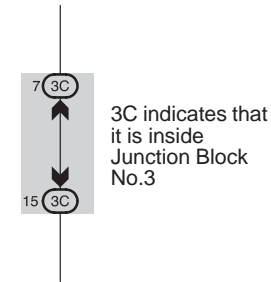

[G] : Indicates related system.

[H] : Indicates the wiring harness and wiring harness connector. The wiring harness with male terminal is shown with arrows (↘). Outside numerals are pin numbers.

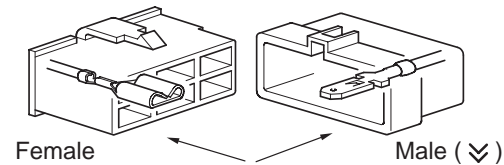

Female

Male (↘)

[I] : () is used to indicate different wiring and connector, etc. when the vehicle model, engine type, or specification is different.

[J] : Indicates a shielded cable.



[K] : Indicates a ground point.

[L] : The same code occurring on the next page indicates that the wire harness is continuous.

[M] : Indicates the ignition key position(s) when the power is supplied to the fuse(s).

SYSTEM INDEX

SYSTEMS	LOCATION	SYSTEMS	LOCATION
ABS	13-1	* Option Connector (Off-road Lamp)	
Accessory Meter	21-3	* Option Connector (TVIP)	
Air Conditioning	25-1	* Power Window	
Audio System	23-1	* Rear Window Defogger	
Auto LSD	13-1	* Rear Wiper and Washer	
Back-Up Light	12-1	* Seat Belt Warning	
Charging	4-1	* Wireless Door Lock Control	
Clock	21-1	Multiplex Communication System (CAN)	7-1
Combination Meter	24-1	Option Connector (Automatic Glare-Resistant EC Mirror)	26-3
Cruise Control	5-17	Option Connector (Trailer Towing)	26-1
Data Link Connector 3	6-1	Power Outlet (115V)	20-1
Electric Tension Reducer	18-3	Power Outlet (12V)	20-4
Electronically Controlled Transmission and A/T Indicator	5-14	Power Source	1-1
Engine Control	5-1	Rear Differential Lock	15-1
Front Wiper and Washer	17-1	Remote Control Mirror	19-1
Horn	18-1	Shift Lock	19-3
Ignition	3-1	SRS	16-1
Illumination	10-1	Starting	2-1
Multiplex Communication System (BEAN)	8-1	Stop Light	11-1
* Door Lock Control		Taillight	10-1
* Headlight		TOYOTA Parking Assist (Clearance Sonar)	22-1
* Interior Light		TRAC	13-1
* Key Reminder		Turn Signal and Hazard Warning Light	9-1
* Light Auto Turn Off System		VSC	13-1
* Option Connector (Driving Lamp)		4WD	14-1

1 FJ CRUISER

Power Source

* 1 : w/ Daytime Running Light
 * 2 : w/o Daytime Running Light

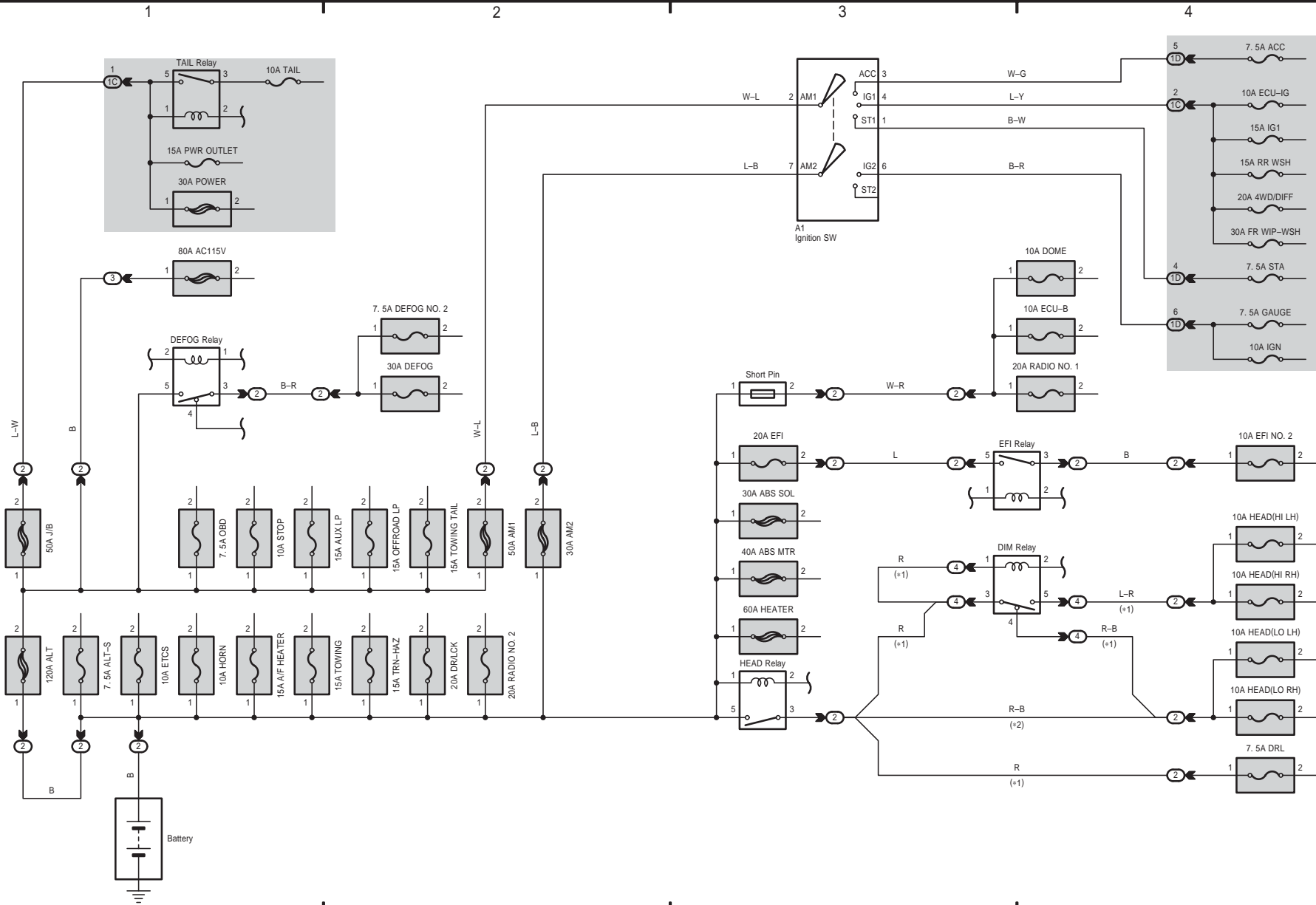

FJ CRUISER (EM0240U)



Starting

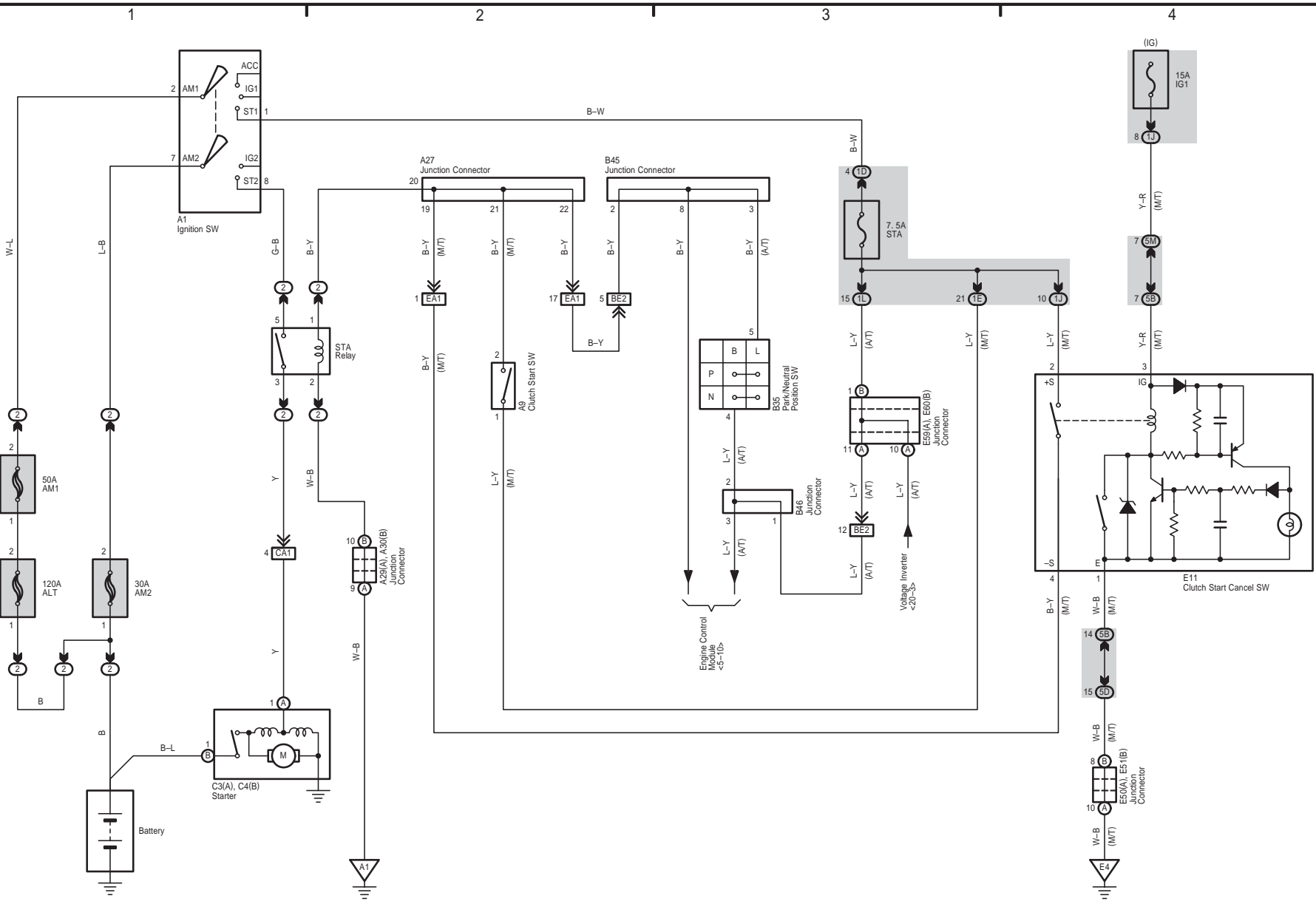

3 FJ CRUISER

Ignition

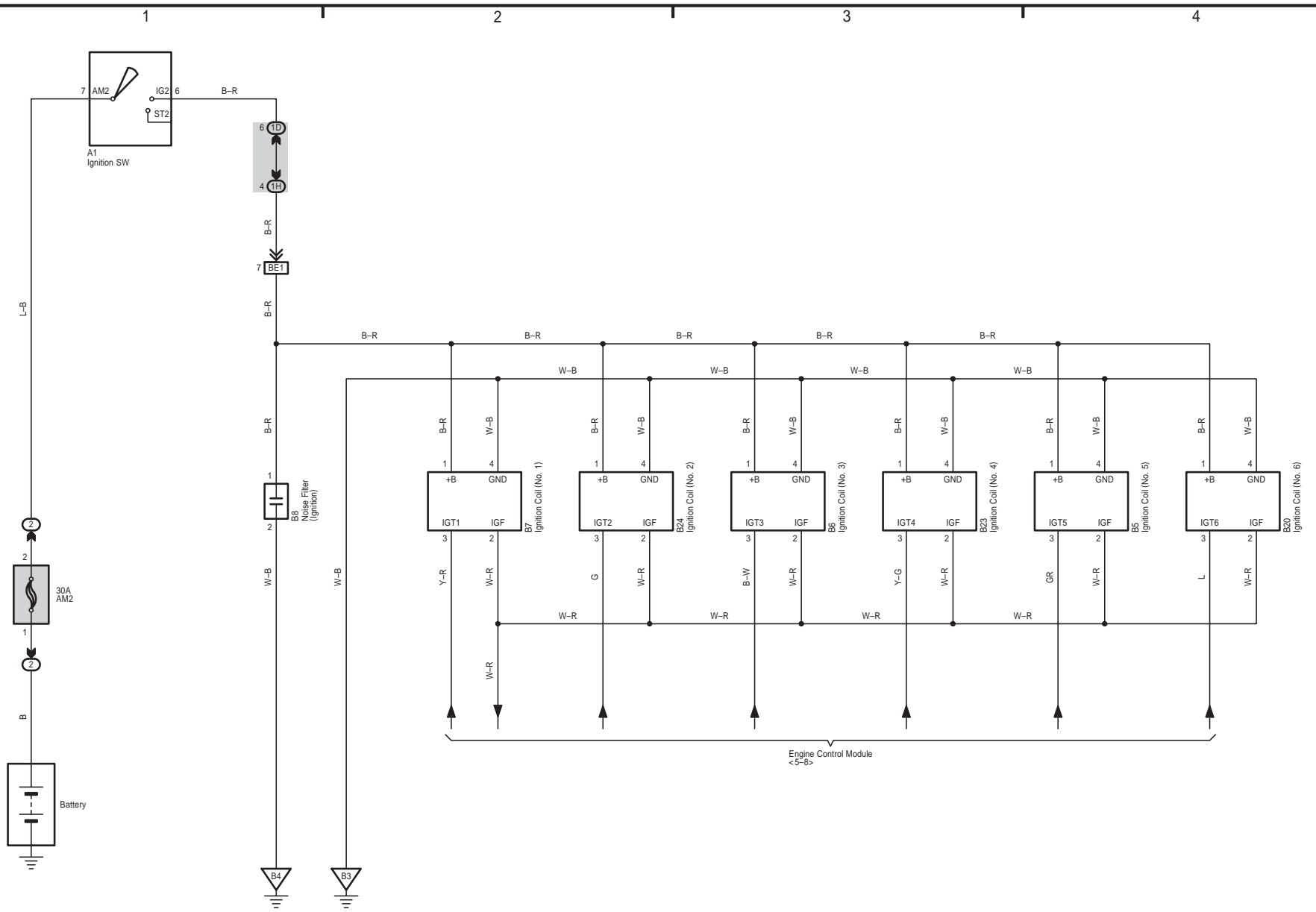

FJ CRUISER (EM0240U)



4 FJ CRUISER

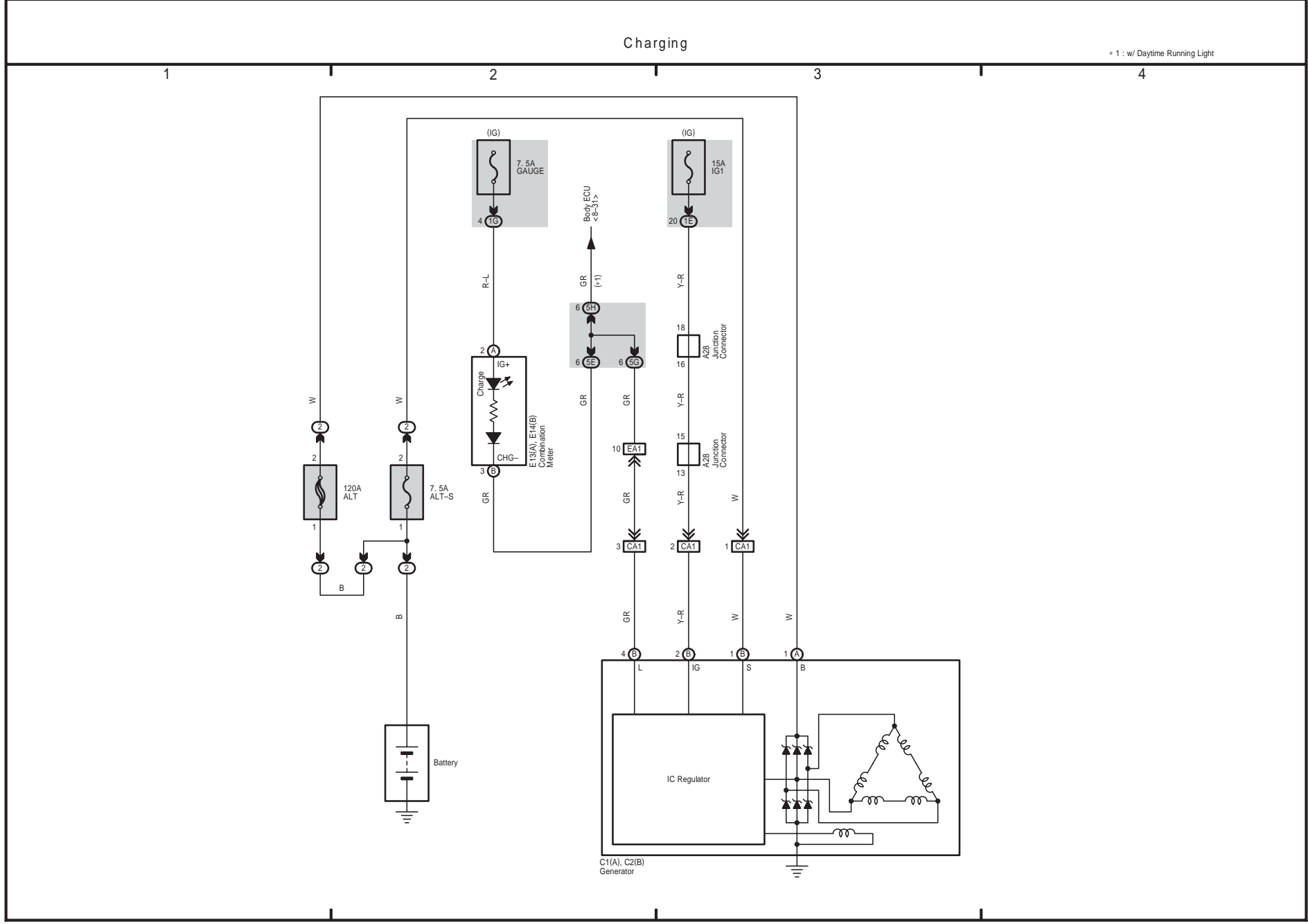

5 FJ CRUISER

(Cont. next page)

OVERALL ELECTRICAL WIRING DIAGRAM

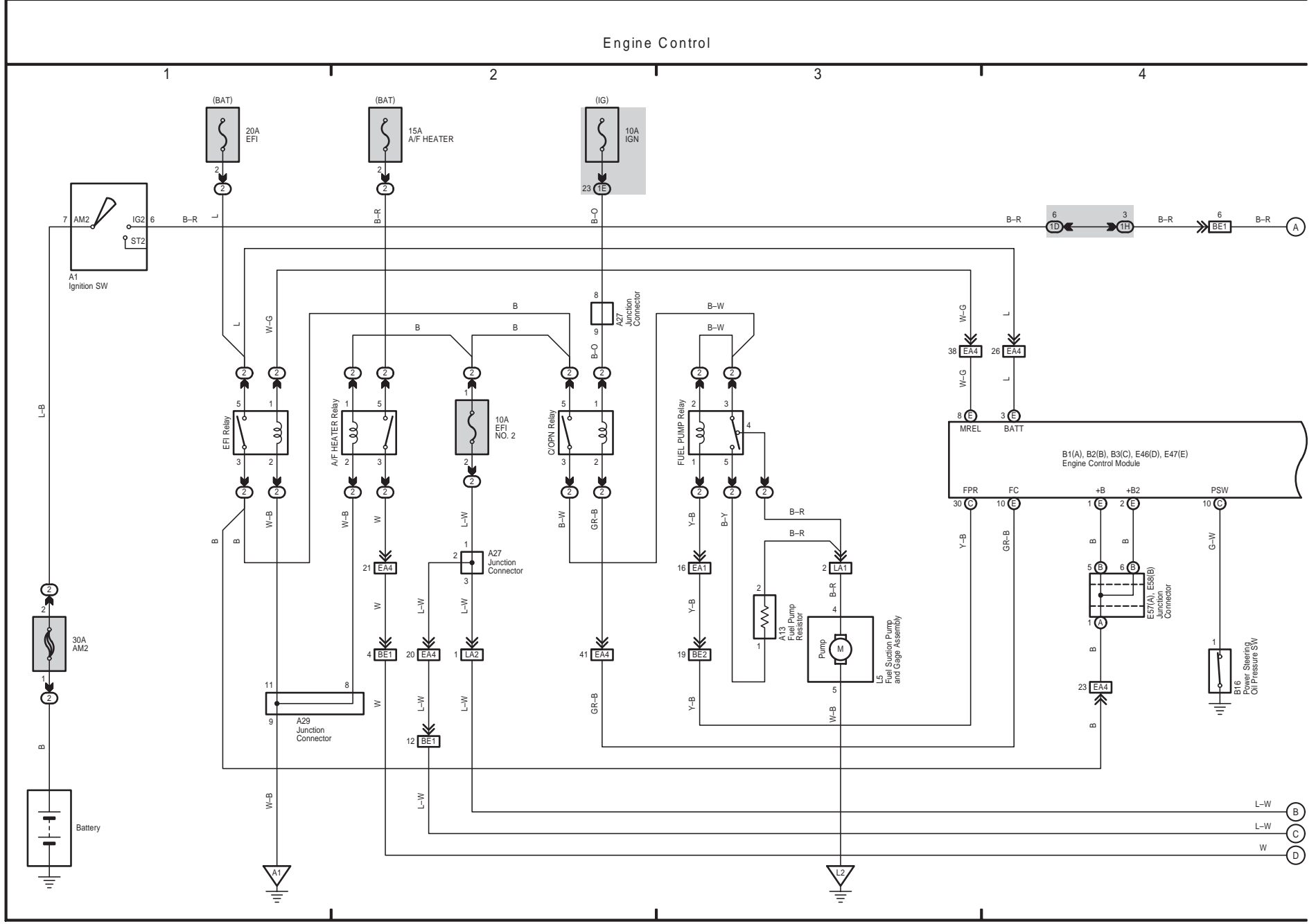

Engine Control

* 1 : Shielded

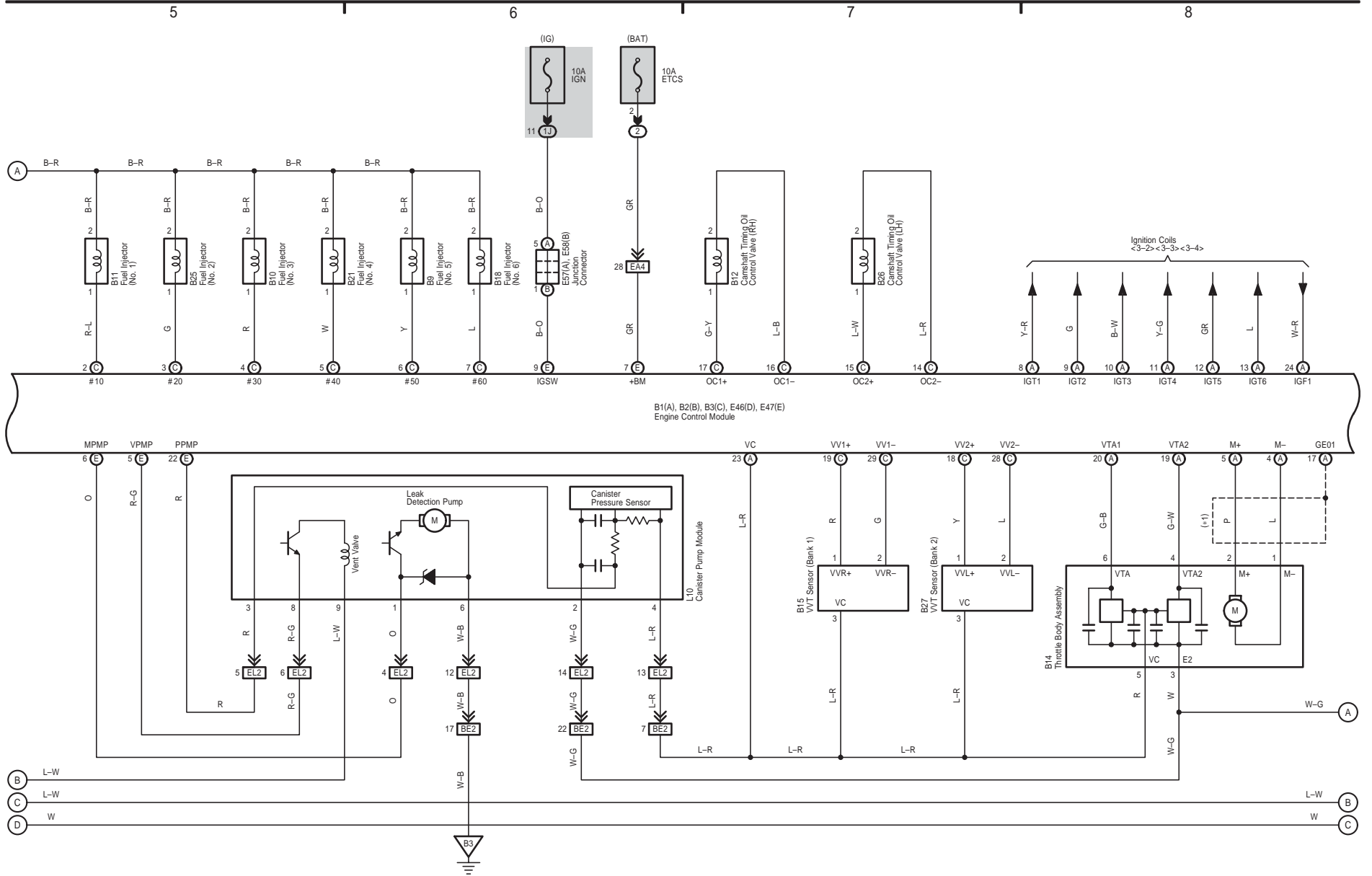

Engine Control

* 1 : Shielded

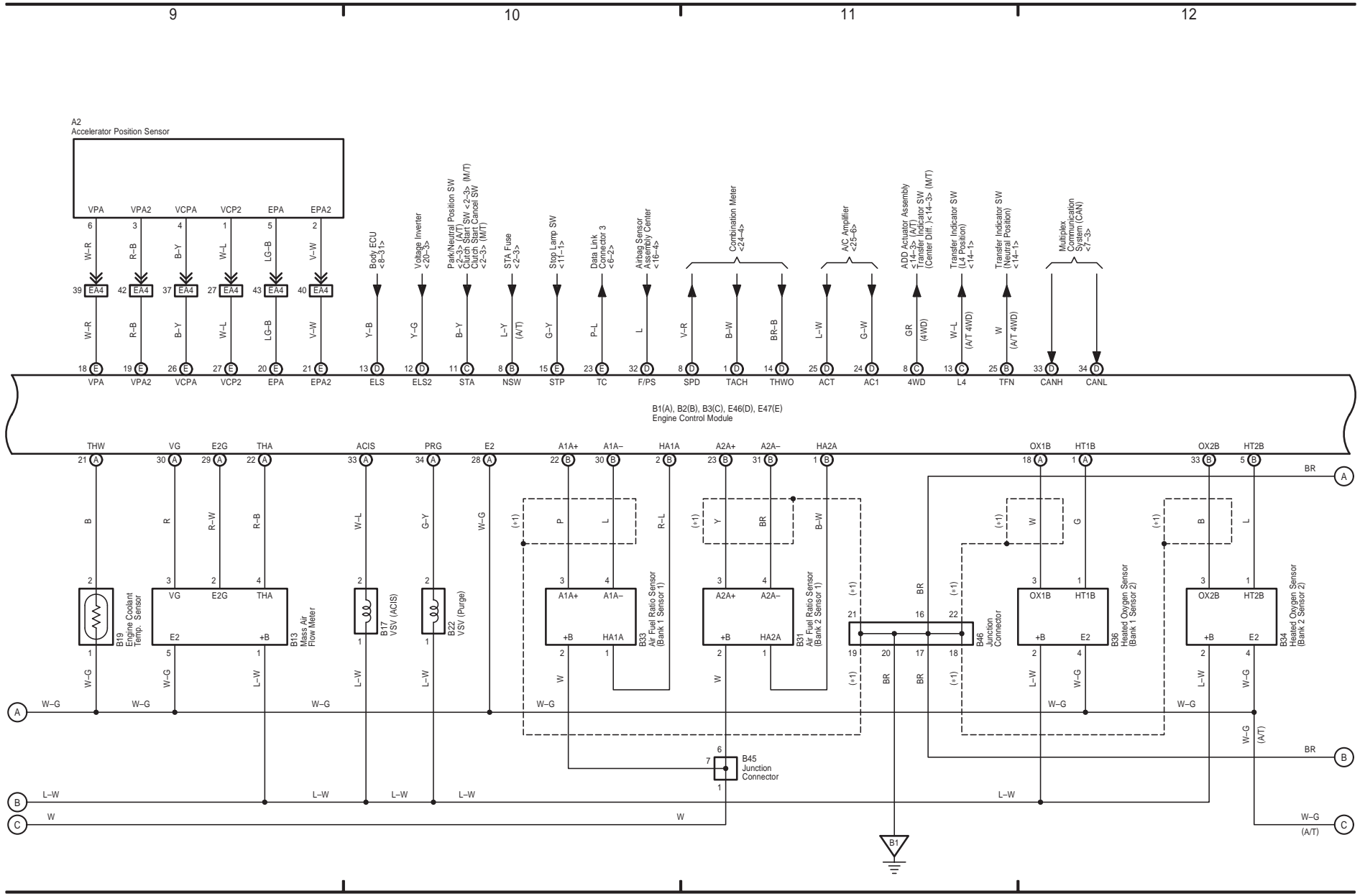

Engine Control

Electronically Controlled Transmission and A/T Indicator

13

14

15

16

* 1 : Shielded

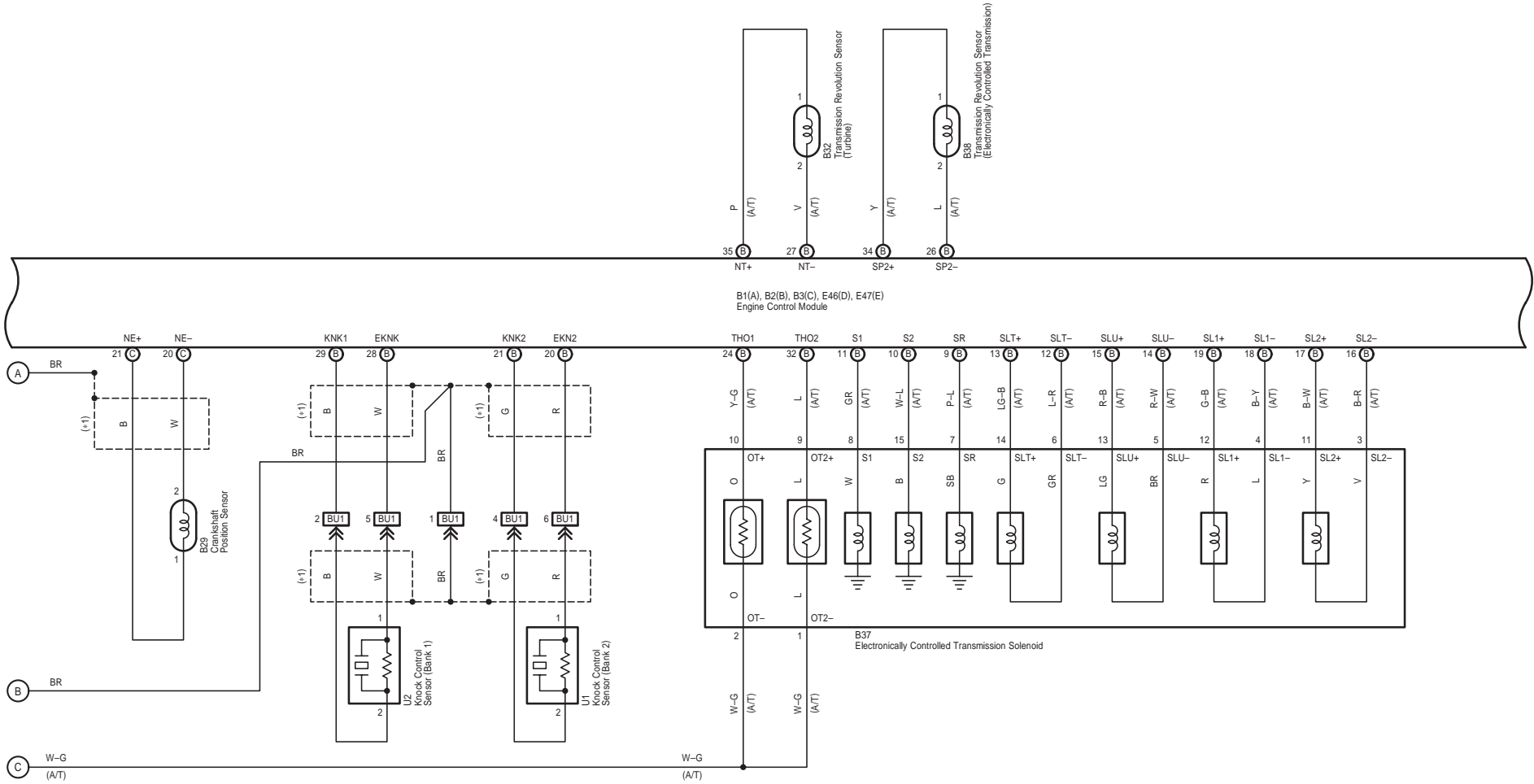

Cruise Control

* 2 : w/ Cruise Control

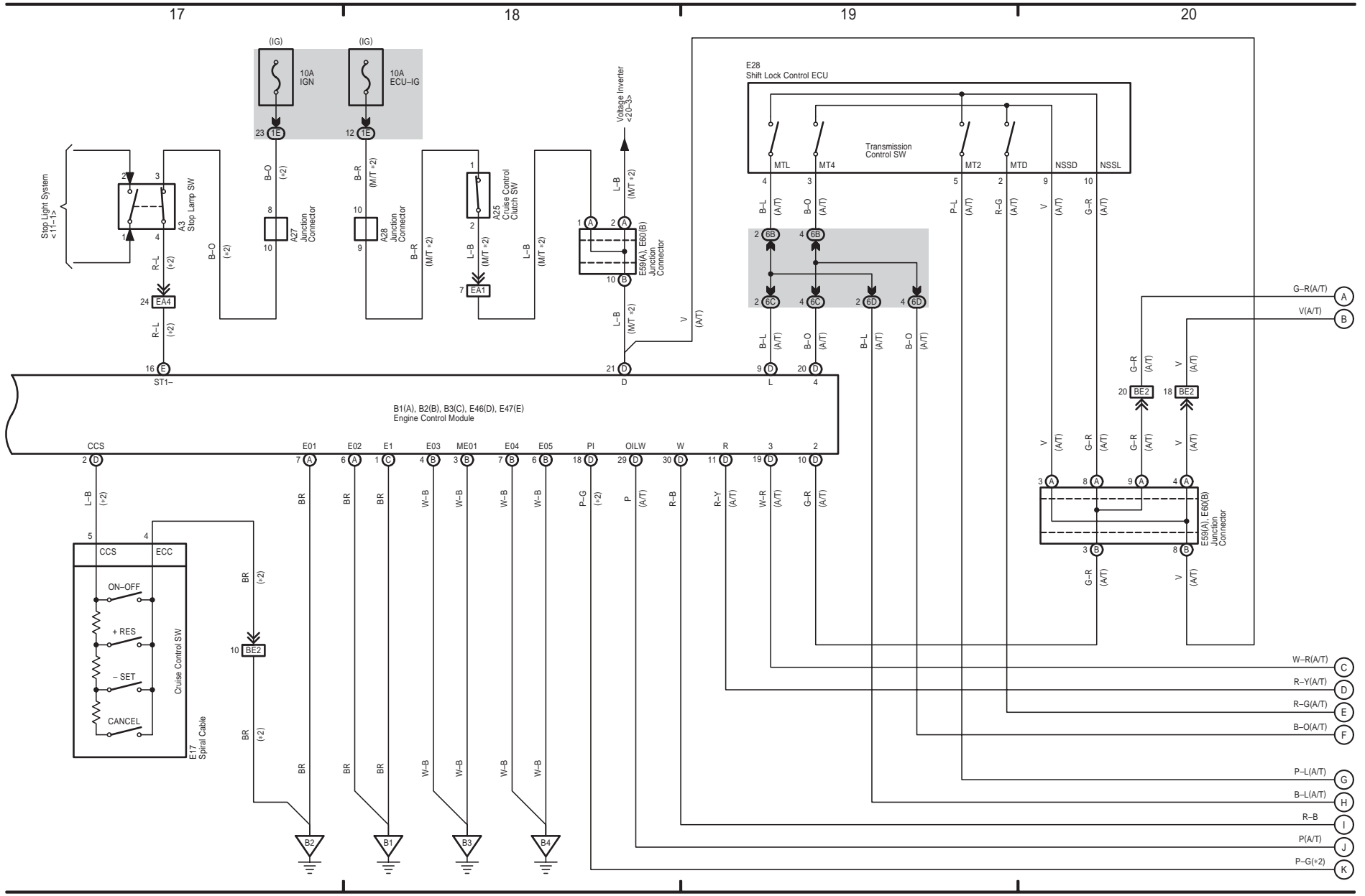

Cruise Control

* 2 : w/ Cruise Control

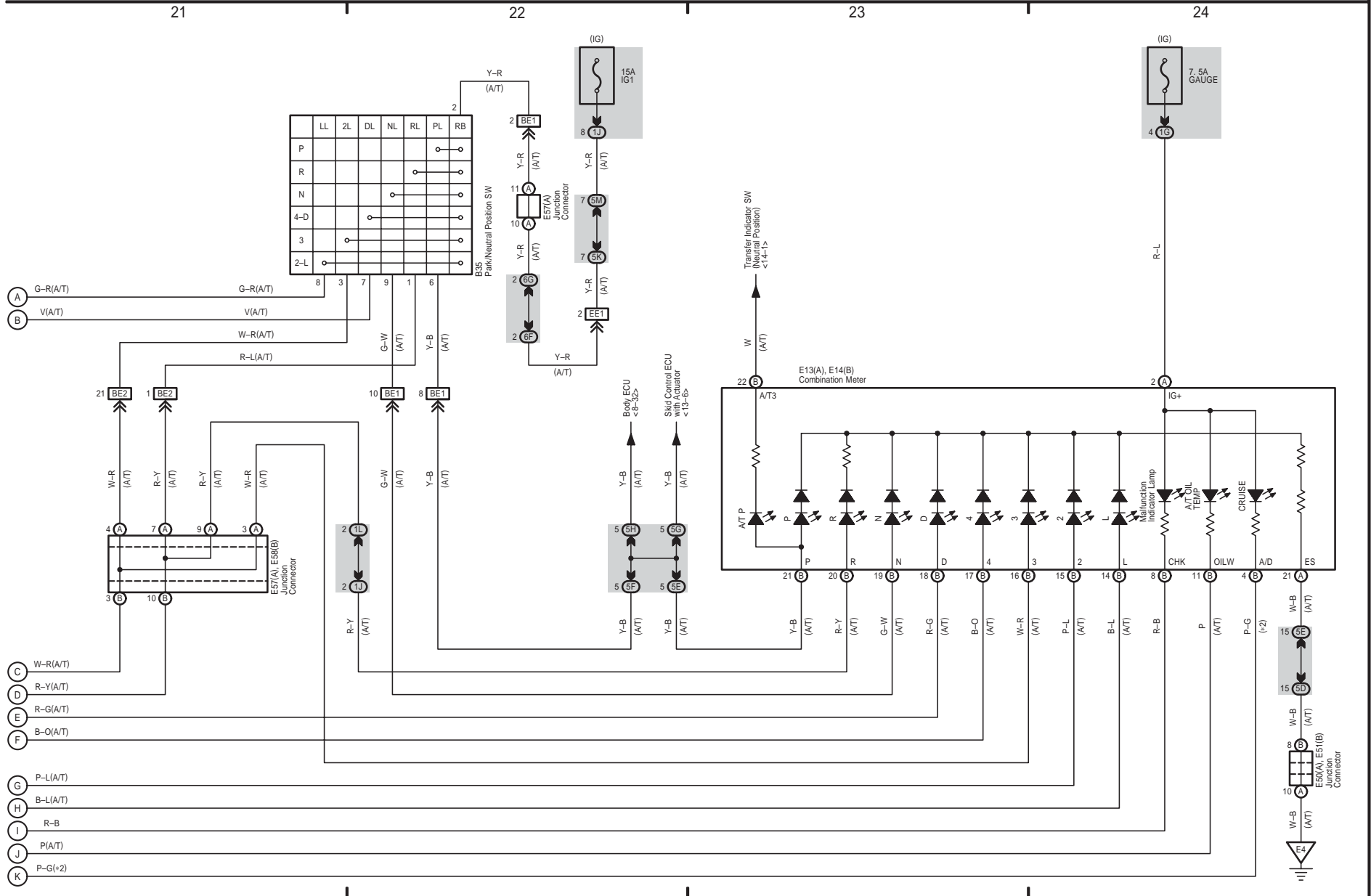

FJ CRUISER (EM0240U)



6 FJ CRUISER

304

FJ CRUISER (EM0240U)

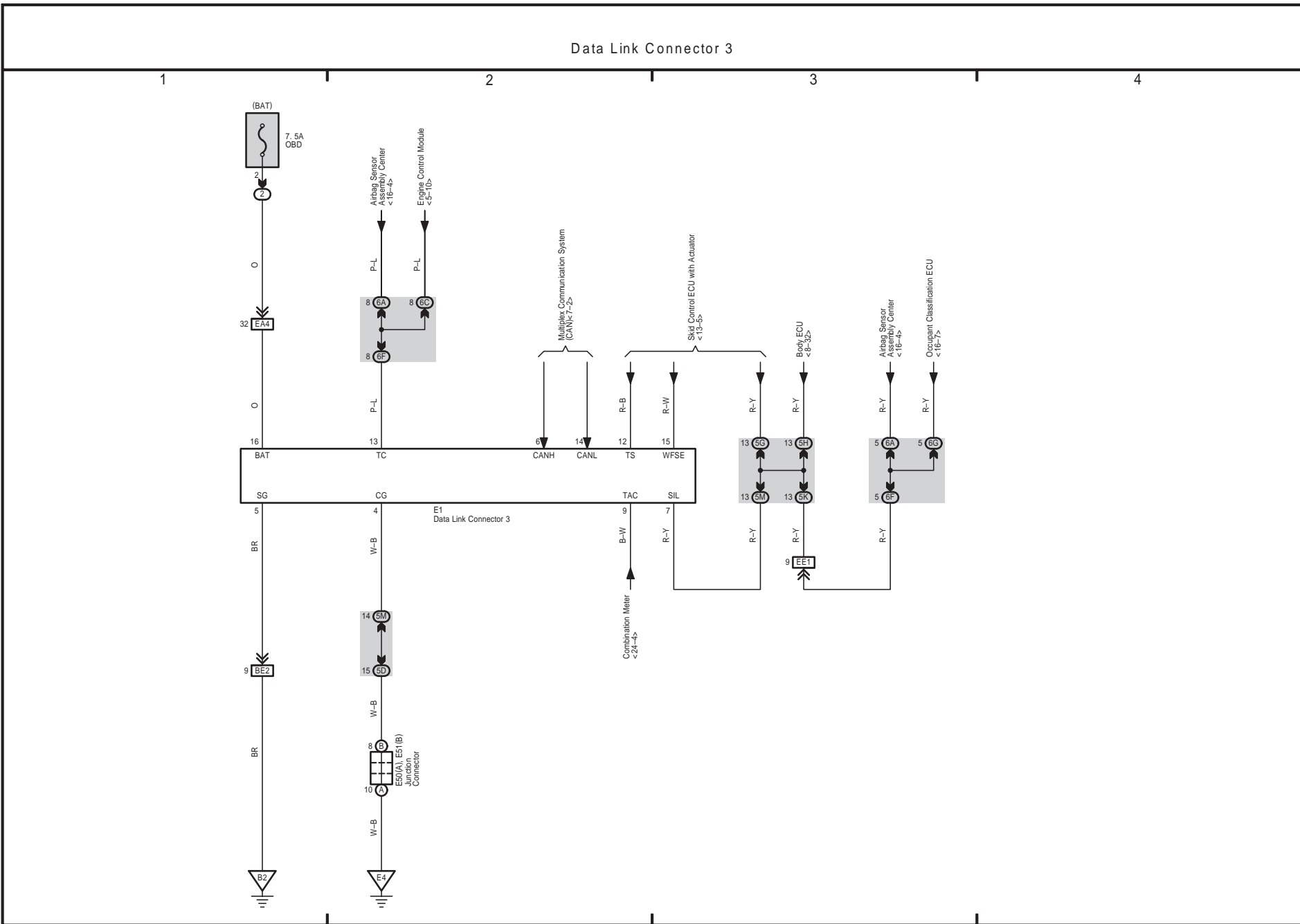

7 FJ CRUISER

Multiplex Communication System (CAN)

1 2 3 4

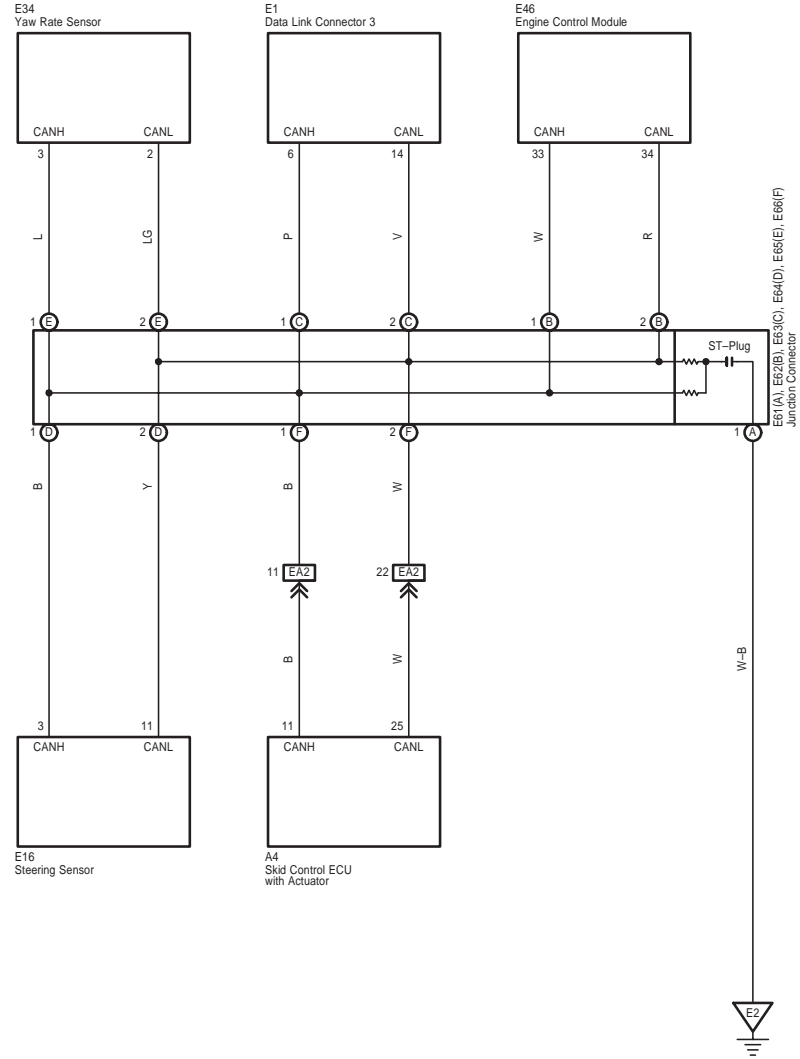

FJ CRUISER (EM0240U)

Multiplex Communication System (BEAN)

* 1 : w/ Daytime Running Light
 * 2 : w/o Daytime Running Light

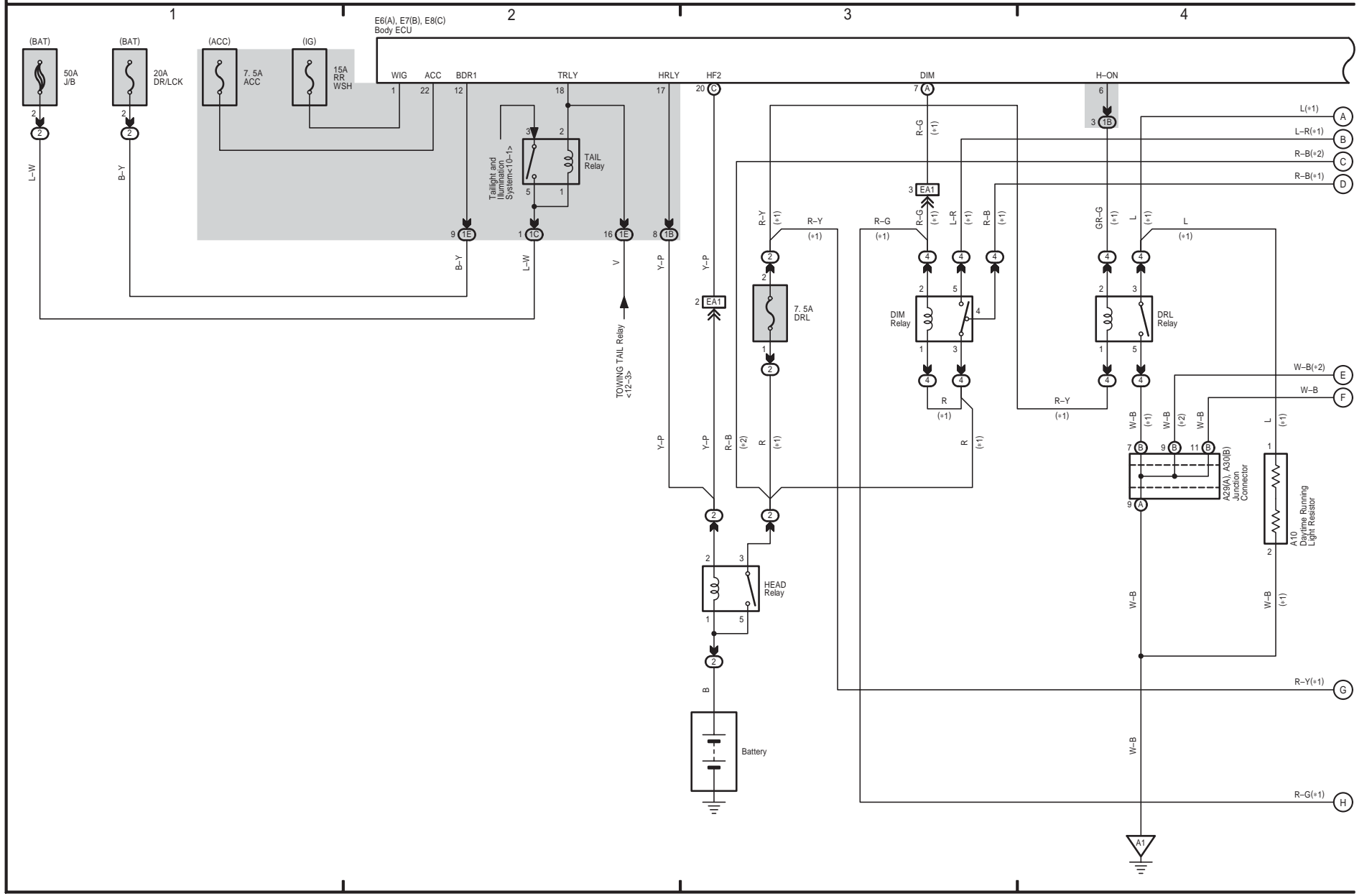

Multiplex Communication System (BEAN)

• 1 : w/ Daytime Running Light
• 2 : w/o Daytime Running Light

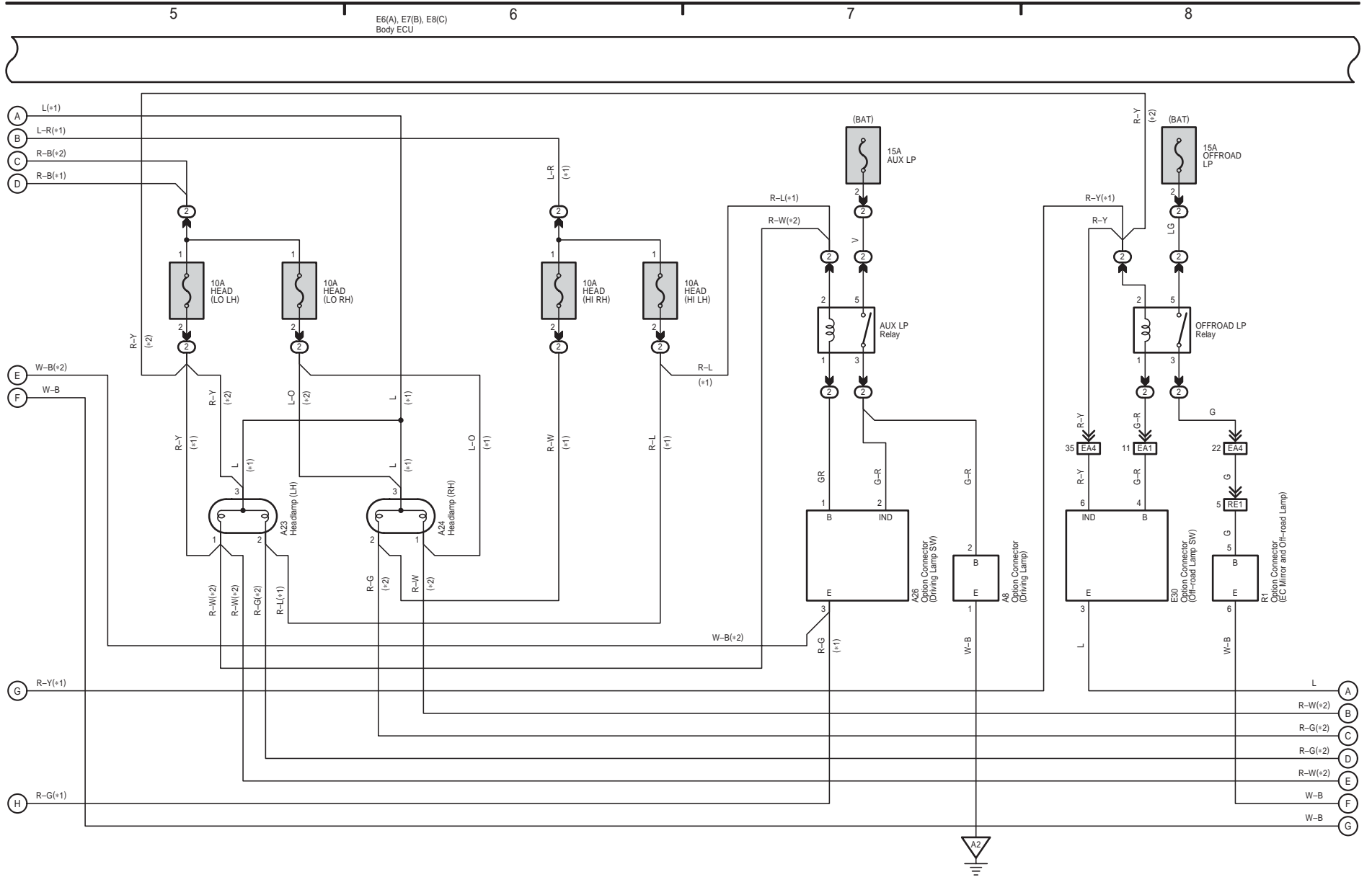

FJ CRUISER (EM0240U)



Multiplex Communication System (BEAN)

* 1 : w/ Daytime Running Light
* 2 : w/o Daytime Running Light

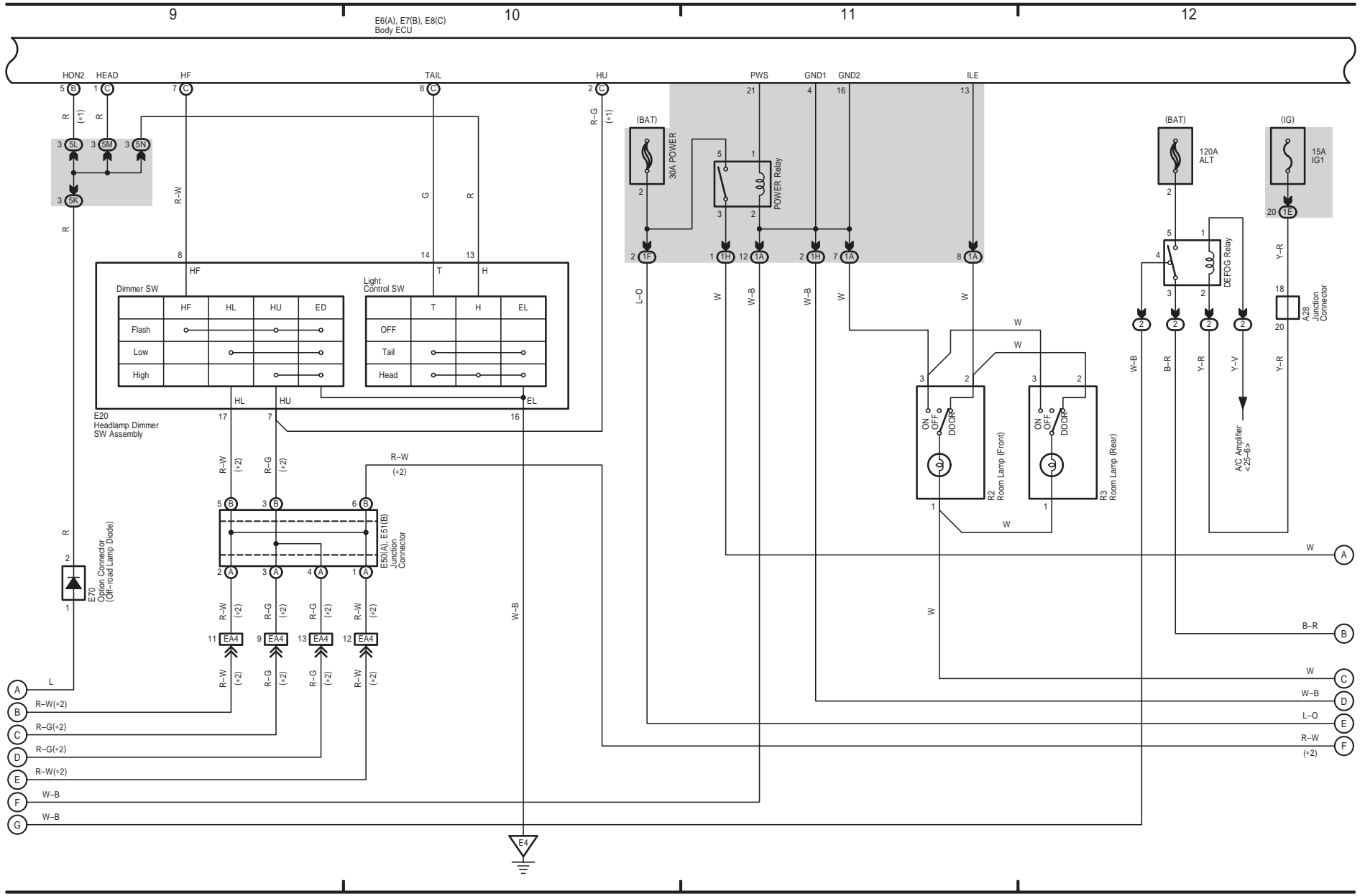

Multiplex Communication System (BEAN)

* 2 : w/o Daytime Running Light

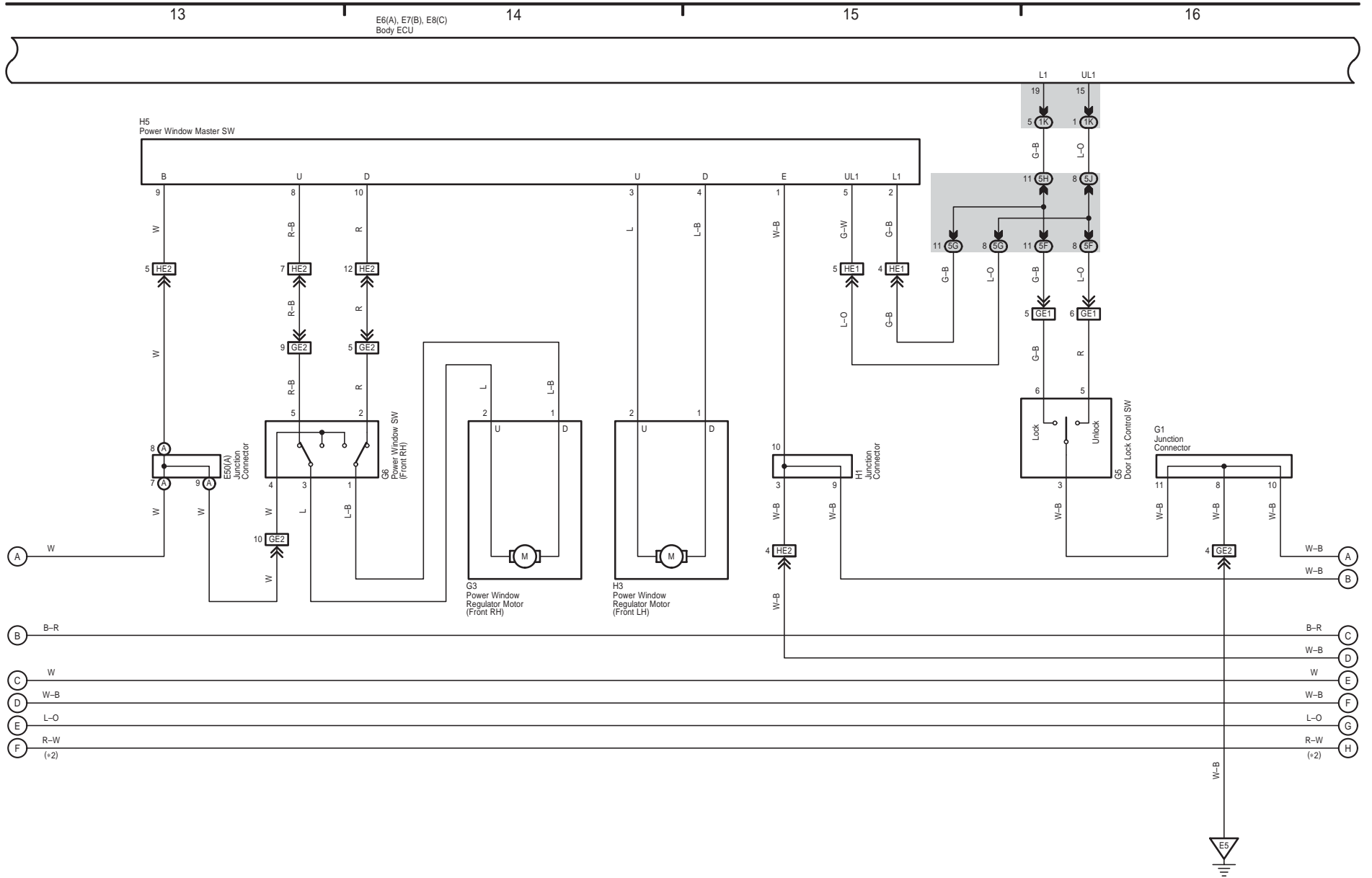

FJ CRUISER (EM0240U)



Multiplex Communication System (BEAN)

* 2 : w/o Daytime Running Light

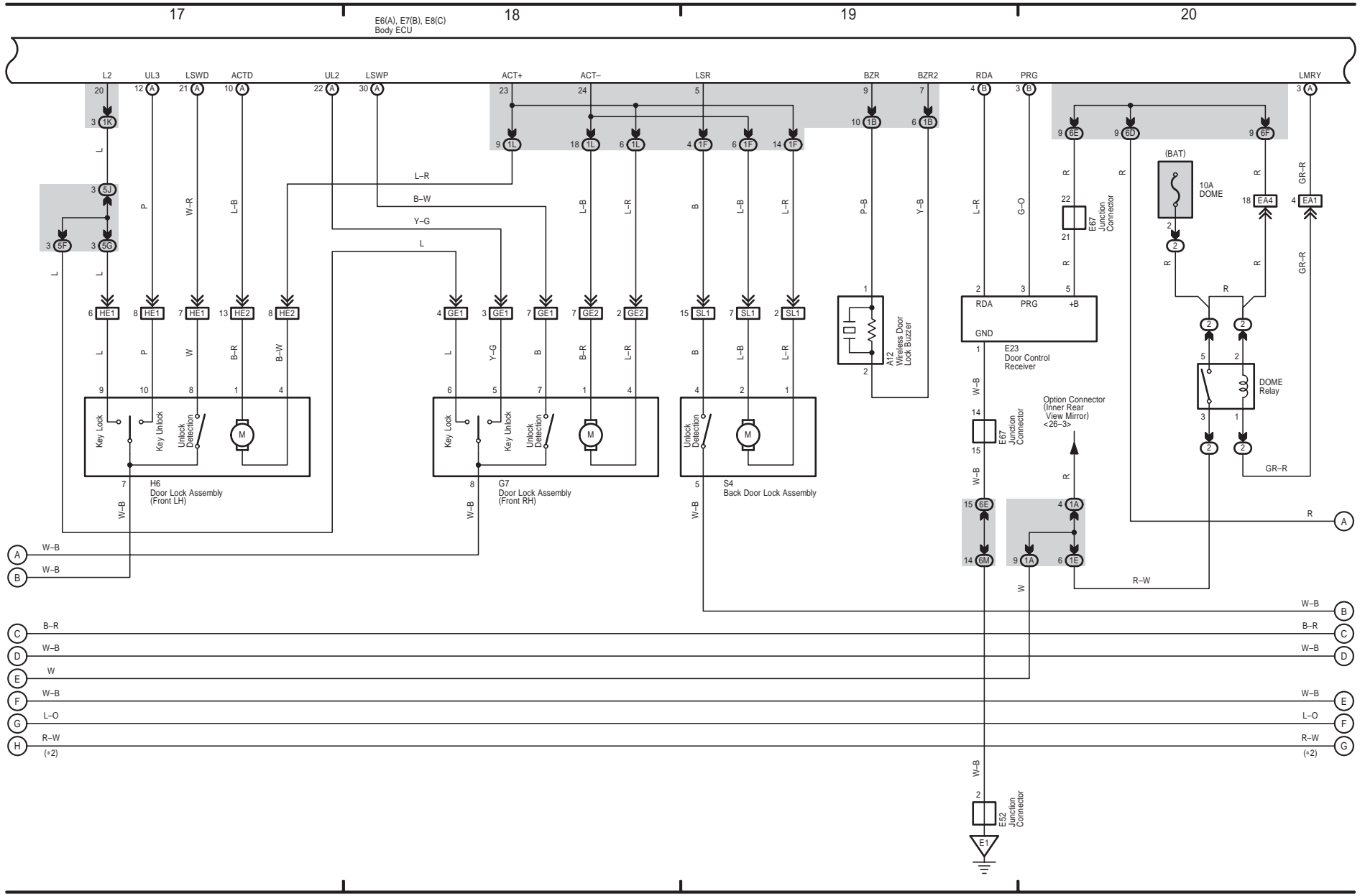

FJ CRUISER (EM0240U)

Multiplex Communication System (BEAN)

• 1 : w/ Daytime Running Light
• 2 : w/o Daytime Running Light

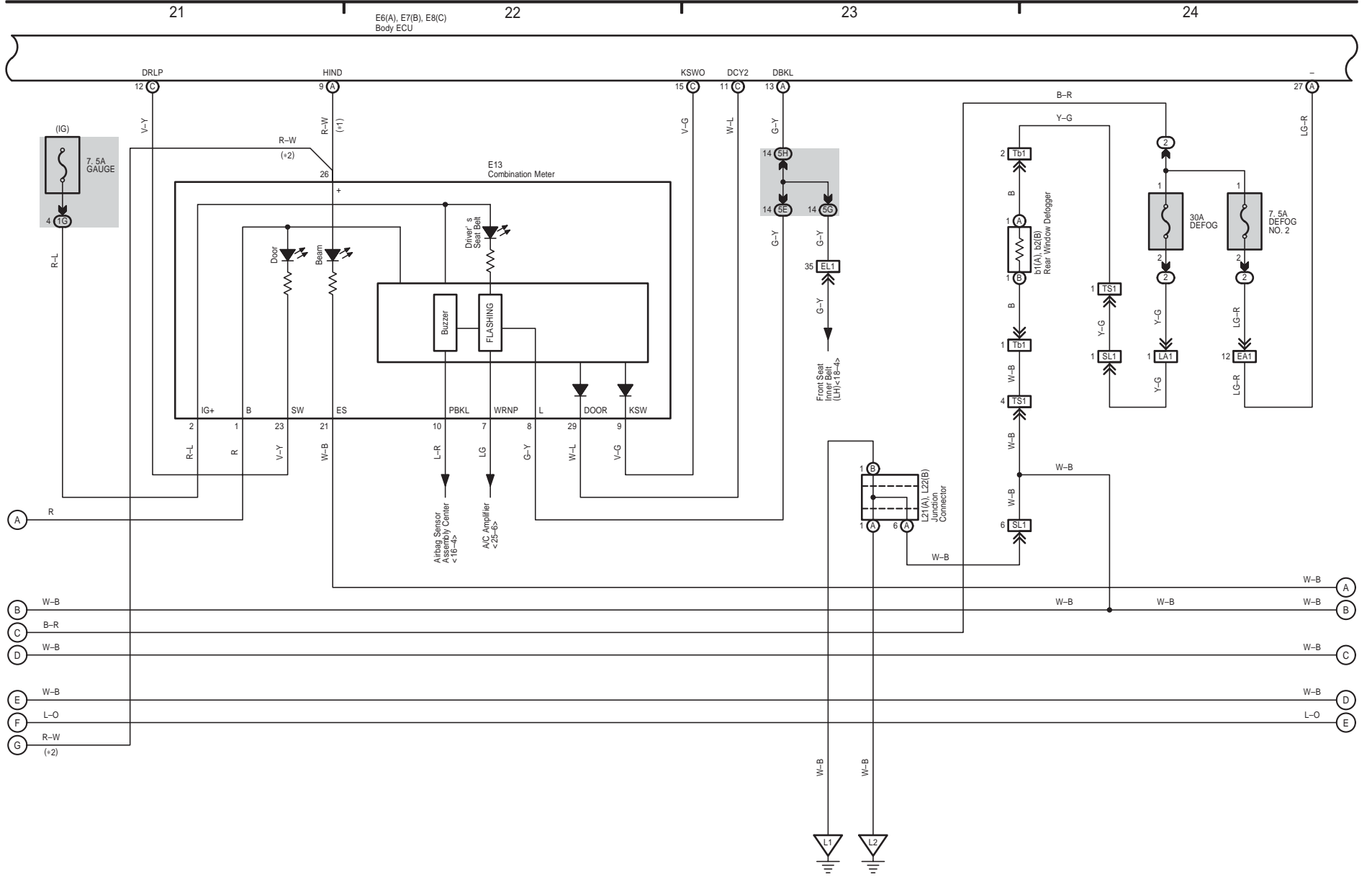

FJ CRUISER (EM0240U)



FJ CRUISER (EM0240U)

Multiplex Communication System (BEAN)

* 3 : w/ Rear Wiper

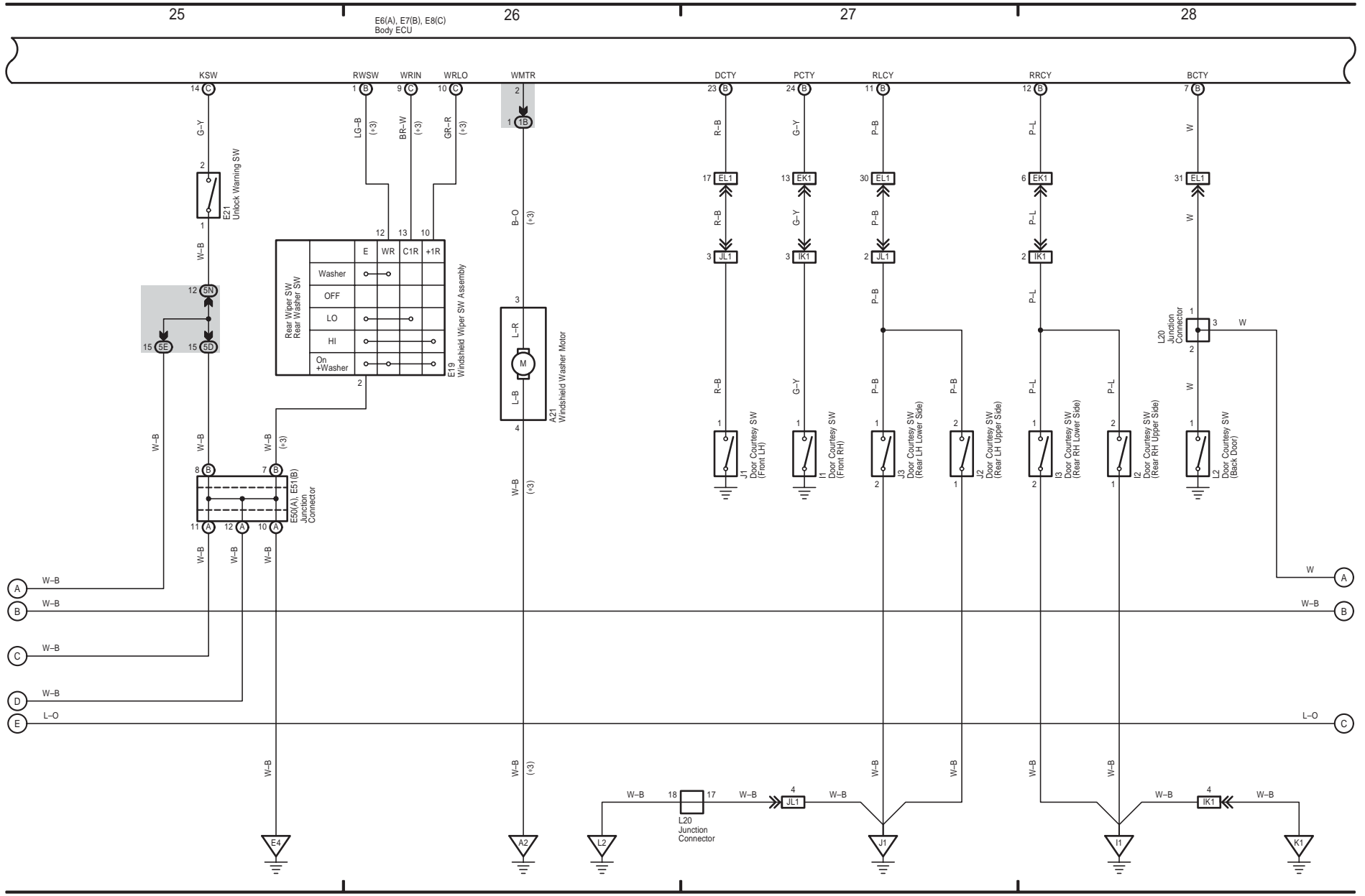

Multiplex Communication System (BEAN)

* 1 : w/ Daytime Running Light

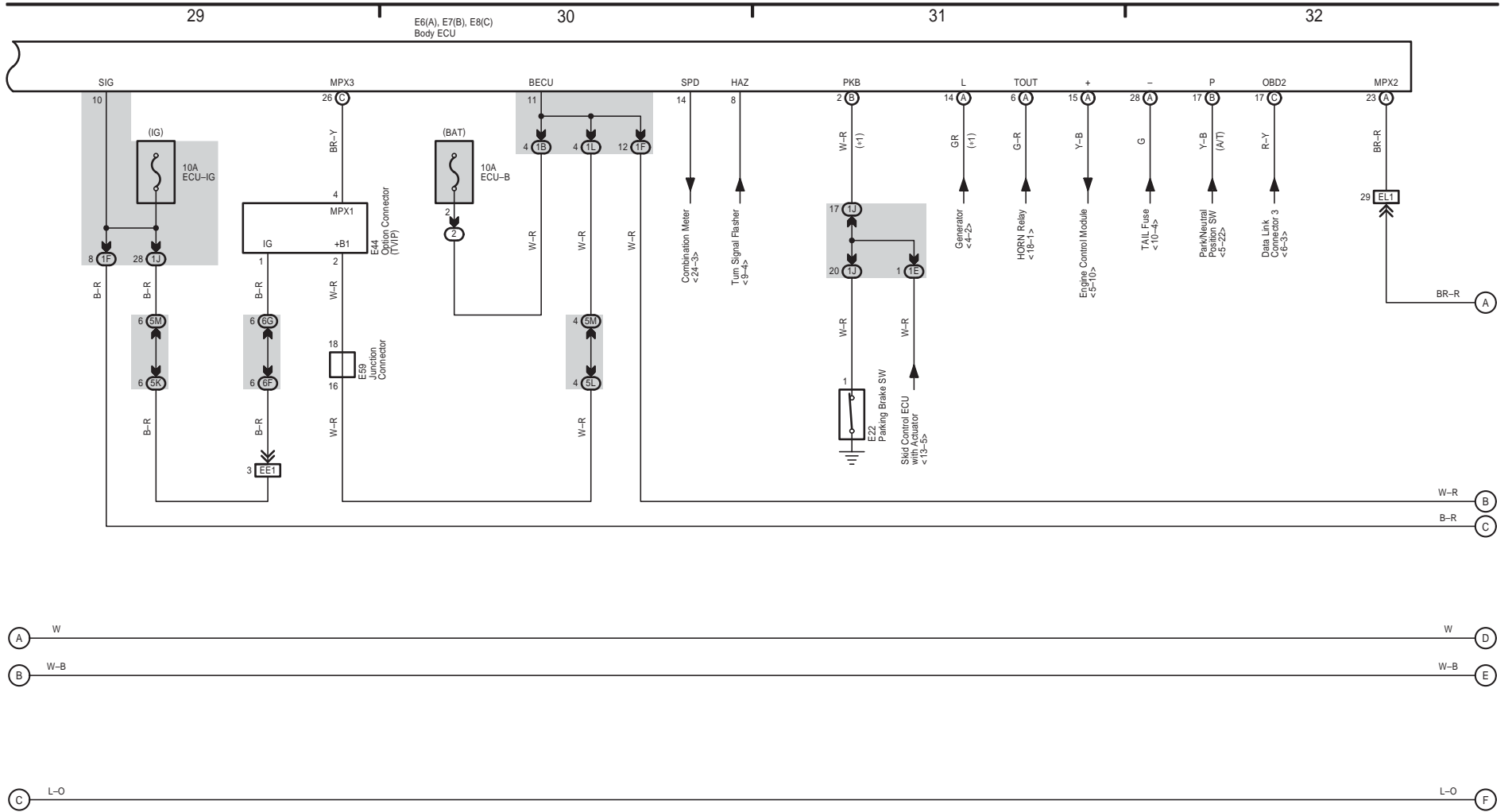

FJ CRUISER (EM0240U)



8 FJ CRUISER (Cont' d)

Multiplex Communication System (BEAN)

* 3 : w/ Rear Wiper
* 4 : w/o Rear Wiper

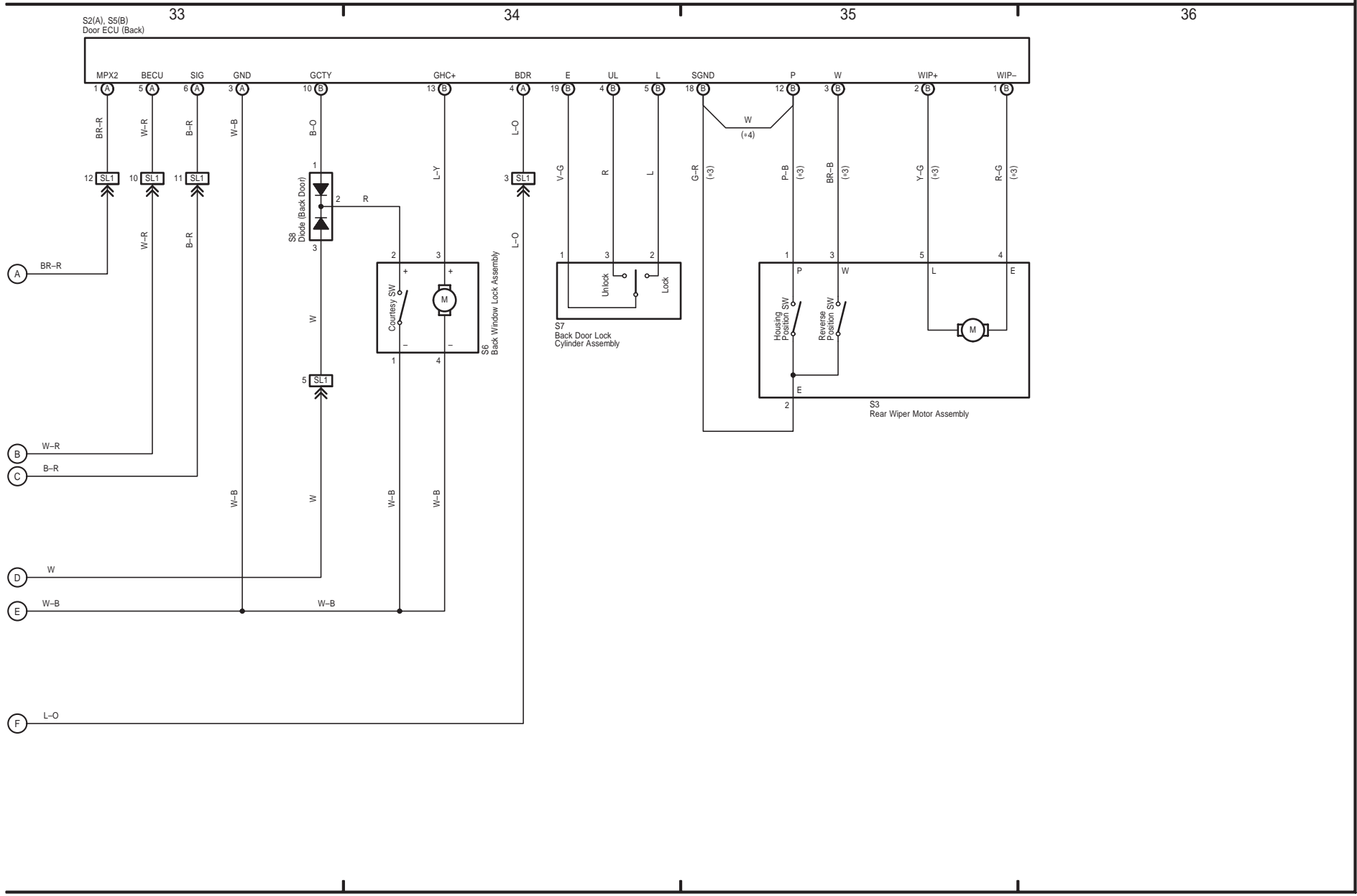

Turn Signal and Hazard Warning Light

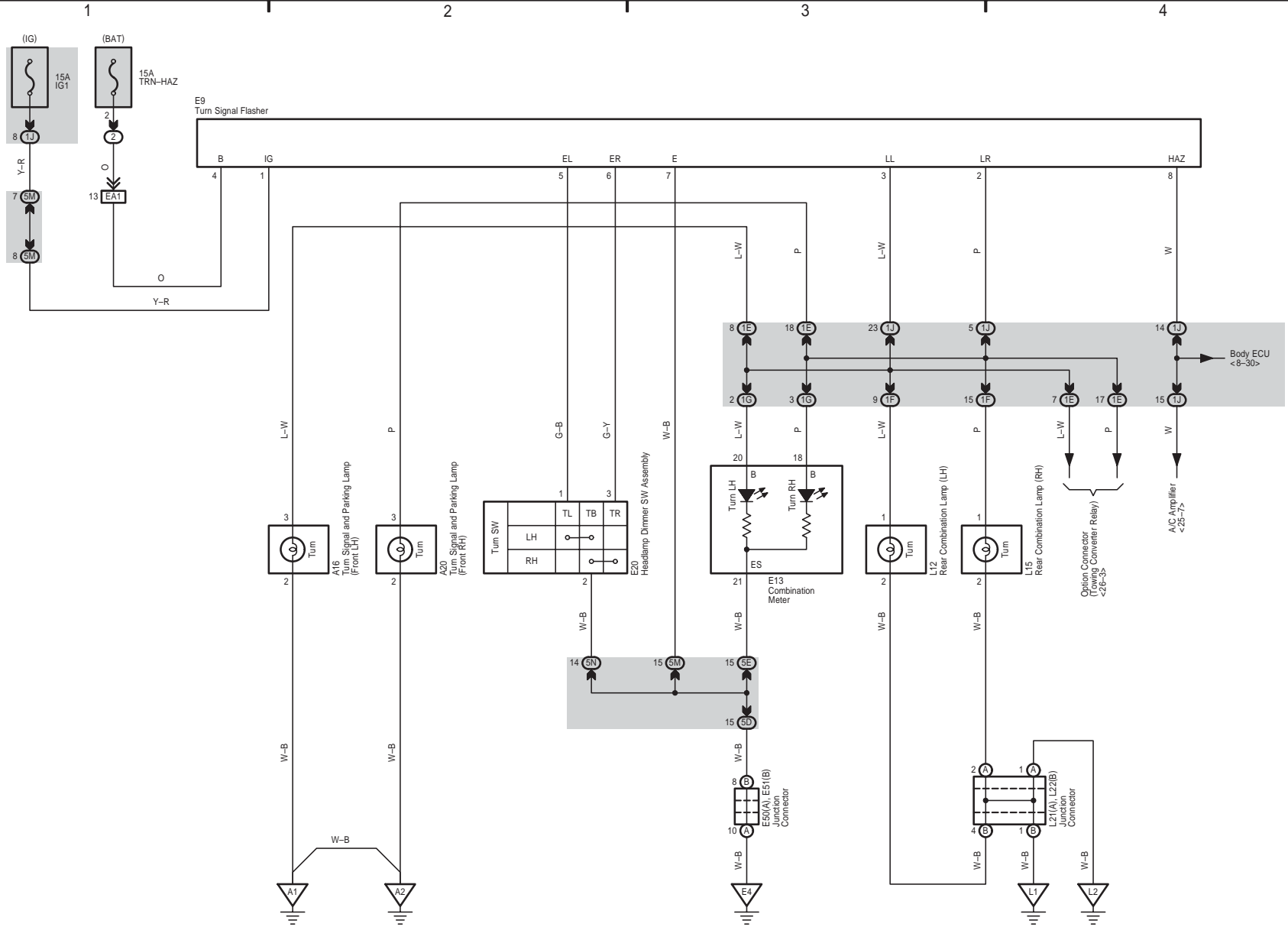

Taillight and Illumination

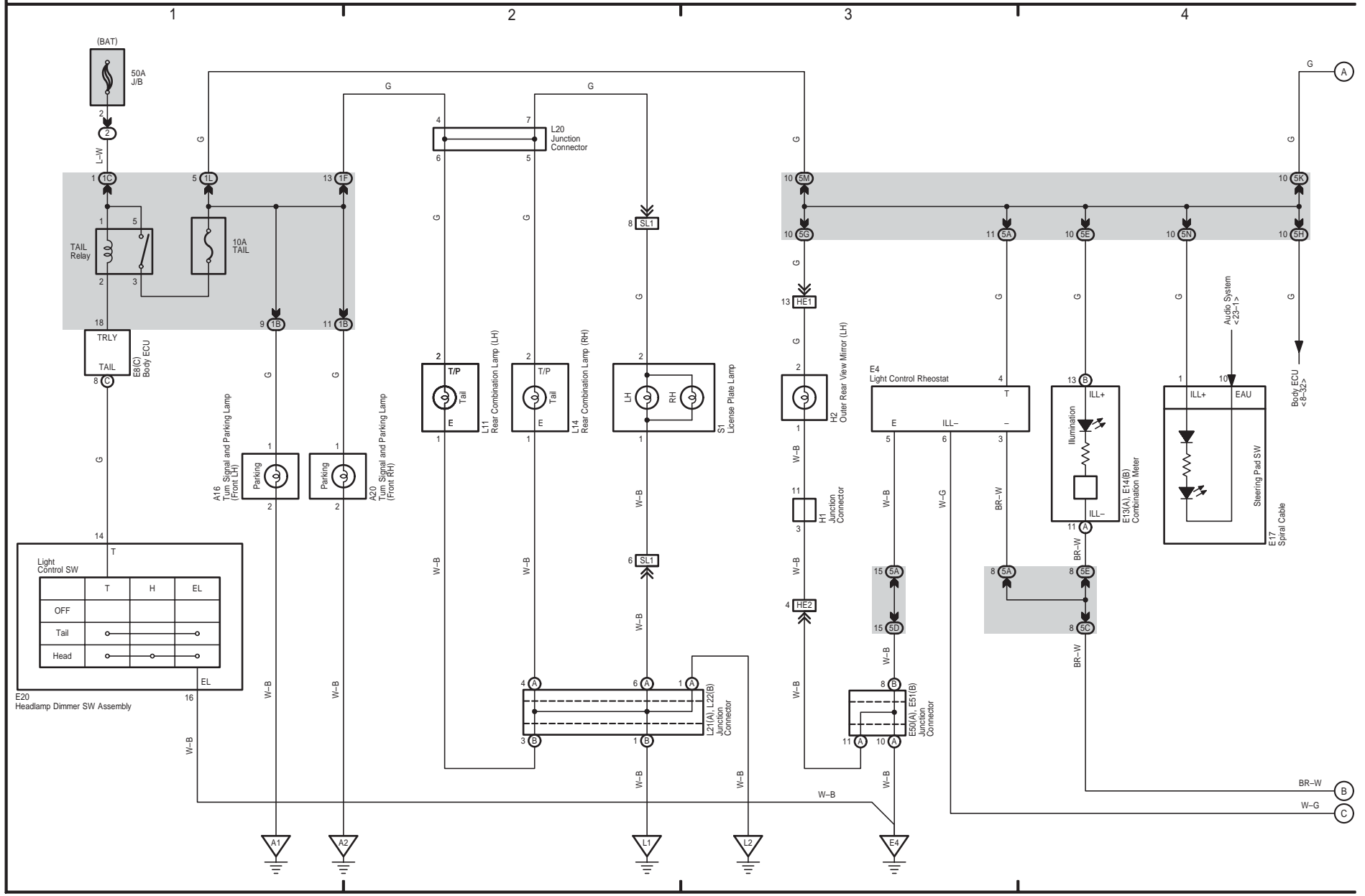

Taillight and Illumination

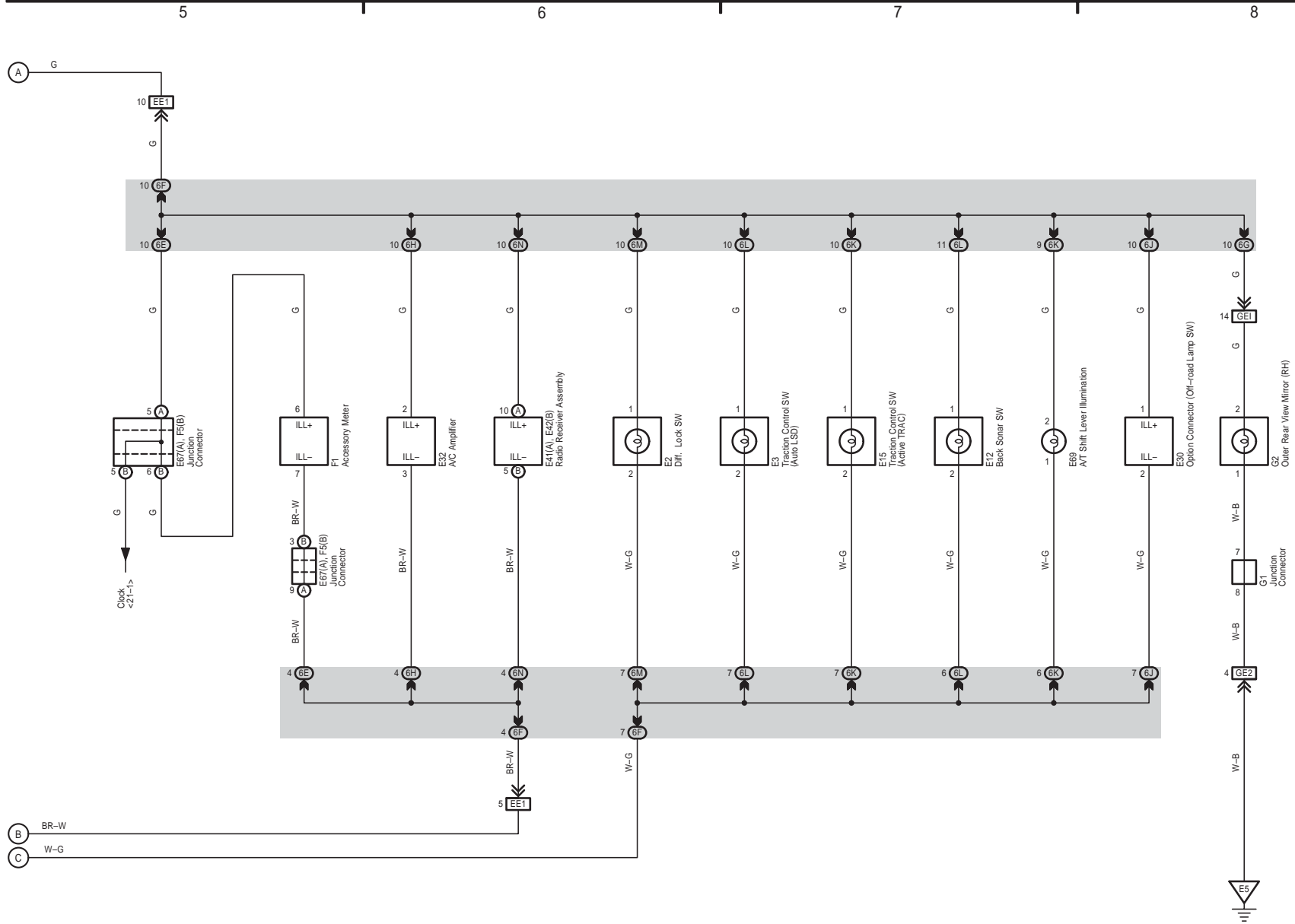

FJ CRUISER (EM0240U)

11 FJ CRUISER

M OVERALL ELECTRICAL WIRING DIAGRAM

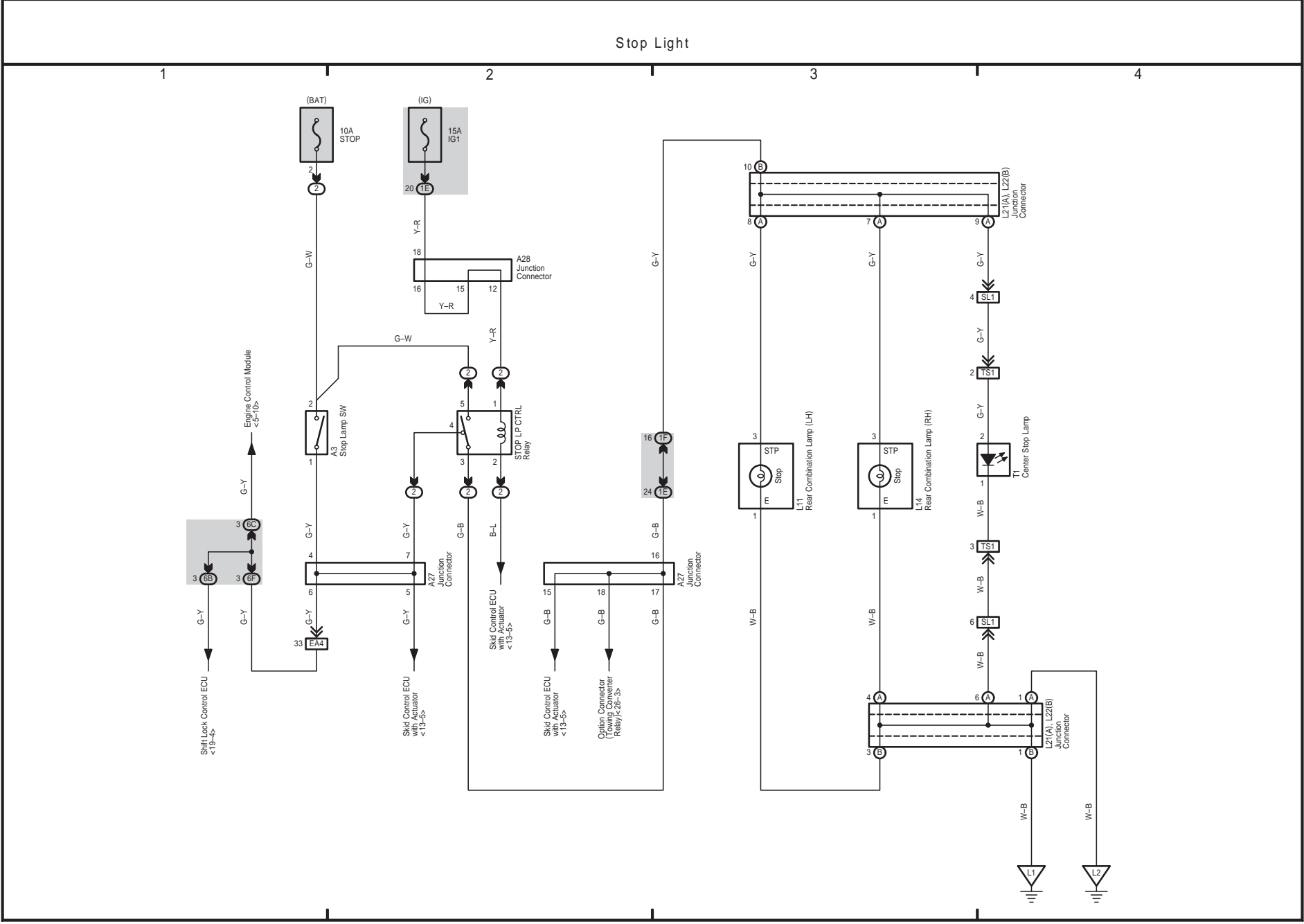

Back-Up Light

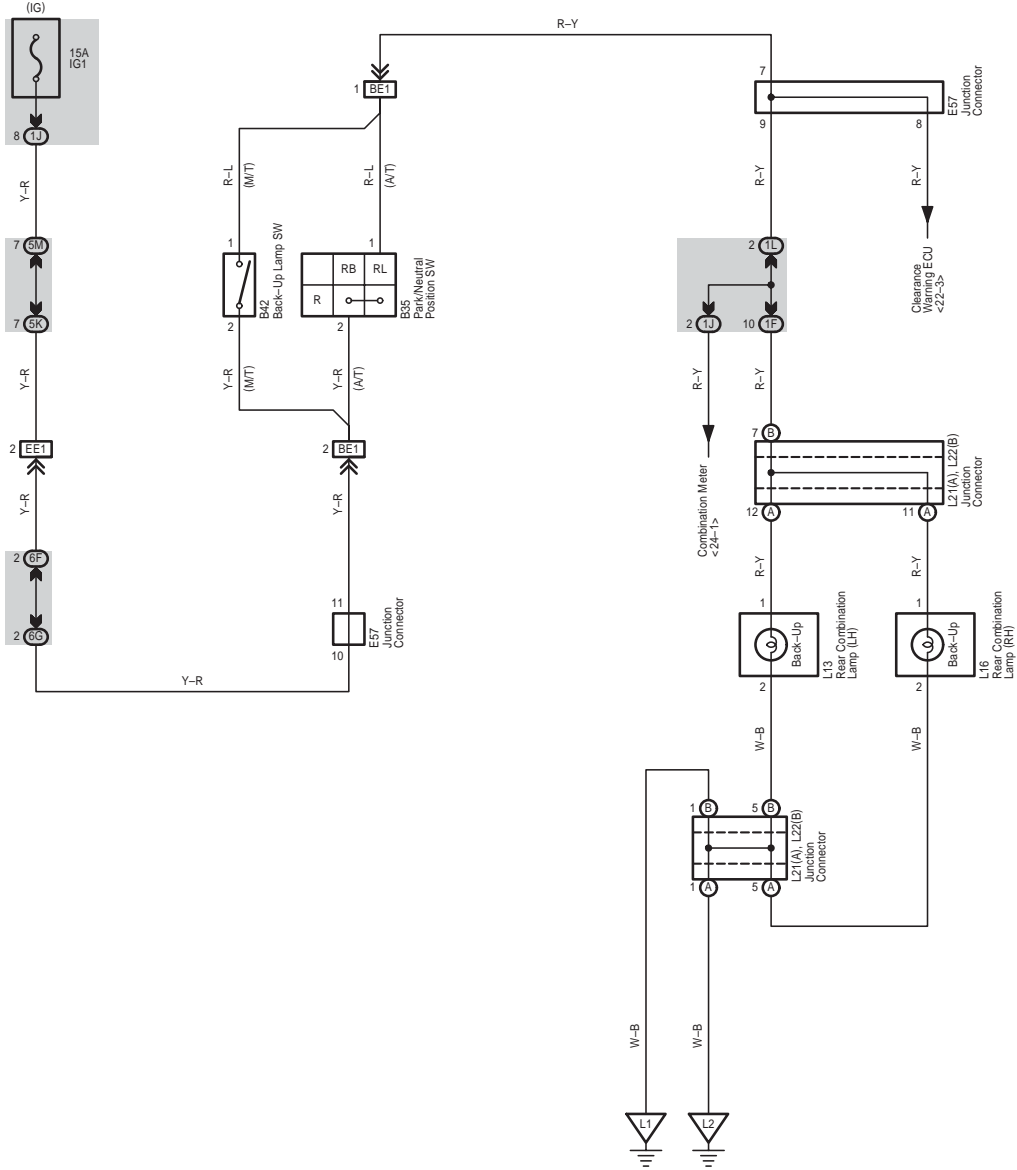

ABS, TRAC, VSC and Auto LSD

* 1 : Shielded

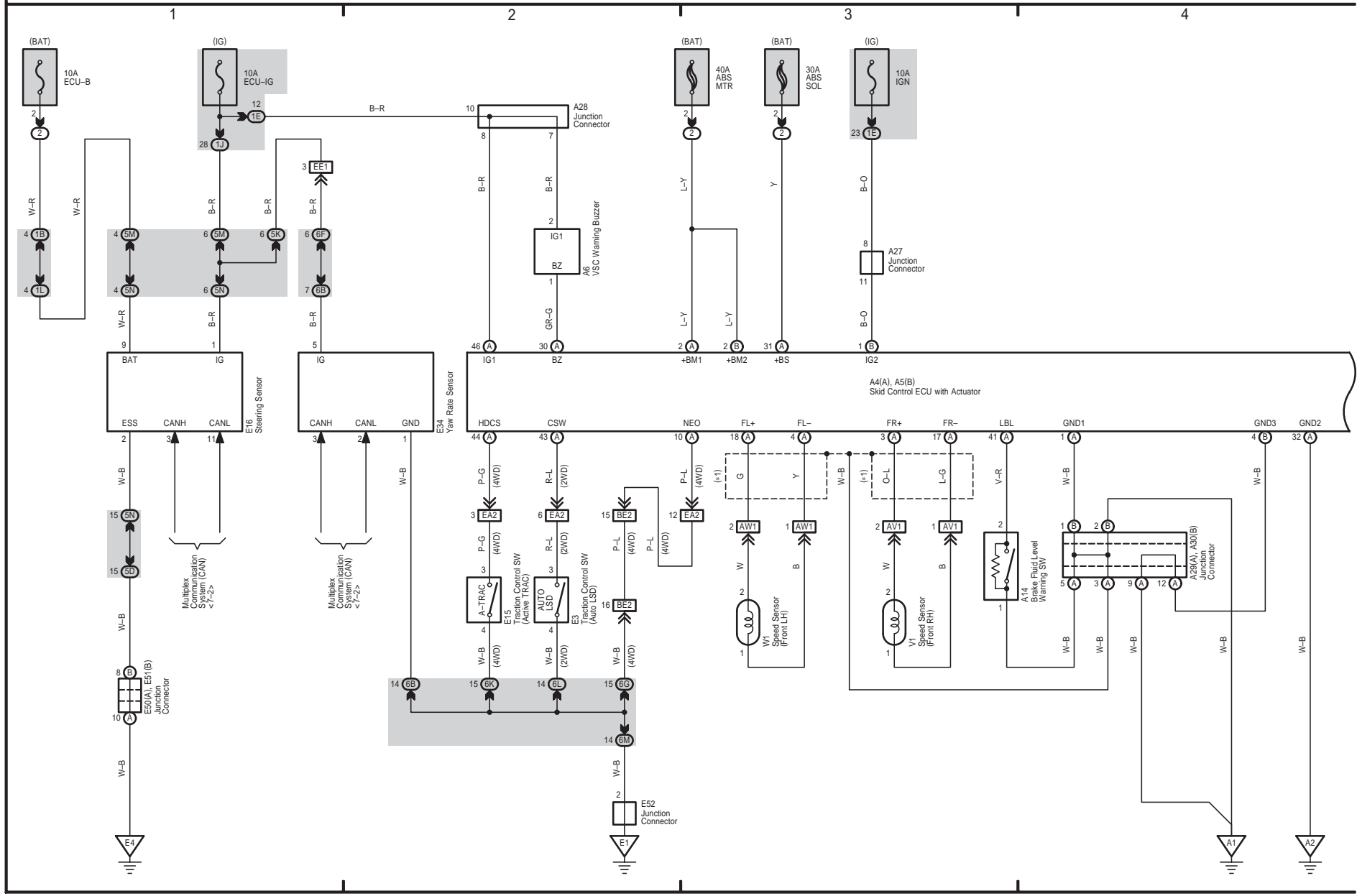

ABS, TRAC, VSC and Auto LSD

* 2 : w/ Rear Diff. Lock
 * 3 : 4WD, 2WD w/ Rear Diff. Lock

FJ CRUISER (EM0240U)

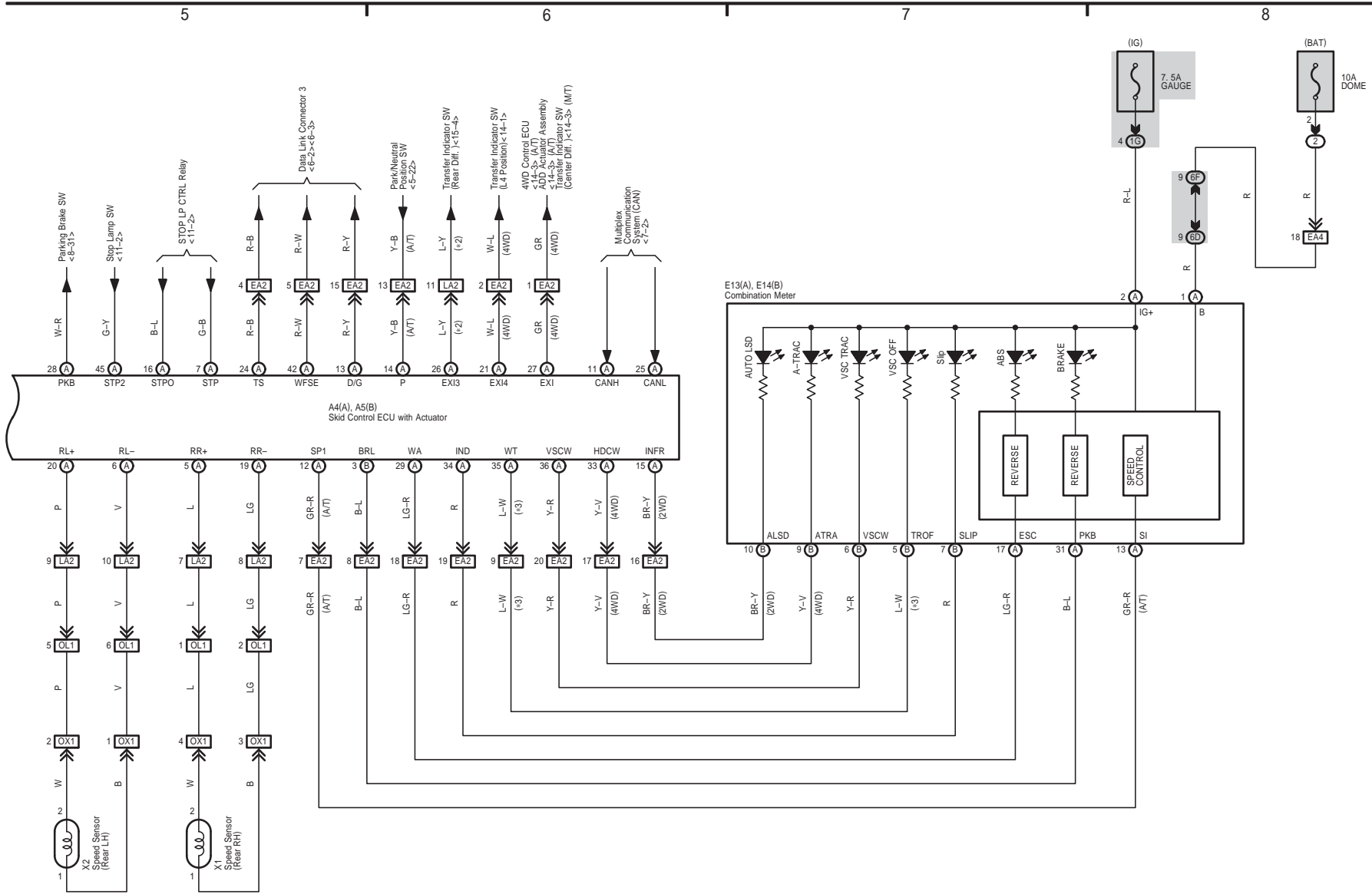

14 FJ CRUISER

4WD

* 1 : w/ Rear Diff. Lock

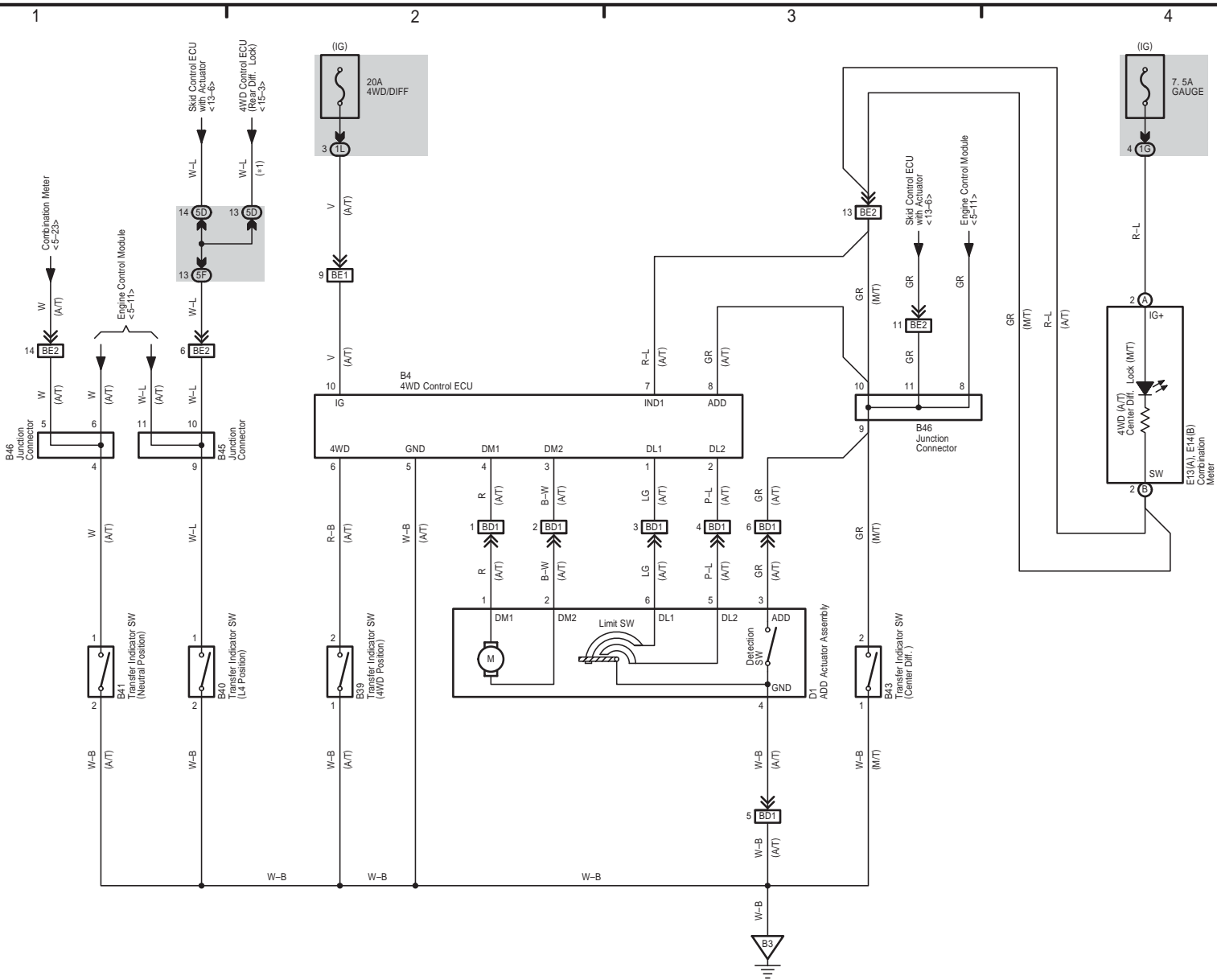

Rear Differential Lock

FJ CRUISER (EM0240U)

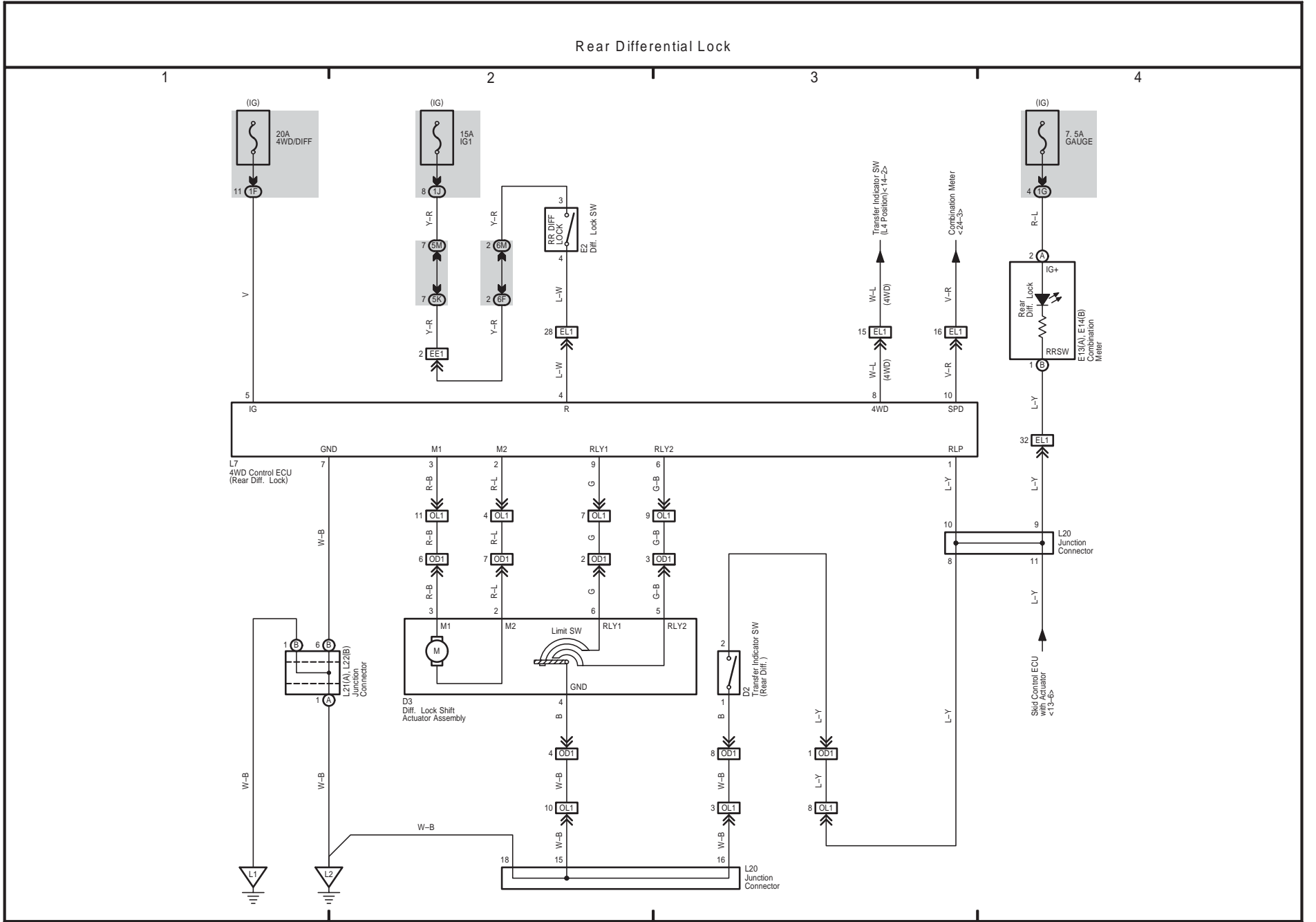

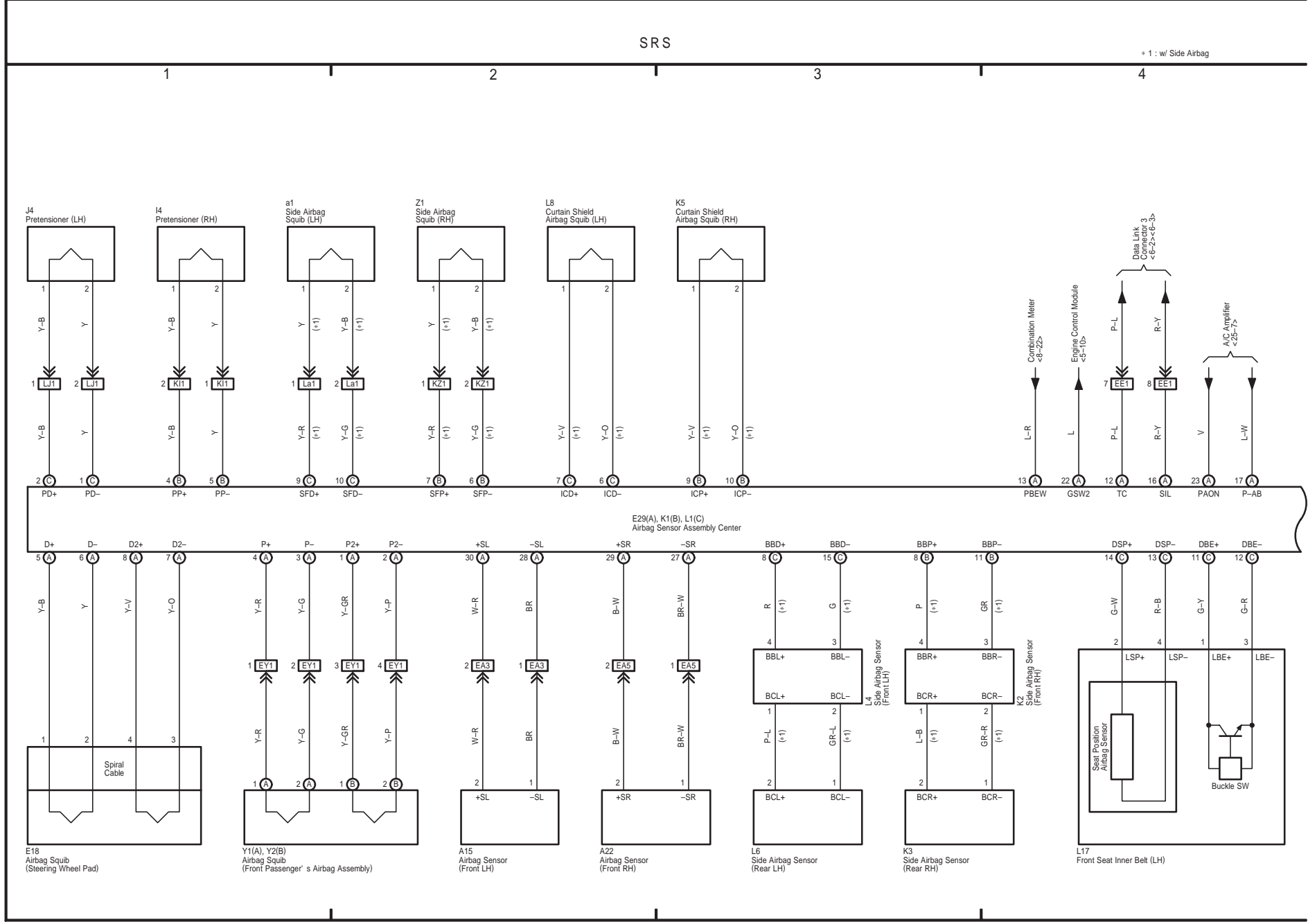

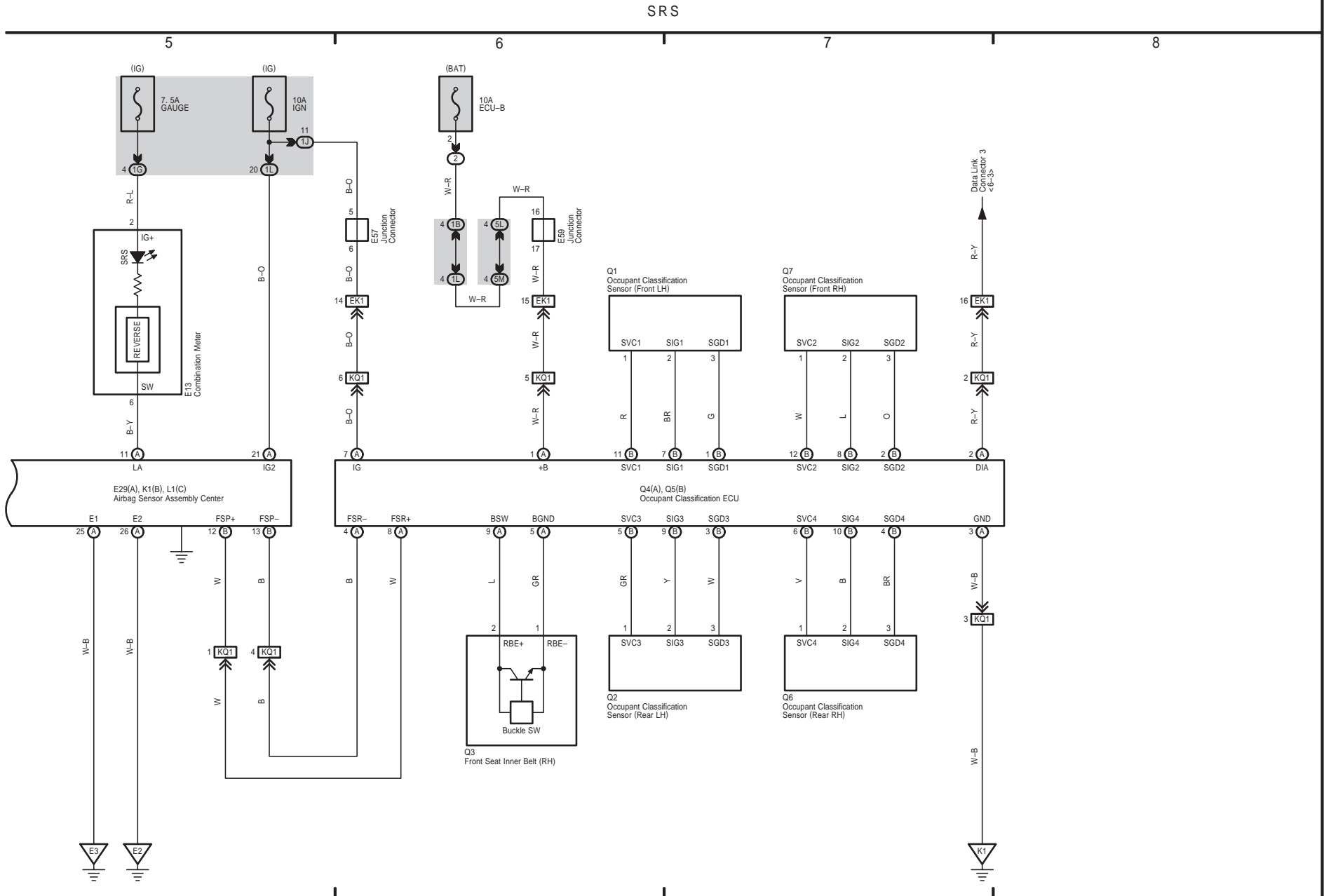

17 FJ CRUISER

Front Wiper and Washer

1 2 3 4

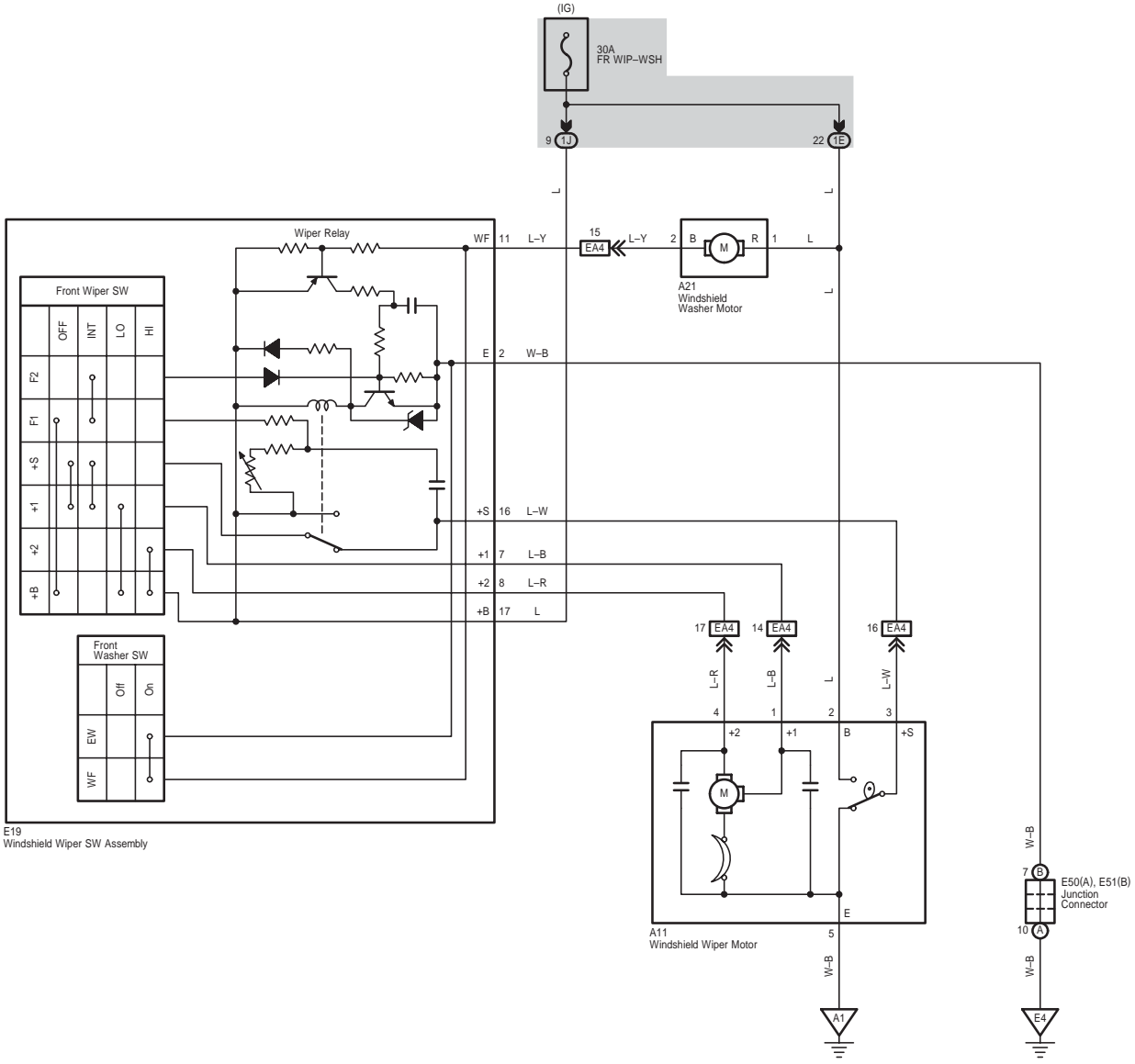

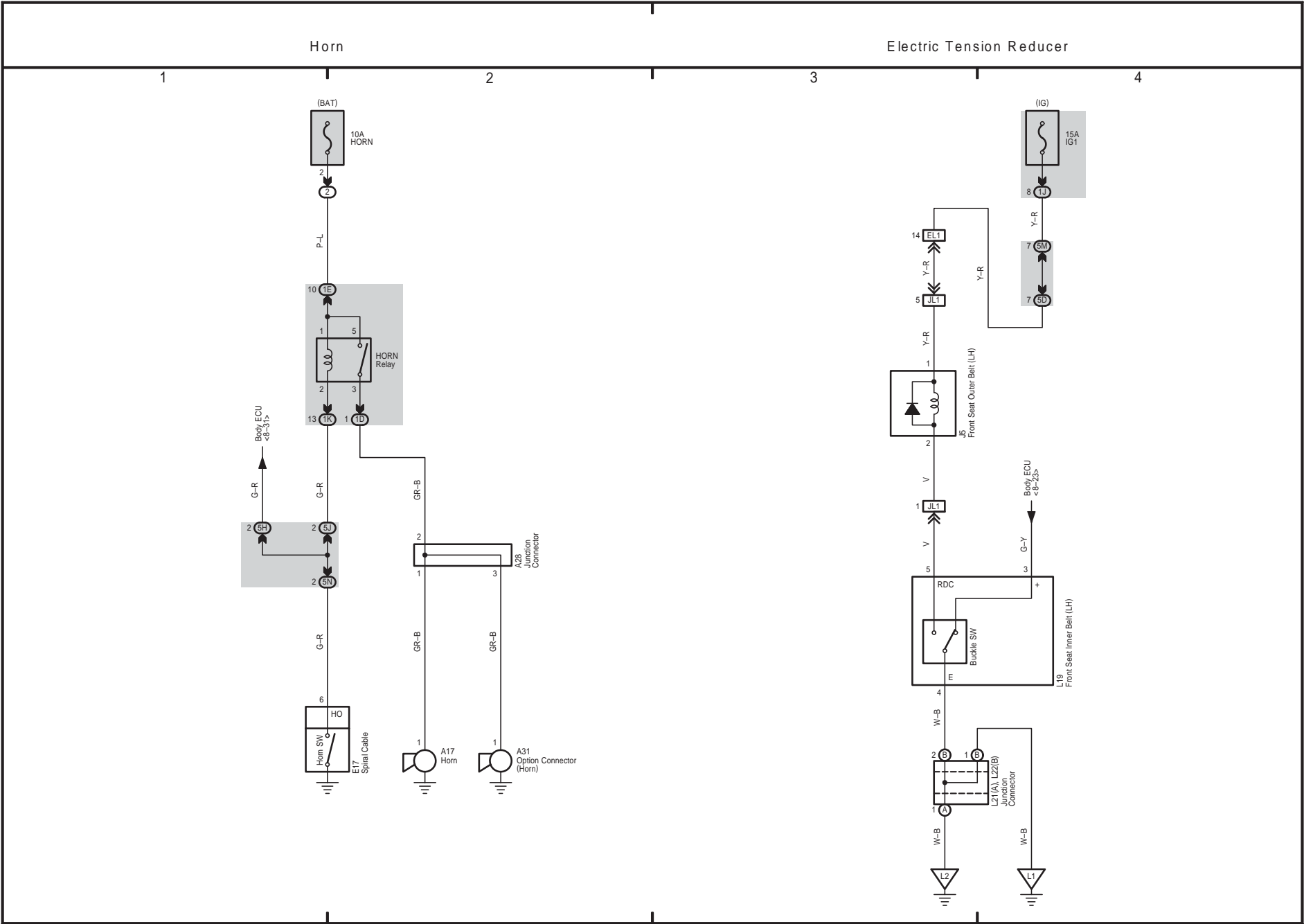

19 FJ CRUISER

Remote Control Mirror

Shift Lock

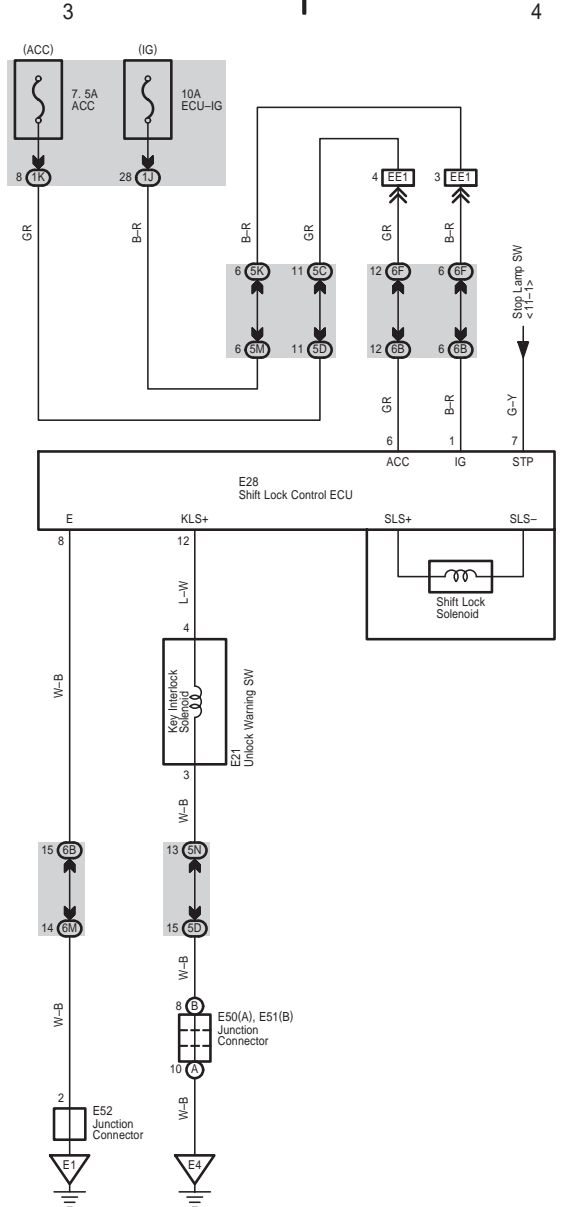
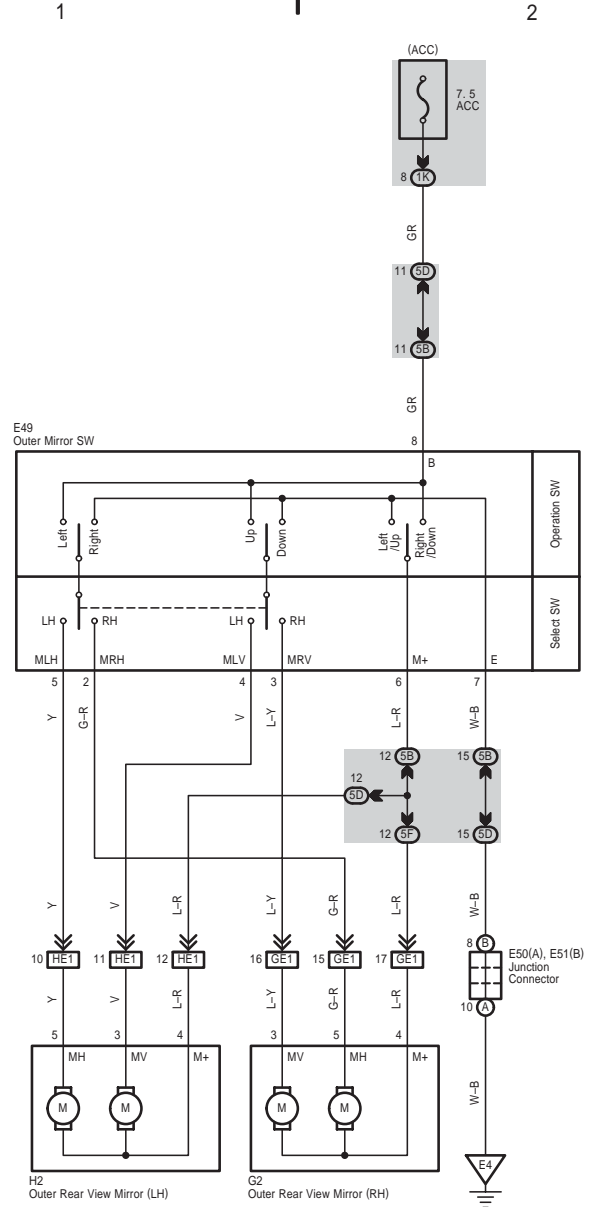

21 FJ CRUISER

OVERALL ELECTRICAL WIRING DIAGRAM

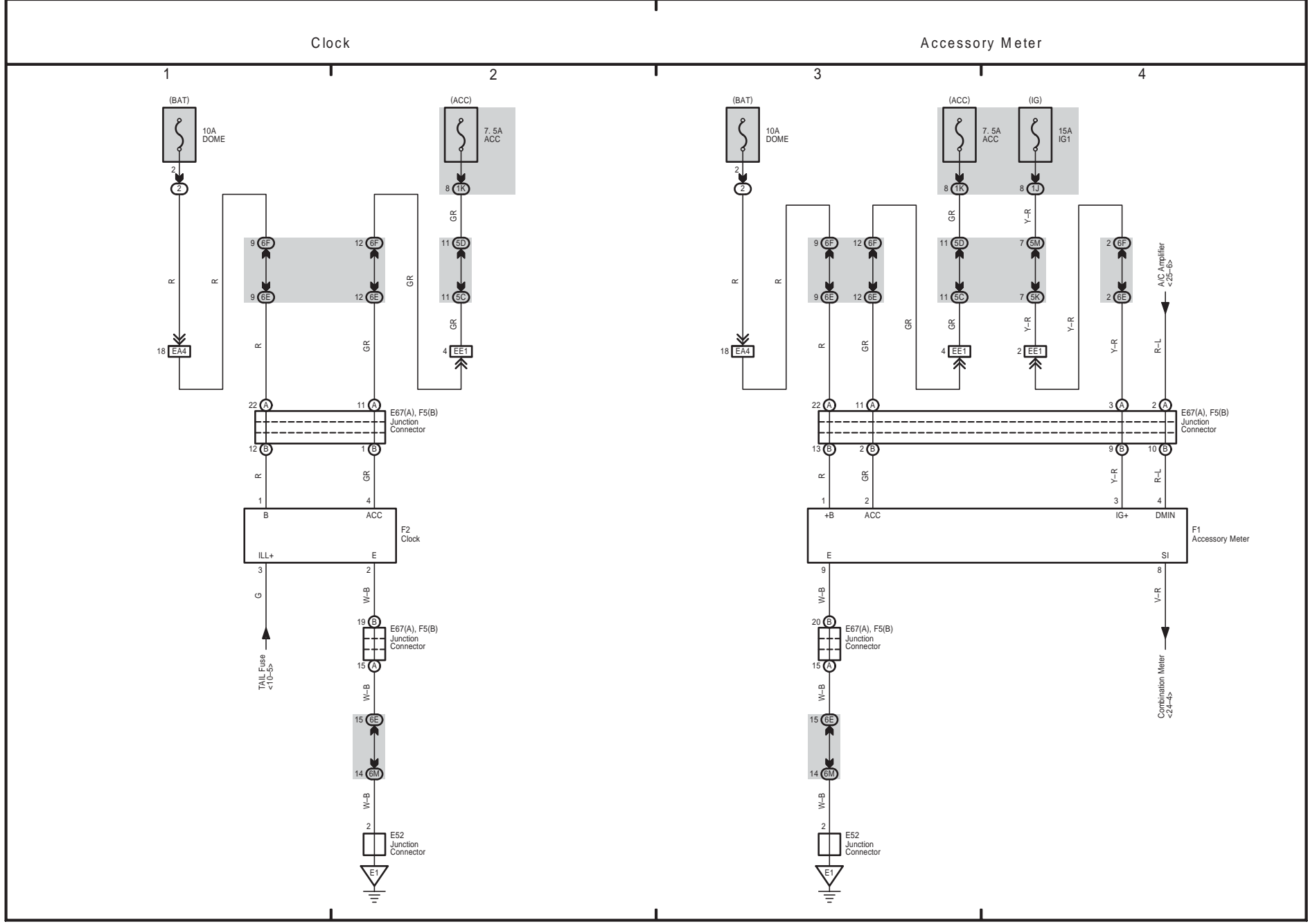

TOYOTA Parking Assist (Clearance Sonar)

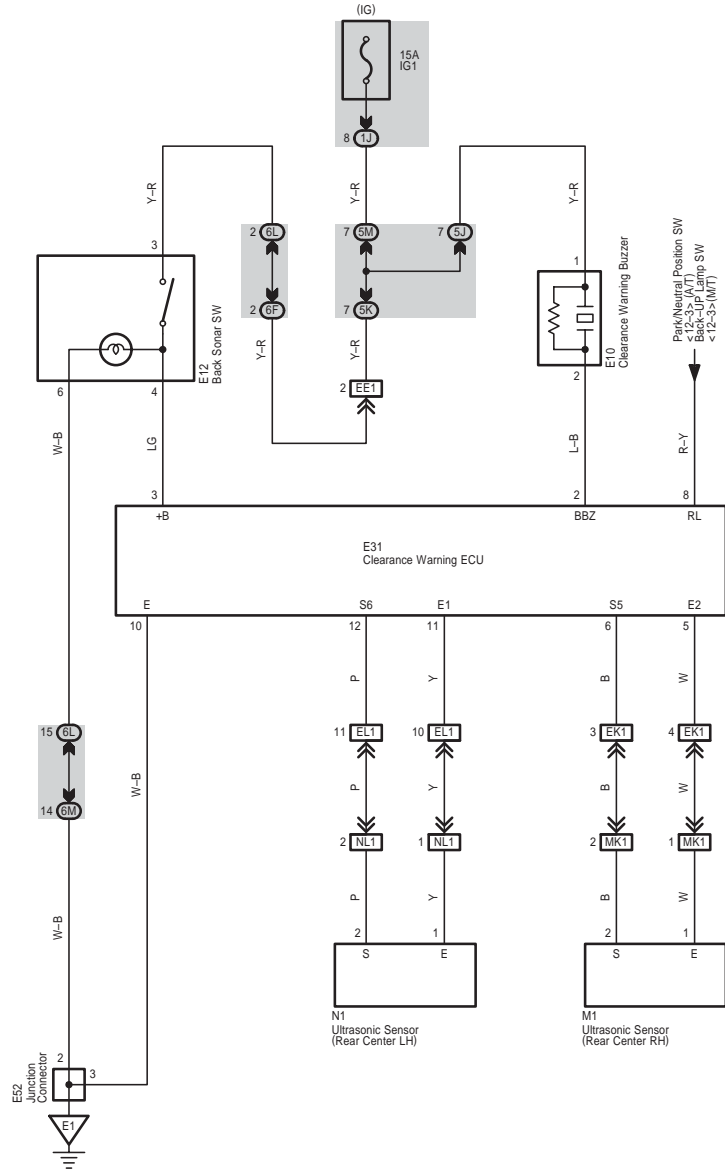

Audio System

* 1 : w Wooler

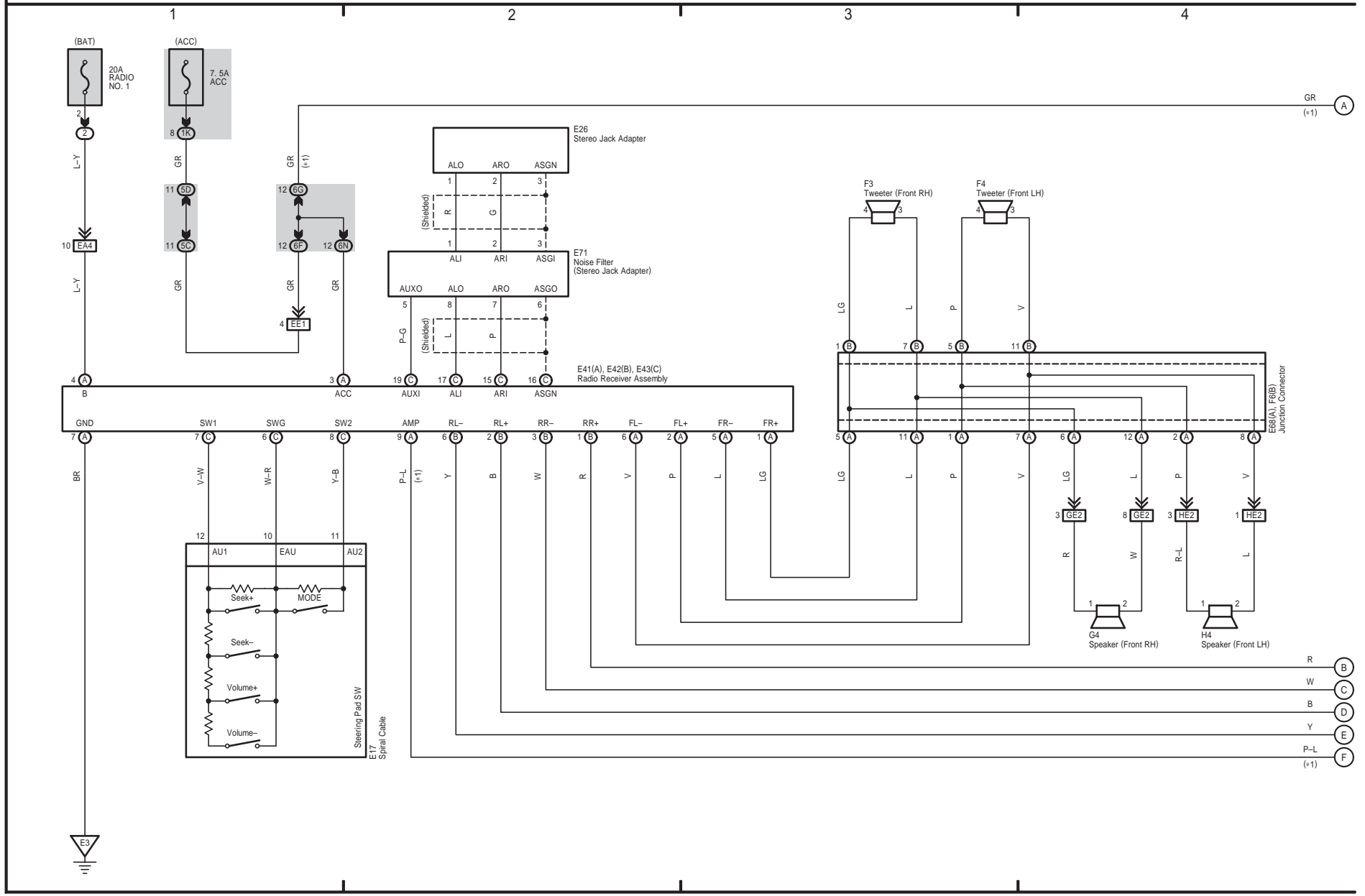

Audio System

* 1 : w/ Woofer
 * 2 : 9 Speaker, 8 Speaker

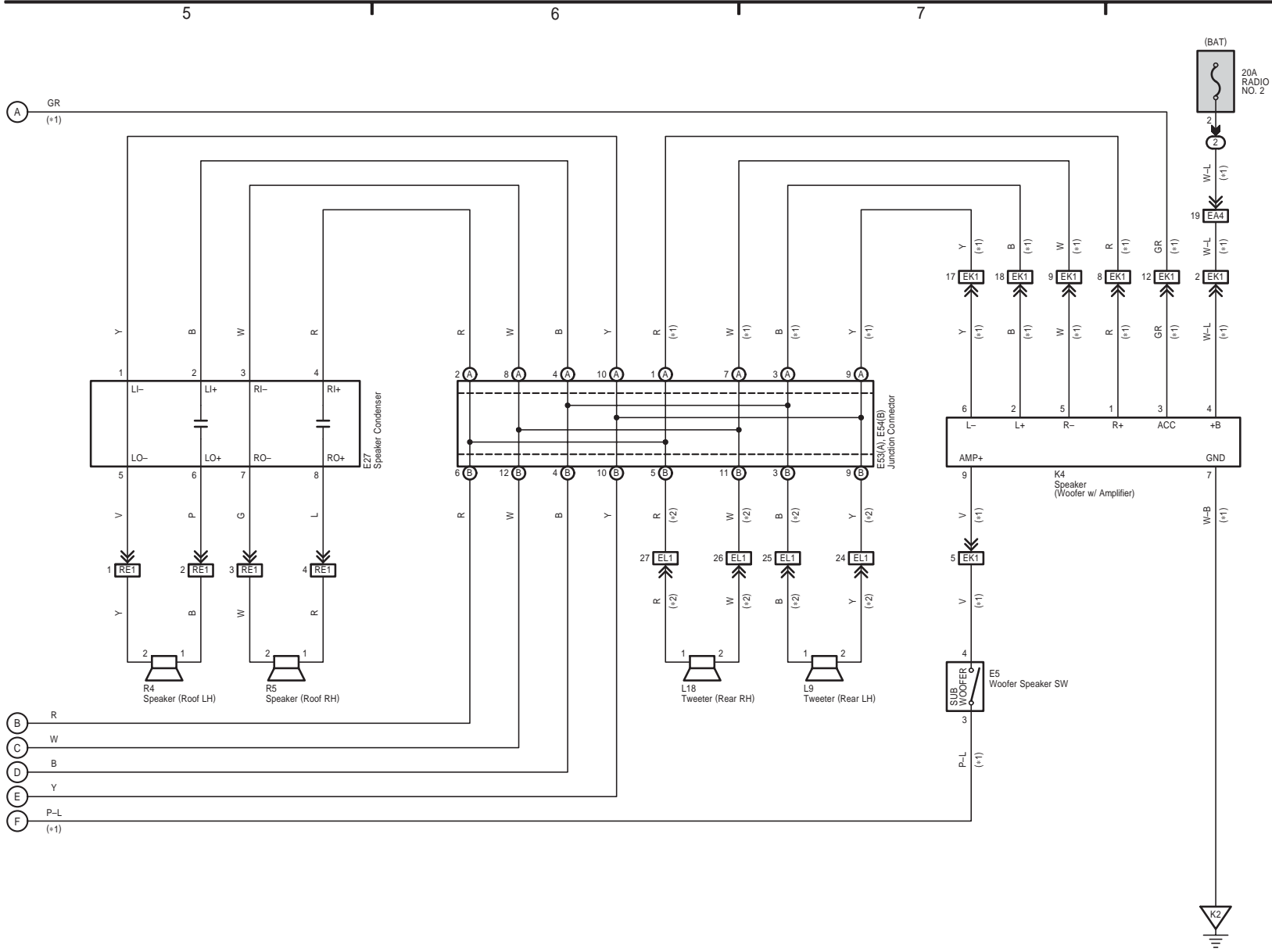

FJ CRUISER (EM0240U)



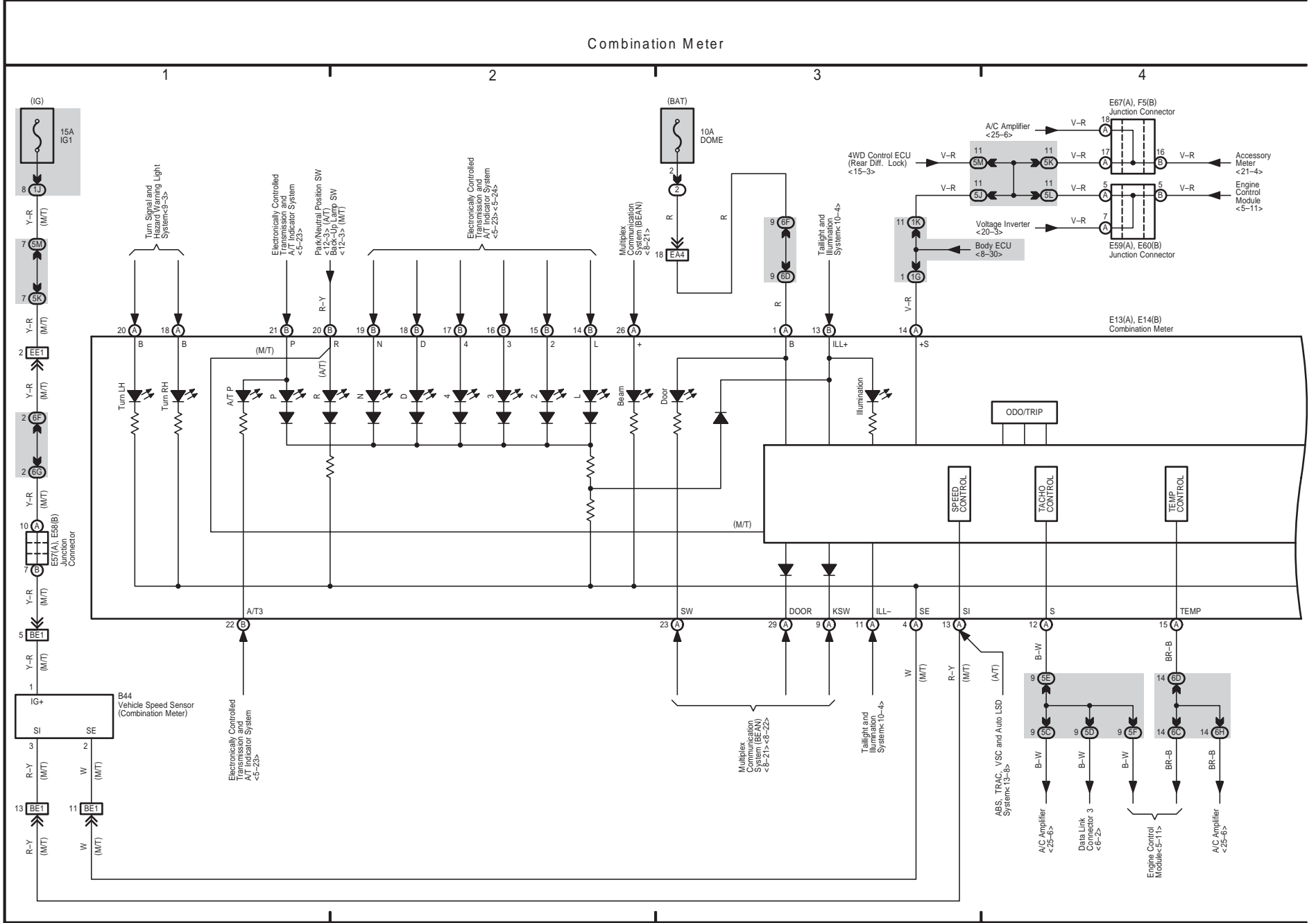

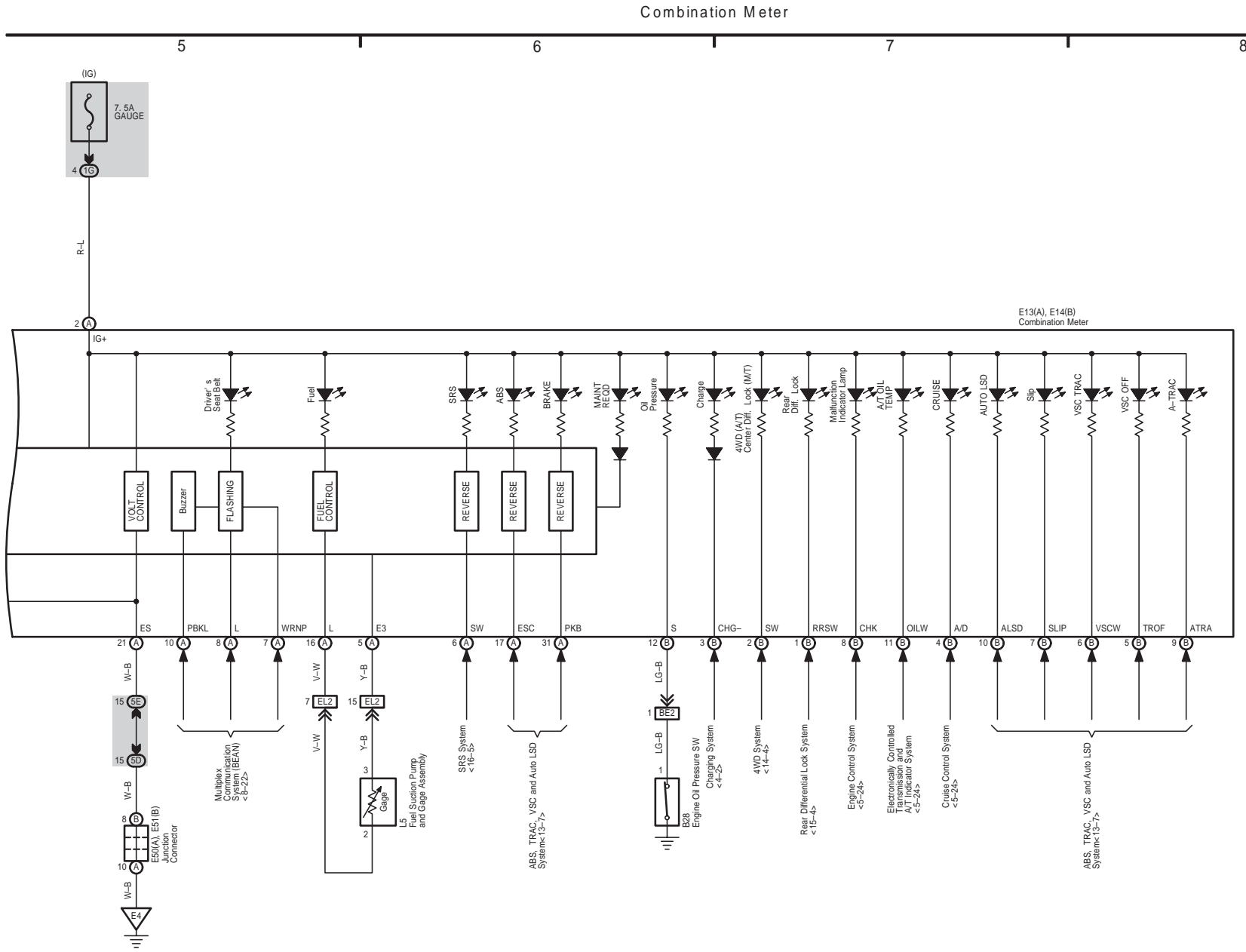

Air Conditioning

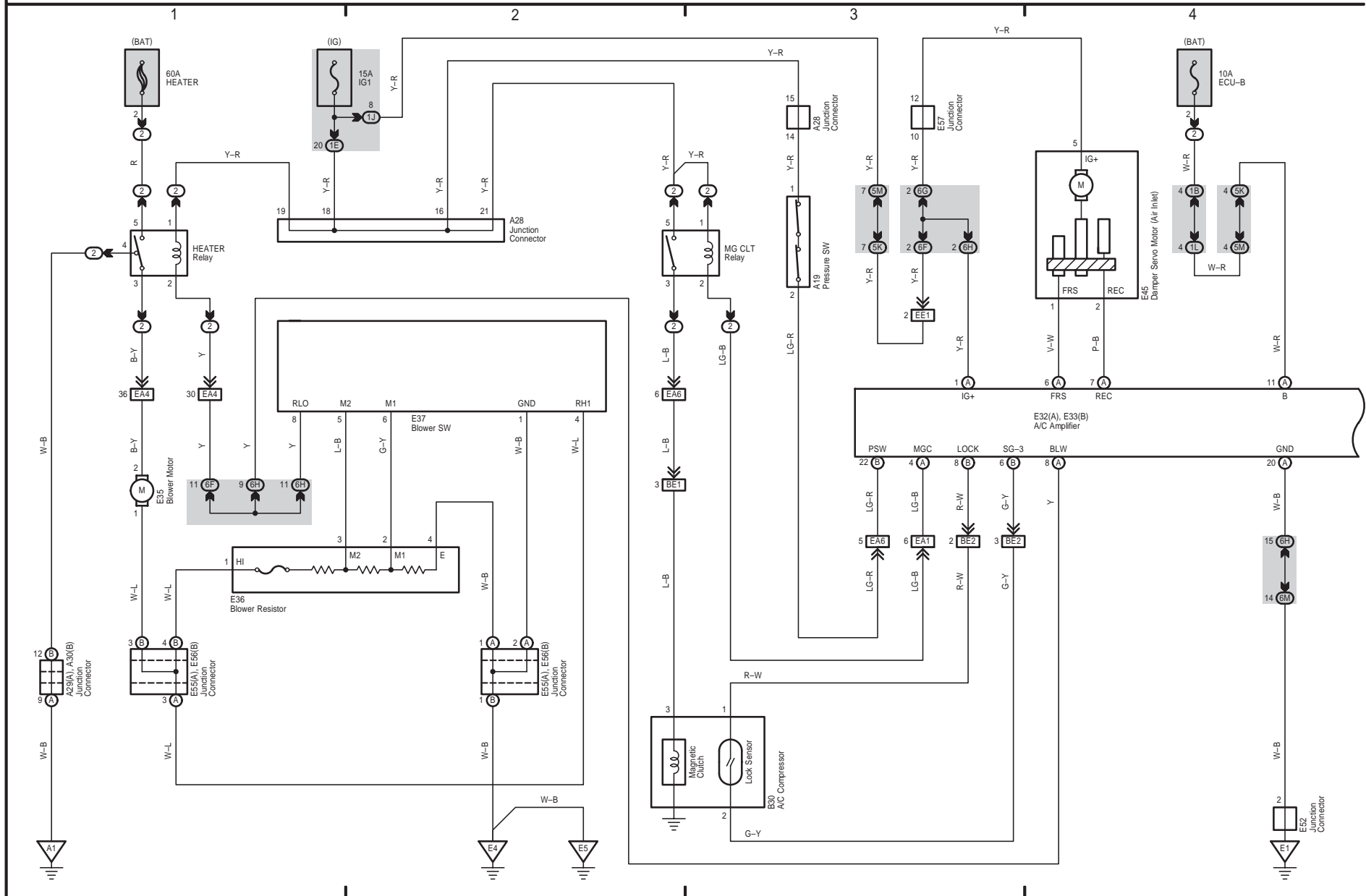

Air Conditioning

5 6 7 8

FJ CRUISER (EM0240U)

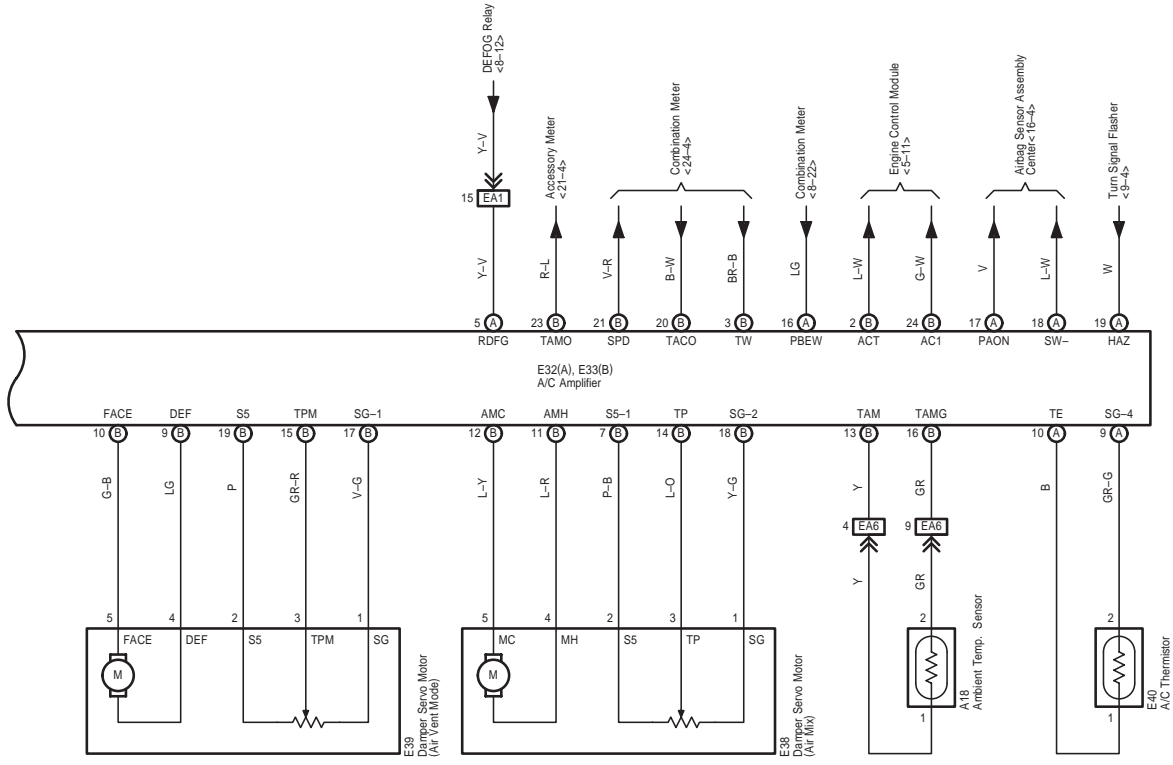

26 FJ CRUISER

