

SRS AIRBAG SYSTEM

DESCRIPTION

The SRS (Supplemental Restraint System) airbag system has the following equipment:

Item		Equipment
Frontal Collision	SRS Driver Airbag	Standard
	SRS Front Passenger Airbag	
Side/Rear Side Collision	SRS Side Airbag	Optional
	SRS Curtain Shield Airbag	
Front Passenger Occupant Classification System		Standard

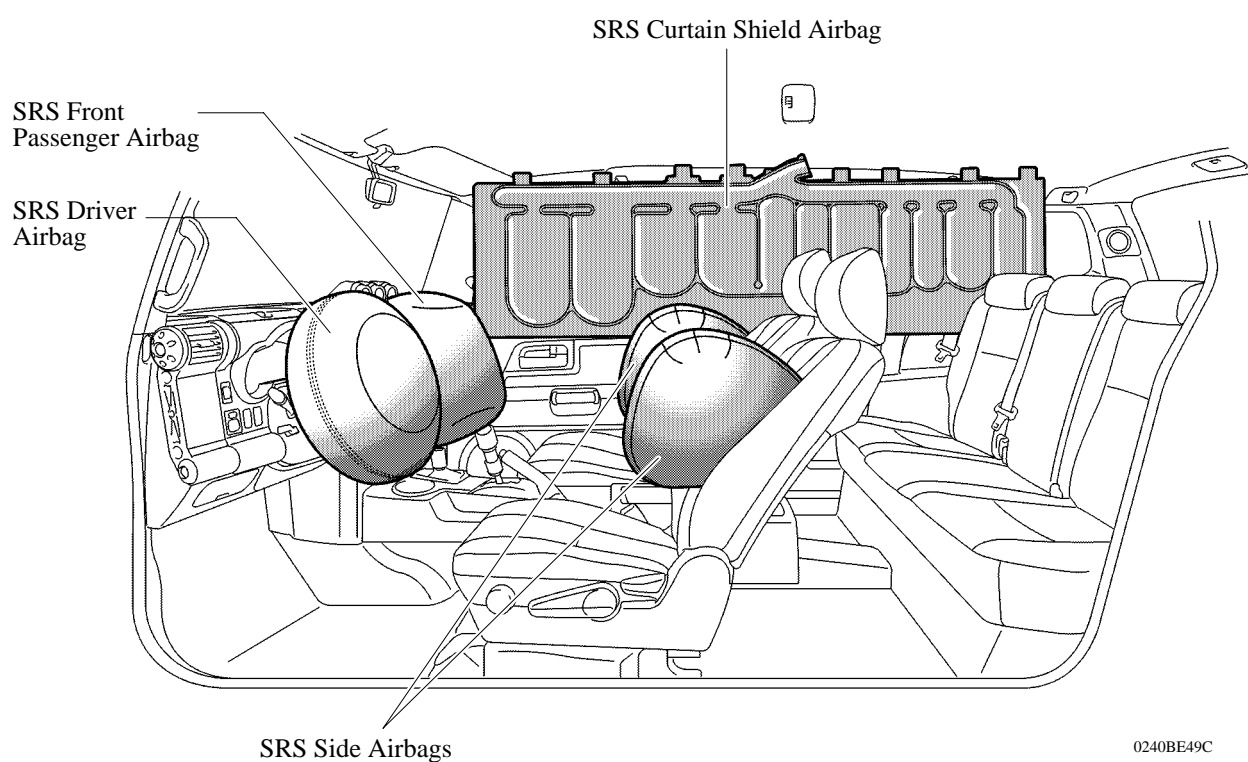

0240BE49C

- The SRS driver and front passenger airbags are used as supplements to the seat belts to help reduce shocks applied to the head and chest of the driver or front passenger in the event of a frontal impact collision.
- The SRS side airbags are used to help reduce the shocks applied to the chest of the driver or front passenger in the event of a side impact collision.
- The SRS curtain shield airbags are used to help reduce the shocks applied to the head of the driver, front passenger, or rear outer passenger in the event of side or rear side impact collision.

■ LAYOUT OF MAIN COMPONENTS

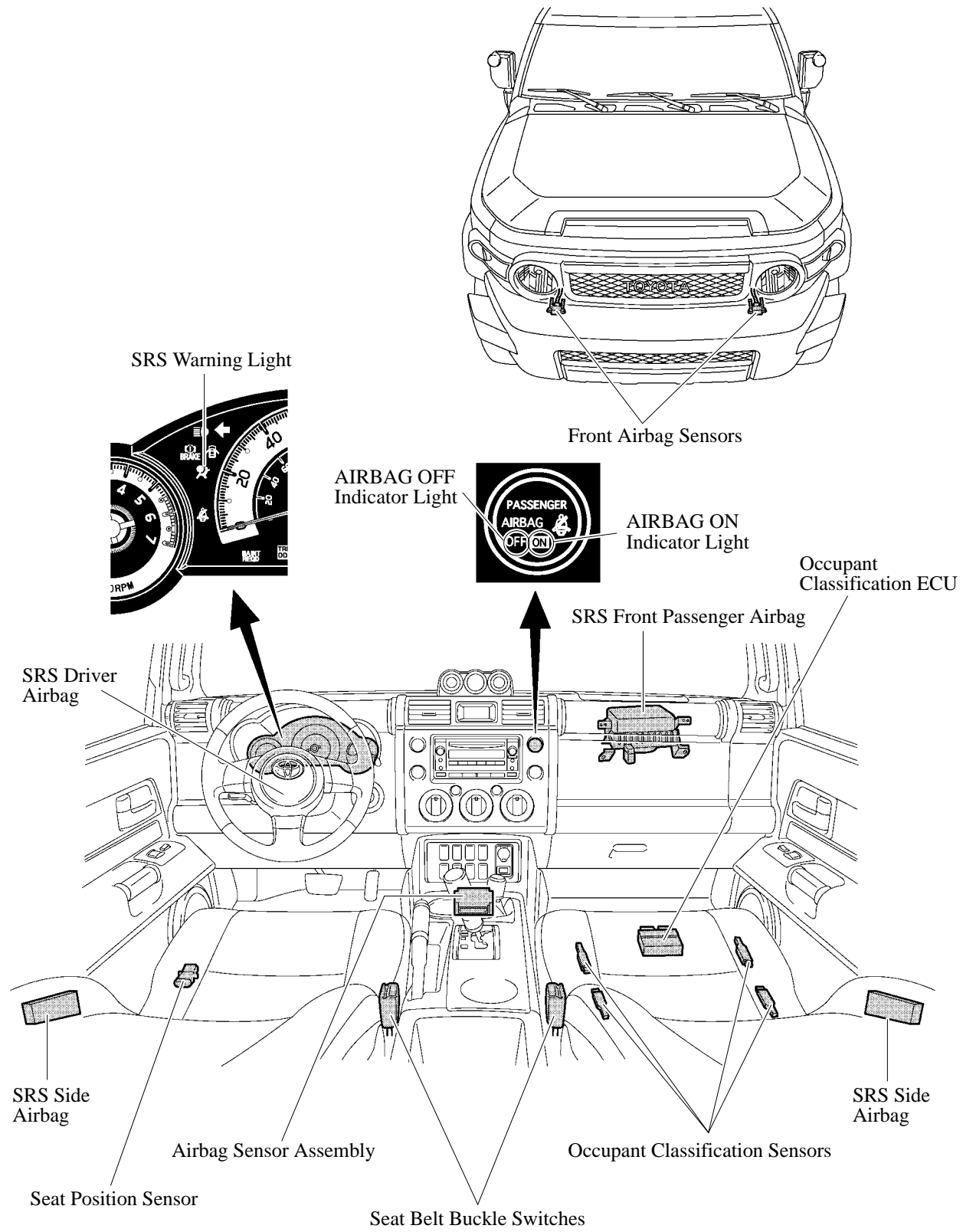

BODY ELECTRICAL — SRS AIRBAG SYSTEM

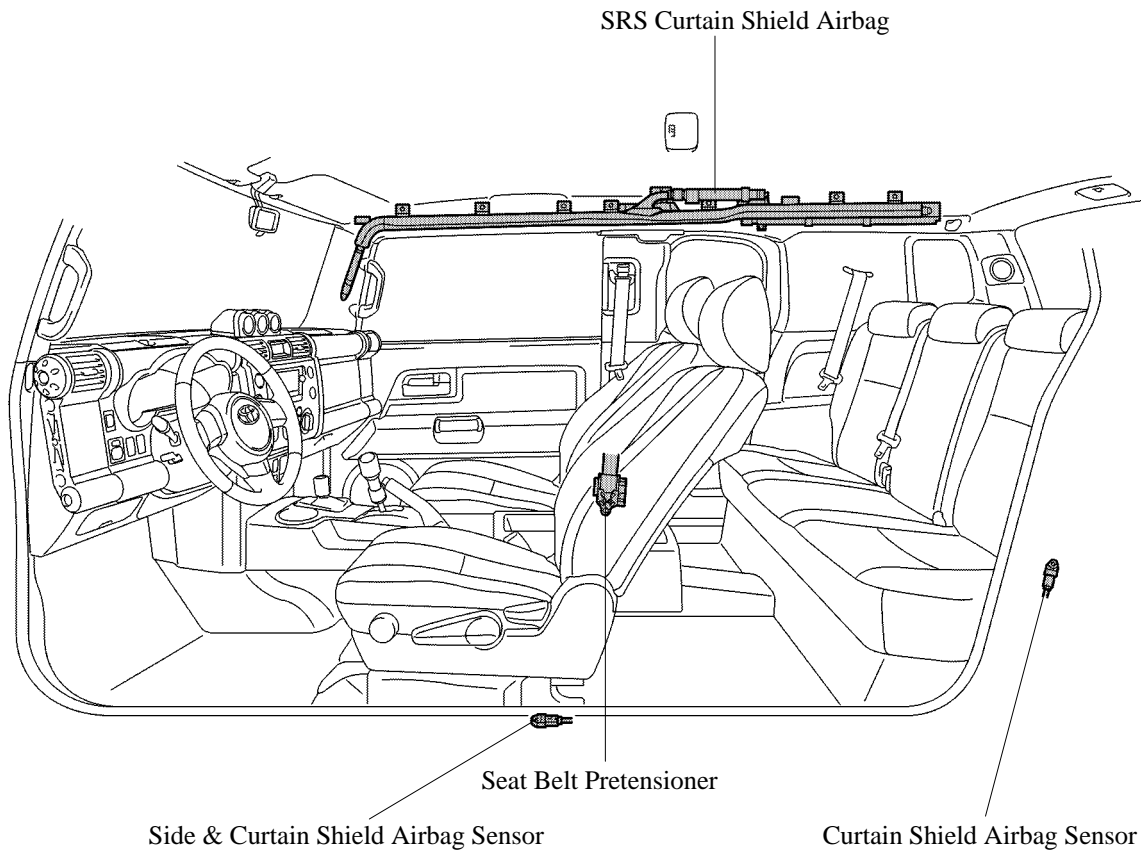

0240BE51C

■ SYSTEM DIAGRAM

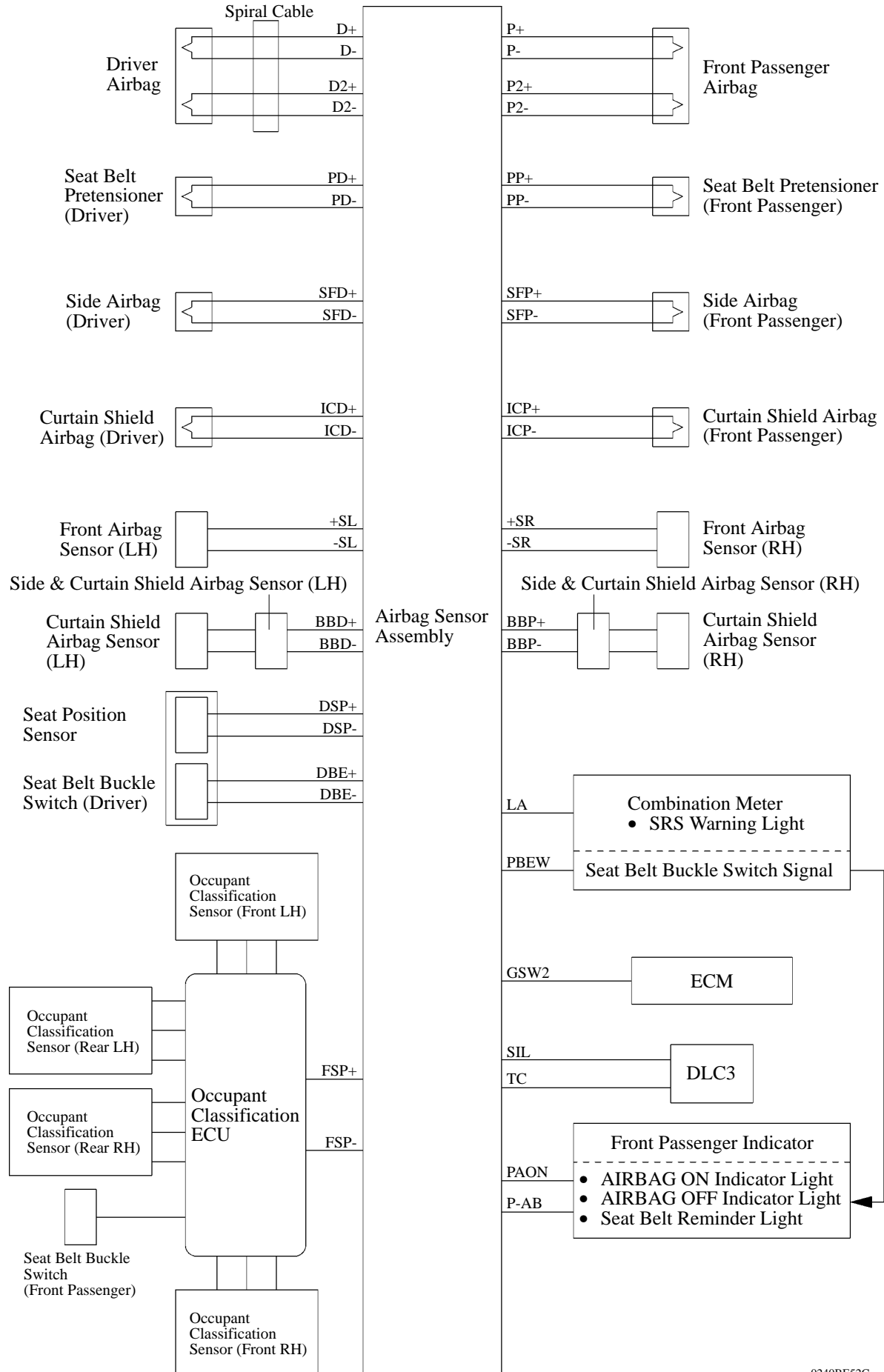

■ AIRBAG FOR FRONTAL COLLISION

1. General

There are two airbags for frontal collisions: driver and front passenger. These airbags deploy simultaneously. The SRS driver and front passenger airbags use a dual-stage control.

- Airbag Sensor Assembly detects the information indicated below from various sources in order to control the dual stage activation.

Airbag	Information	Source
Driver	Extent of Impact	<ul style="list-style-type: none"> ● Front Airbag Sensor (RH or LH) ● Airbag Sensor Assembly
	Driver Seat Position	Seat Position Sensor
	Seat Belt Condition	Seat Belt Buckle Switch (Non-contact Type)
Front Passenger	Extent of Impact	<ul style="list-style-type: none"> ● Front Airbag Sensor (RH or LH) ● Airbag Sensor Assembly
	Occupant Classification	Four Occupant Classification Sensors (Through the Occupant Classification ECU)
	Seat Belt Condition	Seat Belt Buckle Switch (Non-contact Type) (Through the Occupant Classification ECU)

► System Diagram ◀

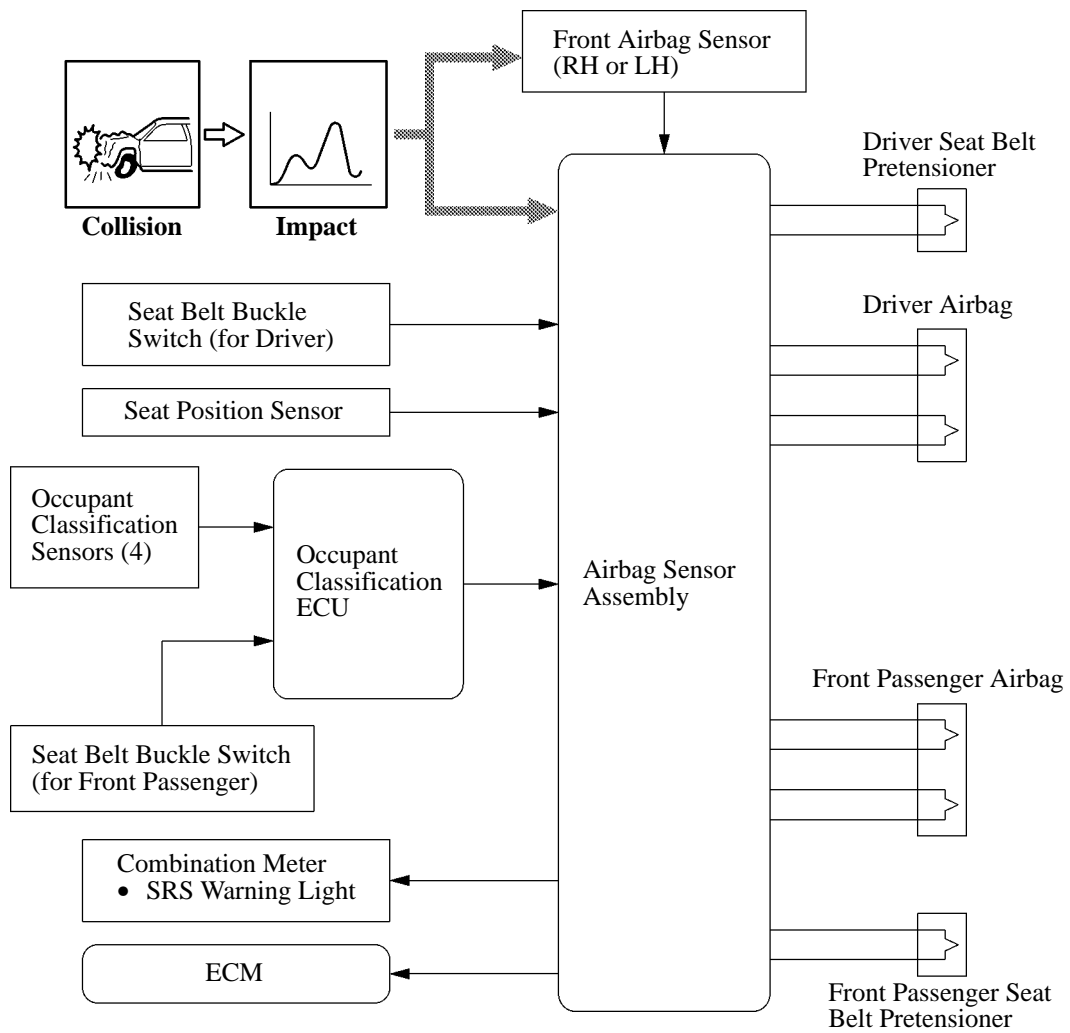

2. SRS Driver and Front Passenger Airbags

The SRS driver and front passenger airbags each contain a set of two initiators and propellants. The Airbag Sensor Assembly helps optimize the airbag inflation output by controlling the inflation timing of these initiators.

3. Front Airbag Sensor

Front airbag sensor contains an electrical type deceleration sensor. Based on the deceleration of the vehicle during a front collision, a distortion is created in the sensor and converted into an electrical signal. Accordingly, the extent of the collision can be detected in detail.

4. Seat Belt Buckle Switch

The seat belt buckle switch detects if the seat belt is fastened.

- A contact type and non-contact type switch is built in to the seat belt buckle on the driver side. The contact type switch is for the seat belt reminder system and the non-contact type switch is for the SRS airbag system.
- A non-contact type switch is built in to the seat belt buckle on the front passenger side.
- The non-contact type switch contains a Hall IC and two magnets, installed into the front seat inner belt assembly.

► Electrical Circuit ◀

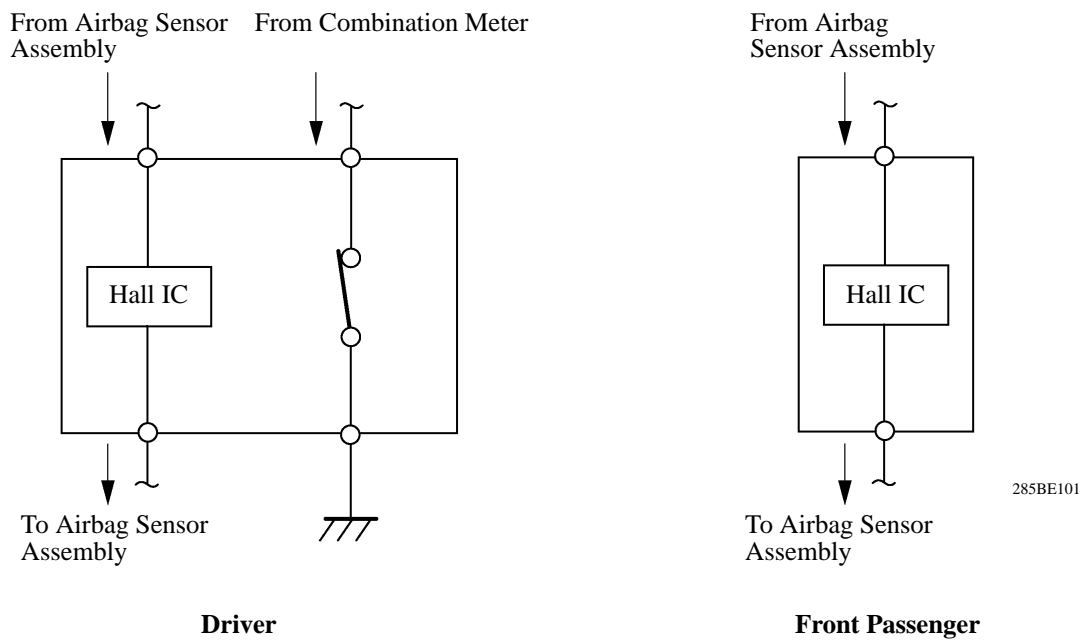

BODY ELECTRICAL — SRS AIRBAG SYSTEM

- The ejector inside the front seat inner belt assembly and the plate installed to the ejector move when the seat belt is removed or applied. The movement of the plate creates the magnetic flux density of the magnet.
- The Hall IC detects the changes in the magnetic flux density as seat belt removal or application, and outputs the signal to Airbag Sensor Assembly.

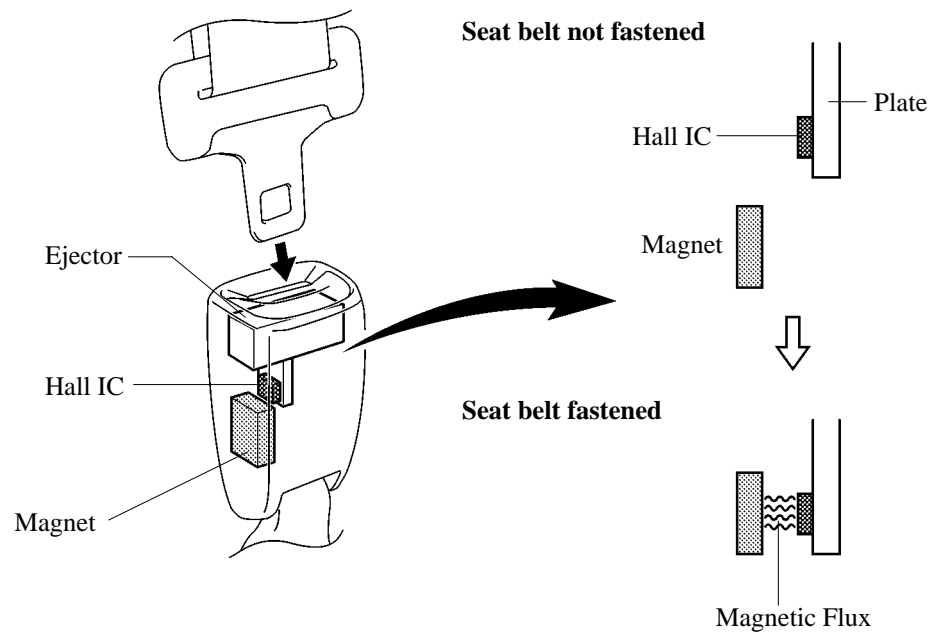

285BE143

5. Seat Position Sensor

- The seat position sensor, which is attached to the seat rail of the driver seat, detects the sliding position of the seat. In addition, the shielding plate to make the seat position sensor judge the seat position is installed on this seat rail.
- The seat position sensor use a Hall IC for its sensor and has magnet portion on its opposite side.

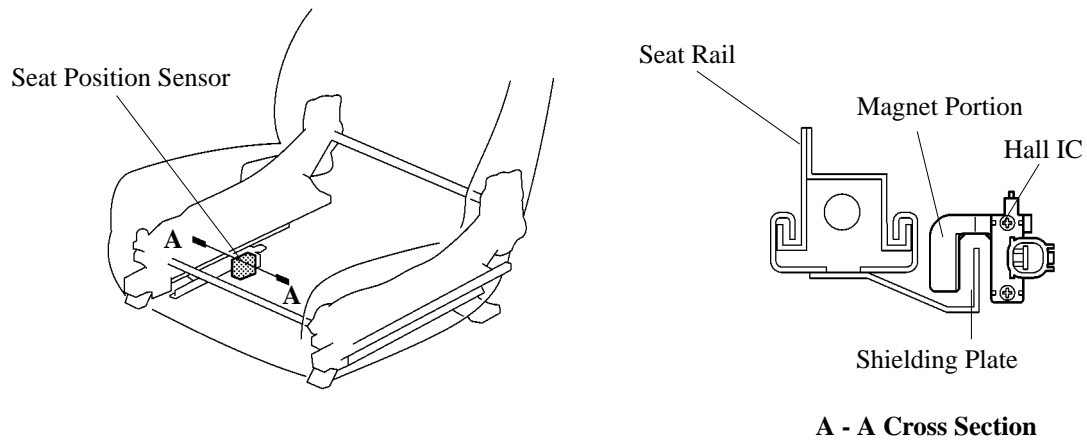

232BE47

- The seat position detection by the seat position sensor judges that the seat position is rearward if the shielding plate is between the sensor and the seat position is forward if the shielding plate is not between the sensor.

► **Seat position is rearward** ◀

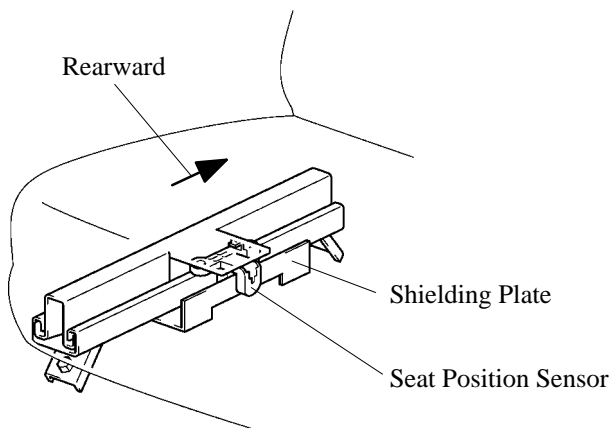

230LX91

► **Seat position is forward** ◀

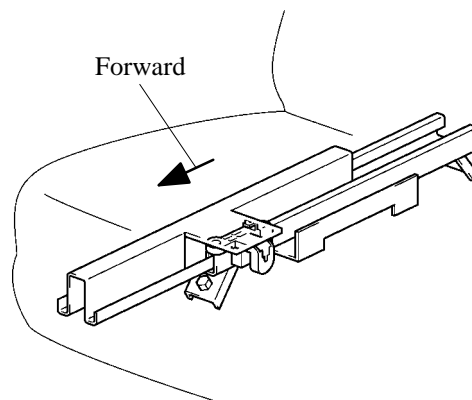

230LX92

■ AIRBAG FOR SIDE/REAR SIDE COLLISION

1. General

- When the side & curtain shield airbag sensor detects a side impact, the Airbag Sensor Assembly causes the side curtain shield airbag and the side airbag to be deployed simultaneously.
- When the curtain shield airbag sensor detects a rear side impact, the Airbag Sensor Assembly causes the curtain shield airbag to be deployed.

► System Operation ◀

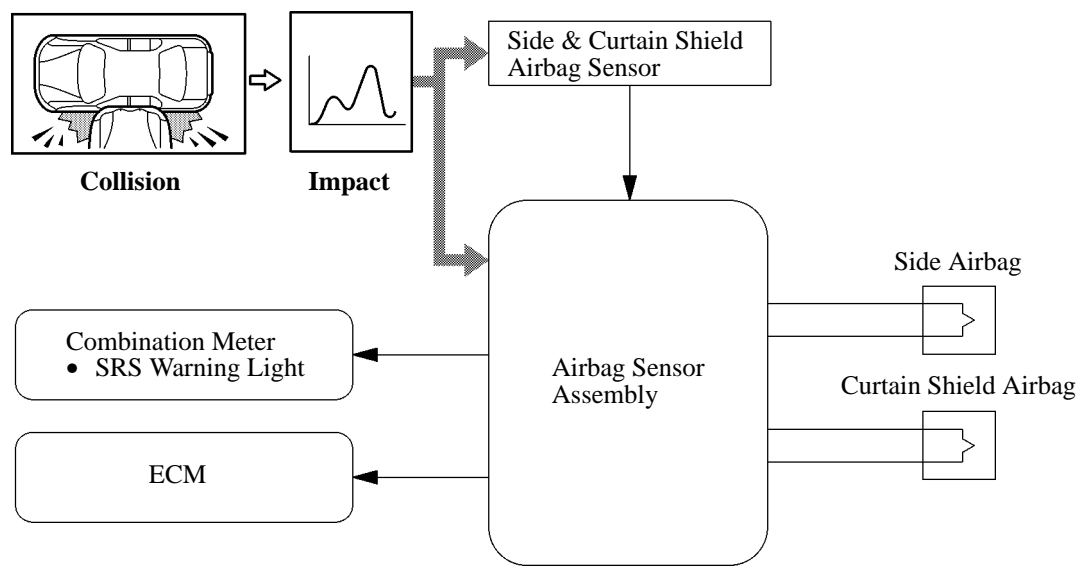

0240BE55C

Airbag for Side Collision

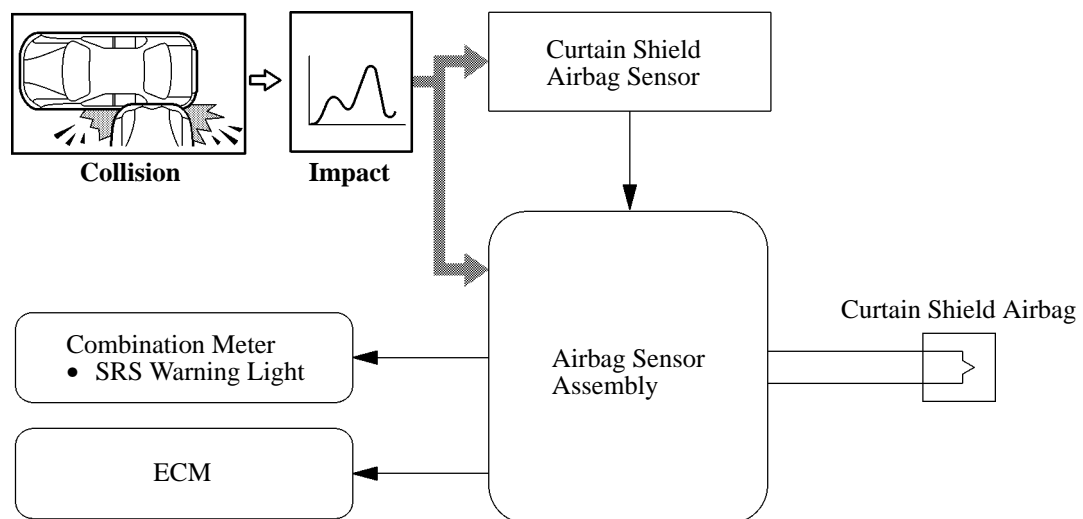

0240BE62C

Airbag for Rear Side Collision

2. SRS Side Airbag

SRS side airbags are installed in the seat backs of the driver seat and the front passenger seat. Each SRS airbag is a one-piece design, consisting of an inflator, a bag, and a cover.

3. SRS Curtain Shield Airbag

SRS curtain shield airbags are installed in the area close to the sides of the headliner. Each SRS airbag is a one-piece design, consisting of an inflator, a bag, and a cover.

4. Side & Curtain Shield and Curtain Shield Airbag Sensors

Deceleration sensors are enclosed in the side & curtain shield or curtain shield airbag sensors. Based on the acceleration of the vehicle during a side or side rear collision, a distortion is created in the sensor and converted into an electrical signal.

■ FRONT PASSENGER OCCUPANT CLASSIFICATION SYSTEM

1. General

The front passenger occupant classification system judges whether the front passenger seat is occupied by an adult or child (with child seat) or is unoccupied, in accordance with the load that is applied to the front passenger seat and whether the seat belt is buckled. Thus, it restricts the deployment of the front passenger airbag, front passenger side airbag, and the front passenger seat belt pretensioner. In addition, the system informs the driver of the result of the judgment through the use of the AIRBAG ON/OFF indicator lights.

- This system consists of the Occupant Classification ECU, four occupant classification sensors, “AIRBAG ON/OFF indicator lights”, seat belt buckle switch, and Airbag Sensor Assembly.

► System Diagram ◀

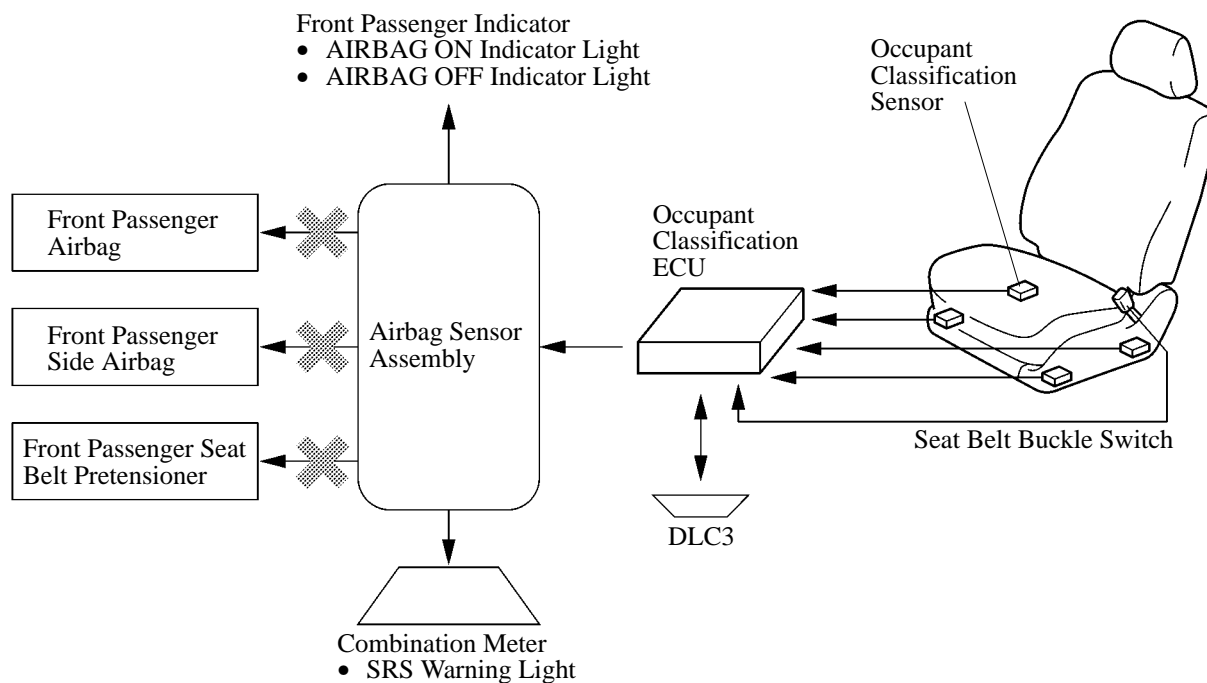

267NF12

Service Tip

- When installing items to the front passenger seat or removing/installing the front passenger seat, connect the hand-held tester, perform a system check and perform a zero-point calibration of the sensor load value.
- If performing maintenance due to the SRS warning light being on constantly or due to a collision, in addition to the above item, check that the hand-held tester display value indicates within the range of 30 kg (66 lb) +/- 3 kg (6.6 lb) when a 30 kg (66 lb) weight is placed on the front passenger seat. For details, see the 2007 FJ Cruiser Repair Manual (Pub. No. RM0240U).

2. Wiring Diagram

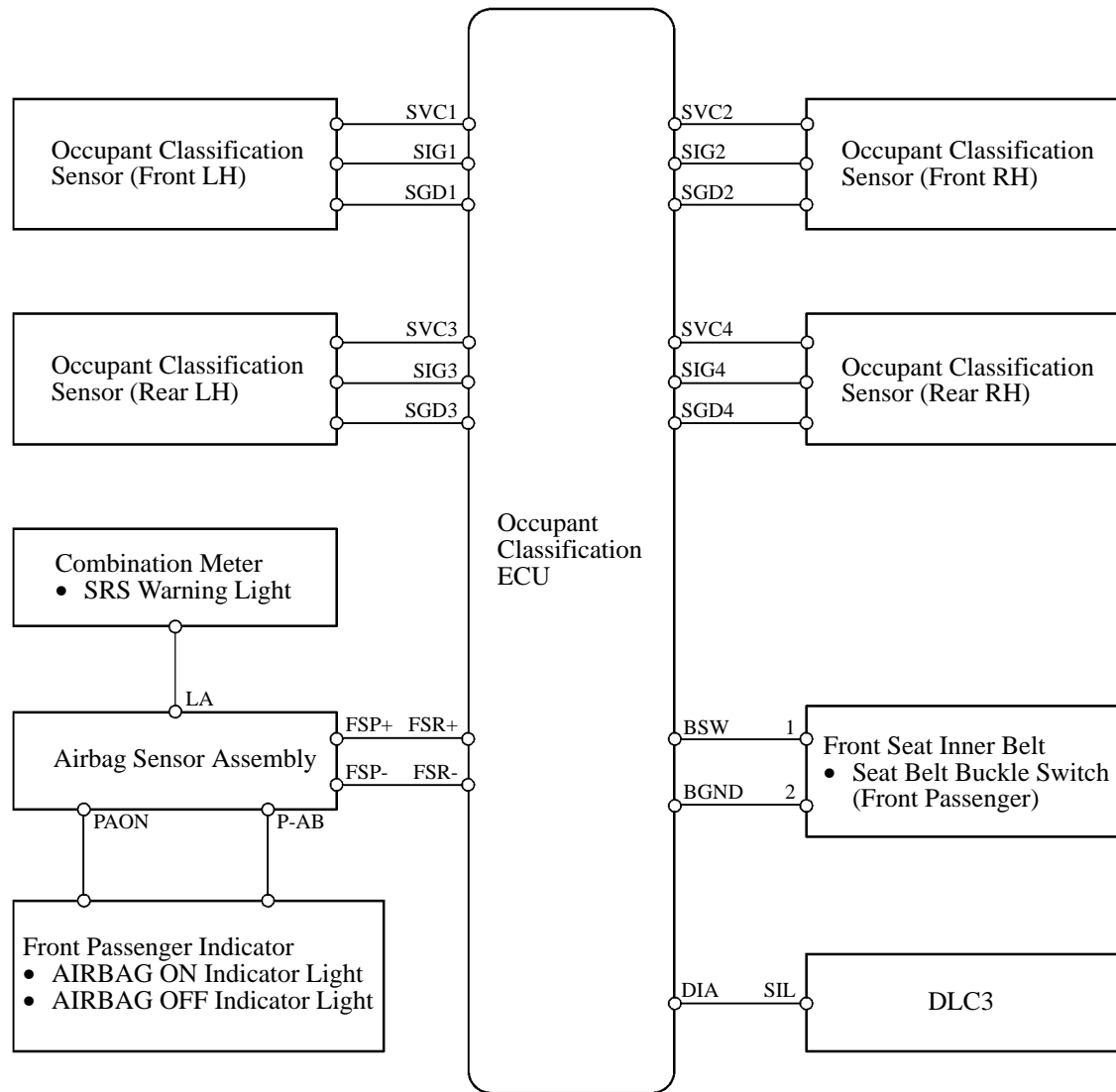

3. Occupant Classification Sensors

The occupant classification sensors are installed on four brackets connecting the seat rail and the seat frame. The resistance values of these sensors, which vary in accordance with the distortion that acts on the brackets, are output to the Occupant Classification ECU.

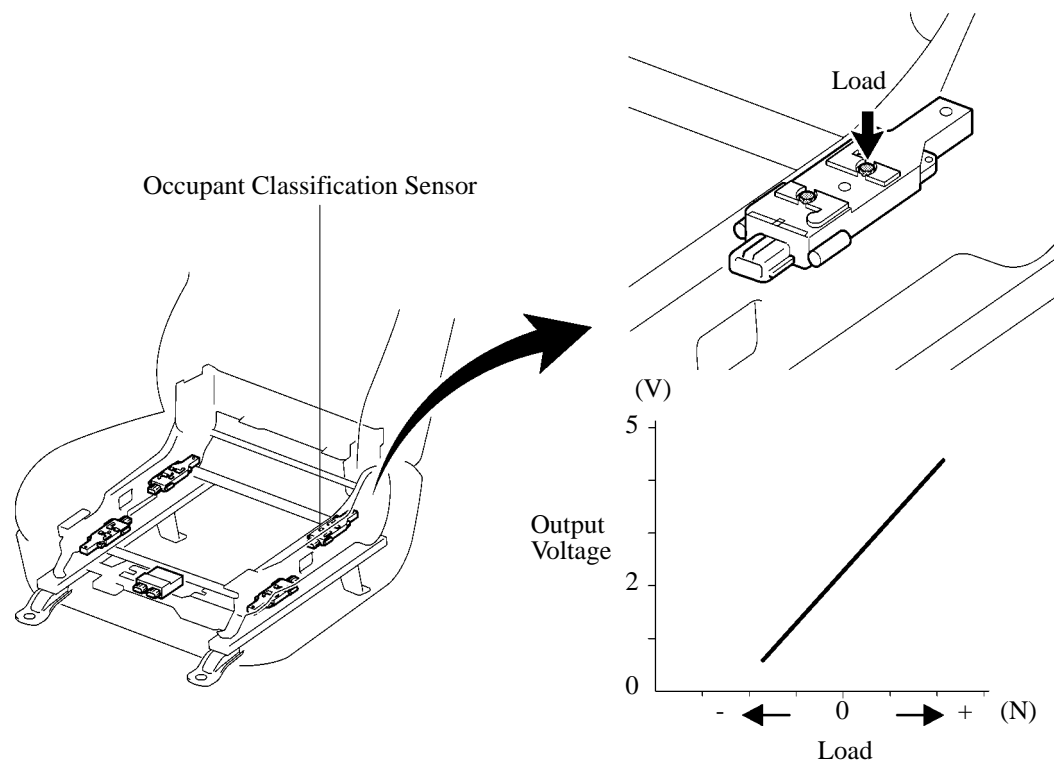

4. System Operation

General

This system makes the following judgments: unoccupied judgment, child seat judgment, child judgment, and adult judgment. In addition, it performs an initial check to check the circuit of the AIRBAG ON/OFF indicator lights when the ignition switch is ON.

- The Occupant Classification ECU constantly monitors the weight on the front passenger seat, and makes a judgment in accordance with the signals from the occupant classification sensor and the state of the seat belt buckle switch, regardless of the position of the ignition switch.
- The Occupant Classification ECU contains criteria value “A” to judge whether the seat is being occupied by a child or a child seat in accordance with the signals from the four occupant classification sensors and seat belt buckle switch, and criteria value “B” to judge whether the occupant is an adult or child (with child seat).
- The Occupant Classification ECU makes an occupied or unoccupied judgment in accordance with the signals from the seat belt buckle switch.

Unoccupied Judgment

- The Occupant Classification ECU makes an unoccupied judgment when the judgment value is lower than criteria value “A” and the seat belt buckle switch is OFF.
- If the ignition switch is turned ON in this state, the system performs an initial check, and does not illuminate the AIRBAG ON/OFF indicator lights. Then, the system prohibits the deployment of the front passenger airbag, front passenger side airbag, and the front passenger seat belt pretensioner, and does not blink the seat belt reminder light.

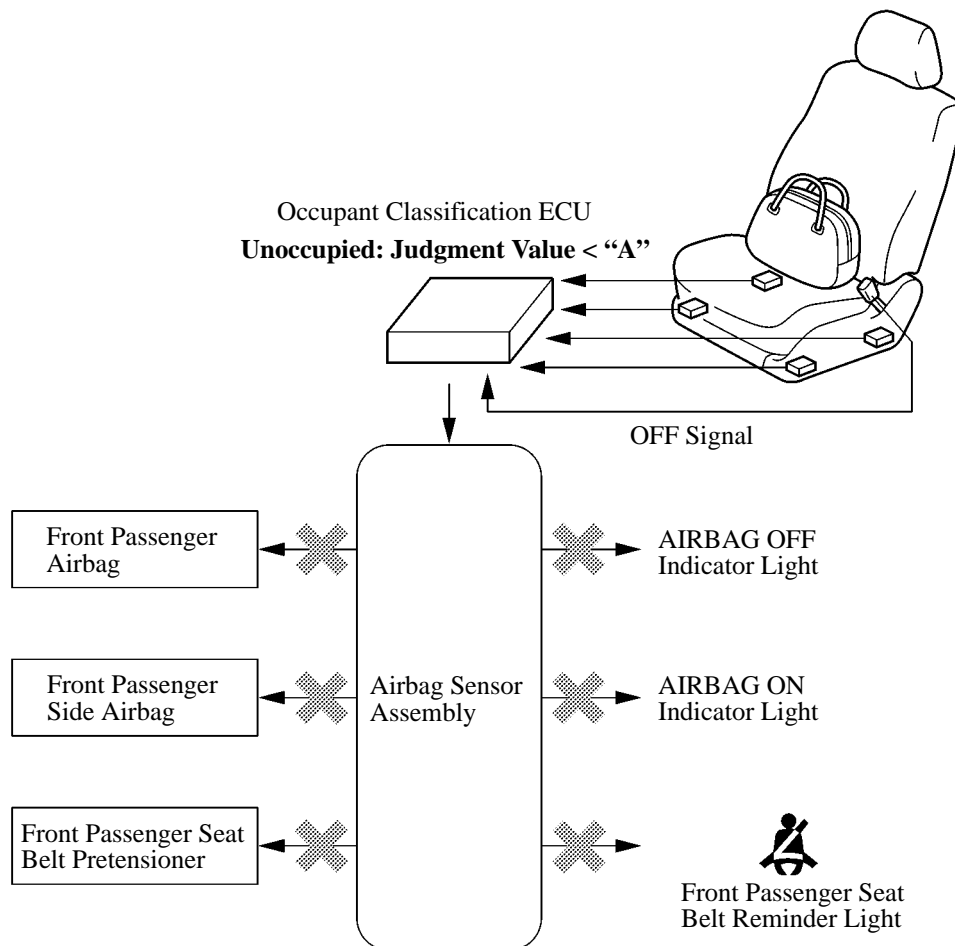

Child Seat or Child Judgment

- If the judgment value is lower than criteria value “B” and the seat belt buckle switch is ON, the Occupant Classification ECU judges that a child seat is installed.
- If the judgment value is higher than criteria value “A”, but lower than criteria value “B”, and the seat belt buckle switch is OFF, the Occupant Classification ECU judges that the seat is being occupied by a child.
- When the ignition switch is turned ON under these conditions, the system performs an initial check and illuminates the AIRBAG OFF indicator light to indicate that the front passenger airbag and the front passenger side airbag have been deactivated.

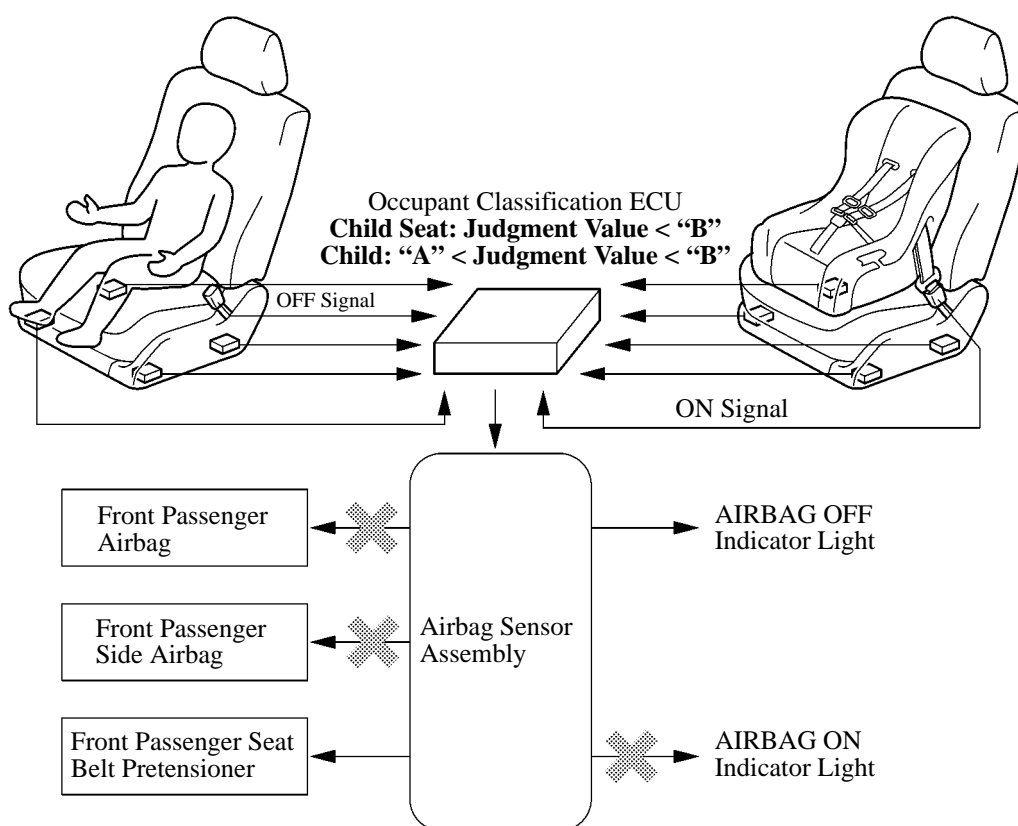

D13N56

- After the Occupant Classification ECU judges that a child seat is installed, the AIRBAG OFF indicator light does not go off unless the seat belt buckle switch is turned OFF.

Adult Judgment

- When the judgment value is higher than criteria value “B”, the Occupant Classification ECU judges that the seat is being occupied by an adult.
- If the ignition switch is turned ON in this state, the system performs an initial check and illuminates the AIRBAG ON indicator light, indicating that the front passenger airbag and the front passenger side airbag are active.

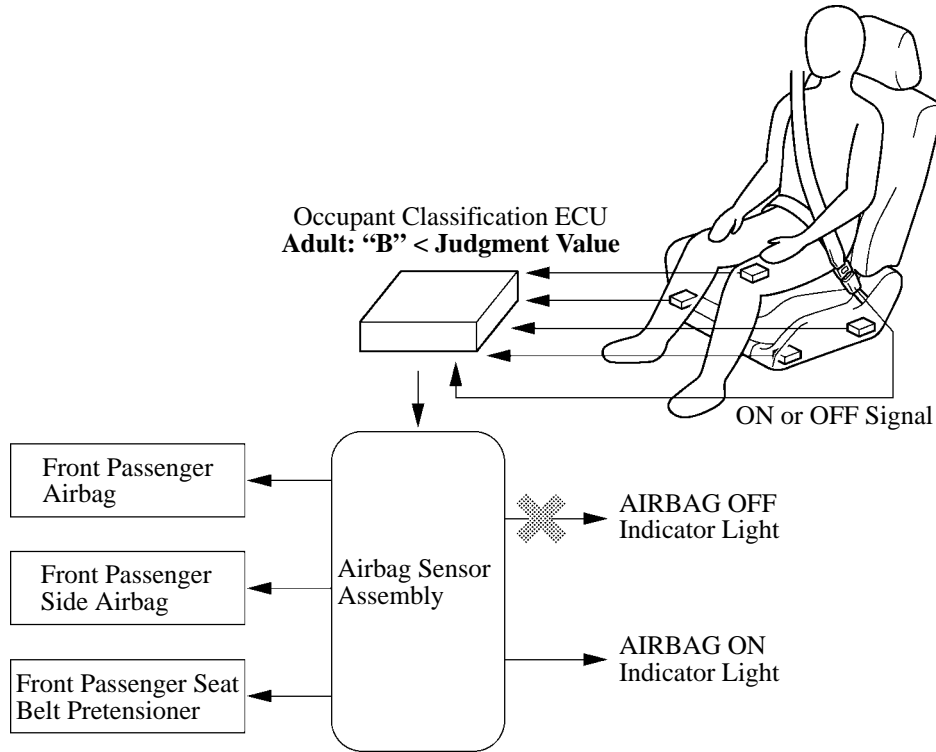

D13N57

- After the Occupant Classification ECU judges that the occupant is an adult, and if the judgment value is determined as criteria value “B” or less according to occupant load movement, the ECU continues adult judgment for approximately ten seconds before switching the child judgment.

Initial Check

After the ignition switch is turned ON, the Occupant Classification ECU lights up the AIRBAG ON/OFF indicator lights via Airbag Sensor Assembly based on the timing chart below in order to check the indicator light circuits.

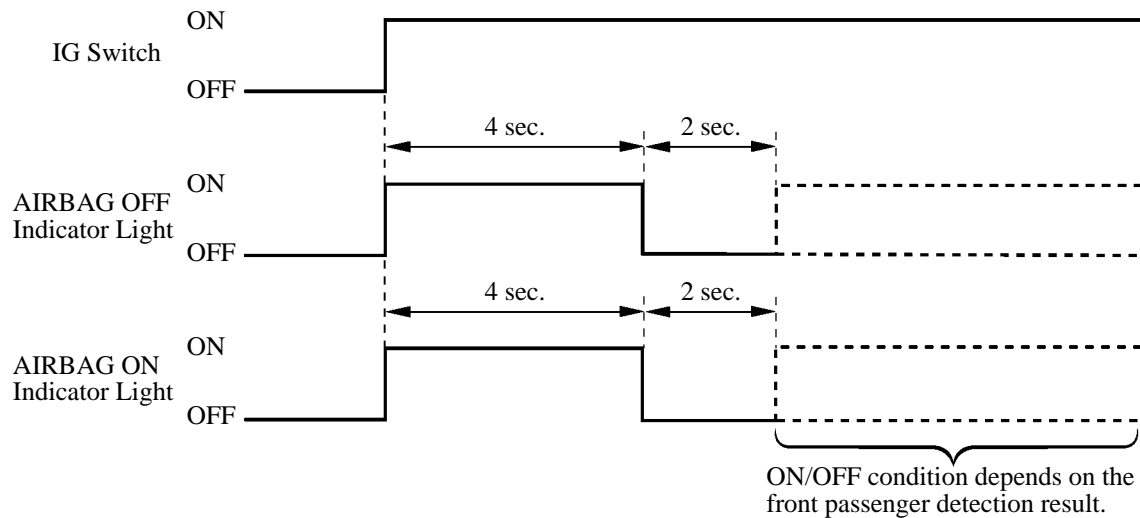

259ESW53

5. Precautions for Front Passenger Occupant Classification System Operation

To avoid potential death or serious injury when the front passenger occupant classification system does not detect the conditions correctly, observe the following.

- Wear the seat belt properly.
- Make sure that the front passenger's seat belt tab is not inserted into the buckle before someone sits in the front passenger seat.
- Make sure the AIRBAG ON indicator light is illuminated when using a seat belt extender for the front passenger seat. If the AIRBAG OFF indicator light is illuminated, disconnect the extender tongue from the seat belt buckle, then reconnect the seat belt. Reconnect the seat belt extender after making sure the AIRBAG ON indicator light is illuminated. If you use the seat belt extender while the AIRBAG OFF indicator light is illuminated, the front passenger airbag and side airbag on the front passenger side may not activate correctly, which could cause death or serious injury in the event of collision (the seatbelt extender always needs to be connected to the seat mounted buckle after the occupant sits in the seat).
- Do not put a heavy load in the front passenger seatback pocket or attach a seatback table to the front passenger seat seatback.
- Do not put weight on the front passenger seat by putting your hands or feet on the front passenger seat seatback from the rear passenger seat.
- Do not let a rear passenger lift the front passenger seat with their feet or press on the seatback with their legs.
- Do not put objects under the front passenger seat.
- Do not recline the front passenger seat seatback so far that it touches a rear seat. This may cause the AIRBAG OFF indicator light to be illuminated, which indicates that the passenger's airbags will not deploy in the event of a severe accident. If the seatback touches the rear seat, return the seatback to a position where it does not touch the rear seat.
Keep the front passenger seatback as upright as possible when the vehicle is moving. Reclining the seatback excessively may lessen the effectiveness of the seat belt system.
- Make sure the AIRBAG ON indicator light may be illuminated when an adult sits in the front passenger seat. If the AIRBAG OFF indicator light is illuminated, ask the passenger to sit properly with back upright and against the seat, with legs comfortably extended and wear the seat belt correctly. Nonetheless, if the AIRBAG OFF indicator light remains illuminated, let the passenger sit in the rear seat. When it is unavoidable to sit in the front passenger seat, ask the passenger to move the seat as far back as possible, remain properly seated.
- When installation of a forward facing child restraint system on the front seat is unavoidable, install the child restraint system on the front passenger seat in the proper order.
- Do not kick the front passenger seat or subject it to severe impact. Otherwise, the SRS warning light may come on to indicate a malfunction of the detection system.
- Child restraint systems installed on the rear seat should not contact the front seatbacks.

■ IMPROPER CONNECTION PREVENTION LOCK MECHANISM

An improper connection prevention lock mechanism consists of Airbag Sensor Assembly and the holder.

- Airbag Sensor Assembly has an axis.
- The holder has a lever. The holder and the connectors are locked via a retainer and a lance.

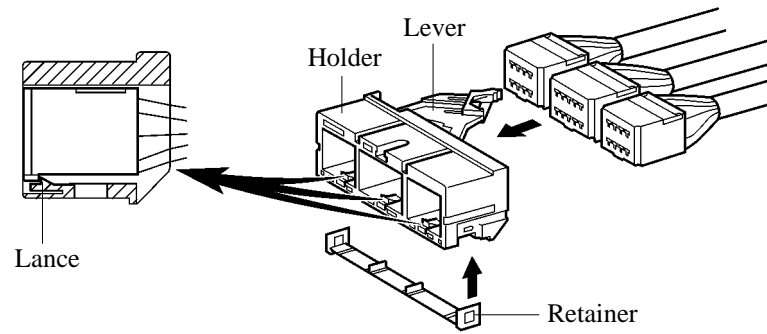

264BE45

When connecting the holder with connector, the lever is pushed into the locked position by rotating it around the pin axis in order to lock the holder securely.

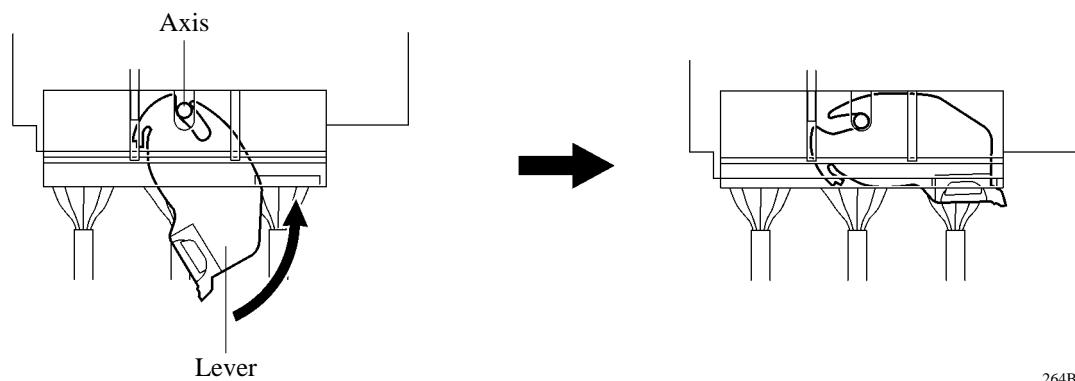

264BE46

■ **EDR (EVENT DATA RECORDER)**

Airbag Sensor Assembly that monitor and control certain aspects of vehicle.

These computers assist in driving and maintaining optimal vehicle performance.

This is called an Event Data Recorder (EDR).

The Airbag Sensor Assembly contains the EDR.

In a crash or a near car crash event, this device may record some or all of the following information:

- Whether the driver and front passenger wore the seat belts or not
- Driver's seat position
- SRS airbag deployment data
- SRS airbag system diagnostic data

The information above is intended to be used for the purpose of improving vehicle safety performance.

Unlike general data recorders, the EDR does not record sound data such as conversation between passengers.

Toyota will not disclose the data recorded in an EDR to a third party except when:

- An agreement from the vehicle's owner (or the leasing company for a leased vehicle) is obtained
- Officially requested by the police or other authorities
- Used as a defense for Toyota in a law suit
- Ordered by the court

However, if necessary Toyota will:

- Use the data for research on Toyota vehicle safety performance
- Disclose the data to a third party for research purposes without disclosing details of the vehicle owner, and only when it is deemed necessary
- Disclose summarized data cleared of vehicle identification information to a non. Toyota organization for research purposes

■ DIAGNOSIS

1. General

If Airbag Sensor Assembly detects a malfunction in the SRS airbag system, Airbag Sensor Assembly stores the malfunction data in memory, in addition to illuminating the SRS warning light.

- Airbag Sensor Assembly outputs malfunction data, 5-digit DTCs (Diagnostic Trouble Codes) or 2-digit DTCs, to the hand-held tester or the SRS warning light.

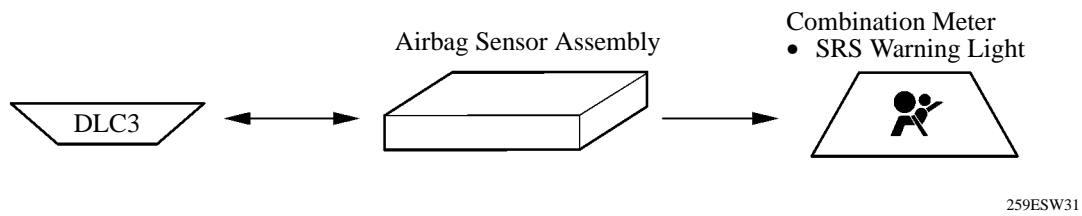

If the Occupant Classification ECU detects a malfunction in the front passenger occupant classification system, the Occupant Classification ECU stores the malfunction data in memory. If the Airbag Sensor Assembly detects a malfunction in the Occupant Classification ECU, the Airbag Sensor Assembly illuminates the SRS warning light and AIRBAG OFF indicator light.

- The Occupant Classification ECU outputs 5-digit DTCs to the hand-held tester.

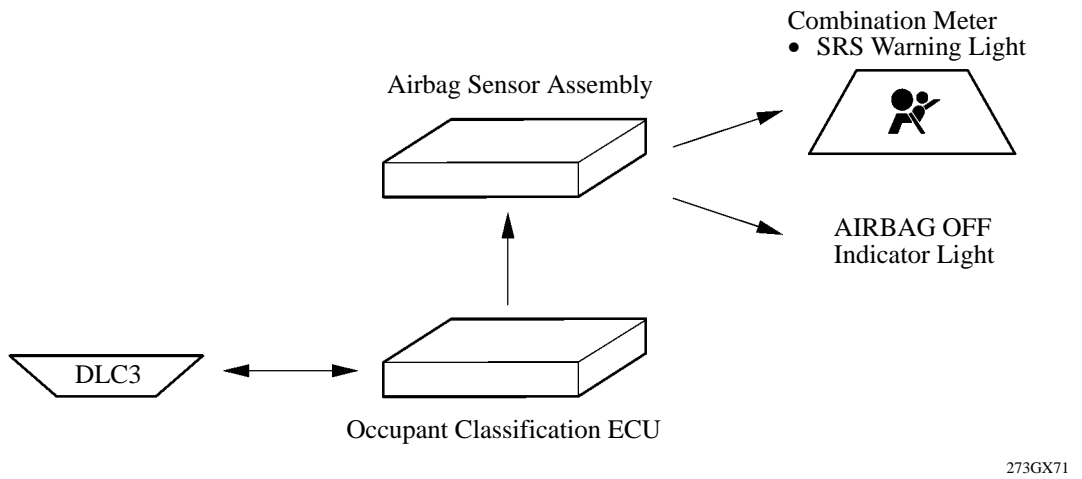

2. SRS Airbag System DTCs

There are 2 types of DTCs for the SRS airbag system: 5-digit and 2-digit DTCs.

- The 5-digit DTCs can be read after connecting a hand-held tester to the DLC3.
- The 2-digit DTCs can be read by connecting the SST (09843-18040) to the Tc and CG terminals of the DLC3 and reading the blinking of the SRS warning light.
- If the SRS airbag deploys, Airbag Sensor Assembly will turn ON the SRS warning light. However, different from the ordinary diagnosis function, a DTC will not be memorized. The SRS warning light cannot be turned OFF. It is necessary to replace the Airbag Sensor Assembly with a new one.

Service Tip

When using a hand-held tester, a dedicated adapter [CAN VIM (Vehicle Interface Module)] must be connected between the DLC3 and the hand-held tester. For details, see the 2007 FJ Cruiser Repair Manual (Pub. No. RM0240U).

3. Front Passenger Occupant Classification System DTCs

There are only 5-digit DTCs for the front passenger occupant classification system.

- The 5-digit DTCs can be read after connecting a hand-held tester to the DLC3.

For details, see the 2007 FJ Cruiser Repair Manual (Pub. No. RM0240U).

Service Tip

When using a hand-held tester, a dedicated adapter [CAN VIM (Vehicle Interface Module)] must be connected between the DLC3 and the hand-held tester. For details, see the 2007 FJ Cruiser Repair Manual (Pub. No. RM0240U).